

**MULTI/TECH**  
 ENGINEERING SERVICES, INC.  
 1155 13TH ST. S.E. SALEM, OR. 97302  
 PH. (503) 363 - 9227 FAX (503) 364-1260  
 www.mtengineering.net office@mtengineering.net

**SANITARY SEWER PLAN**

**COBURN APARTMENTS**

NO CHANGES, MODIFICATIONS OR REPRODUCTIONS TO BE MADE TO THESE DRAWINGS WITHOUT WRITTEN AUTHORIZATION FROM THE DESIGN ENGINEER.  
 DIMENSIONS & NOTES TAKE PRECEDENCE OVER GRAPHICAL REPRESENTATION.

Design:	M.D.G.
Drawn:	T.N.S.
Checked:	J.J.G.
Date:	APR 2021
Scale:	AS SHOWN
As-Built:	

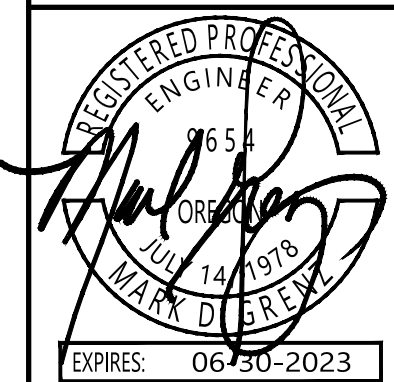

JOB # 7192

**201**

J:\7192\Coburn\_Apts\7192-Coburn\_Apts.dwg, 201-SS, 9/14/2021 9:32:45 AM, TSM

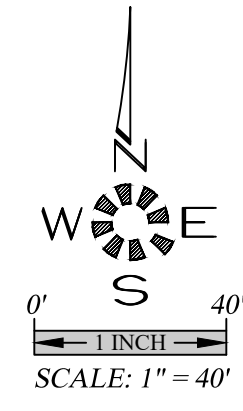
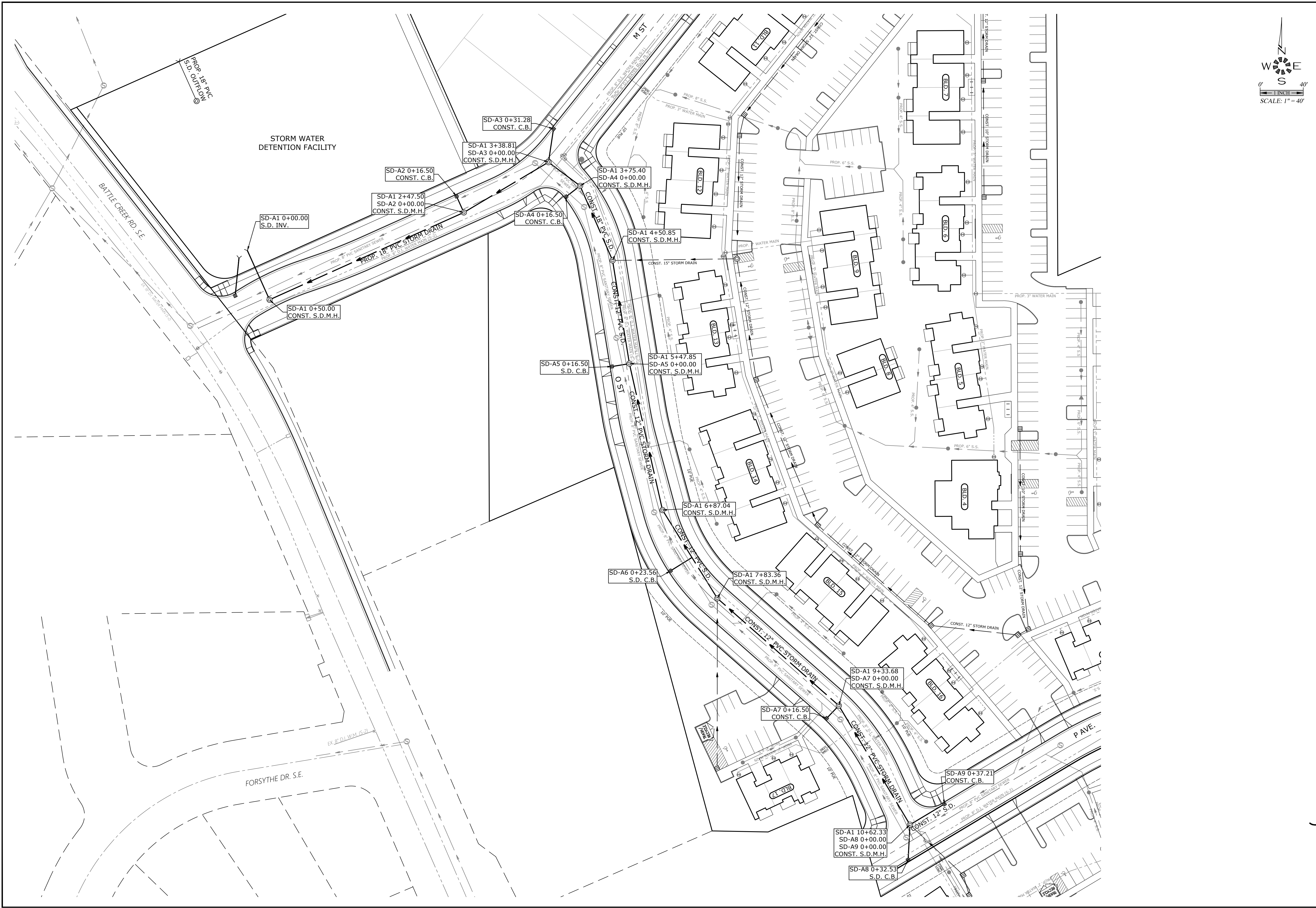

**STORM DRAIN PLAN**

**COBURN APARTMENTS**

NO CHANGES, MODIFICATIONS OR REPRODUCTIONS TO BE MADE TO THESE DRAWINGS WITHOUT WRITTEN AUTHORIZATION FROM THE DESIGN ENGINEER.  
DIMENSIONS & NOTES TAKE PRECEDENCE OVER GRAPHICAL REPRESENTATION.

71929 301-SD  
Design: M.D.G.  
Drawn: T.N.S.  
Checked: J.J.G.  
Date: APR 2021  
Scale: AS SHOWN  
As-Built: \_\_\_\_\_

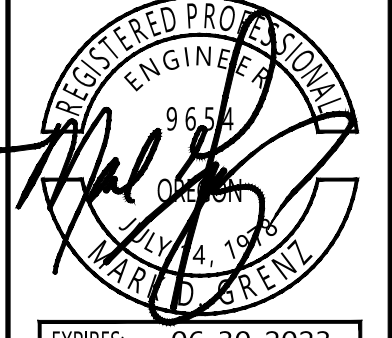

EXPIRES 06-30-2023

JOB # 7192

**301**

J:\7192\Coburn\_Apts\7192-Coburn\_Apts.dwg, 301-SD, 9/14/2021 9:32:46 AM, TSWJL

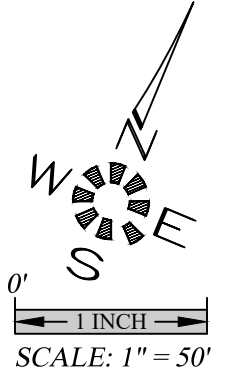

**MULTI/TECH**  
 ENGINEERING SERVICES, INC.  
 1155 13TH ST. S.E. SALEM, OR, 97302  
 PH. (503) 363 - 9227 FAX (503) 364-1260  
 www.mtengineering.net office@mtengineering.net

**STREET PLAN  
 M ST**

**COBURN APARTMENTS**

NO CHANGES, MODIFICATIONS  
 OR REPRODUCTIONS TO BE  
 MADE TO THESE DRAWINGS  
 WITHOUT WRITTEN  
 AUTHORIZATION FROM THE  
 DESIGN ENGINEER.  
 DIMENSIONS & NOTES TAKE  
 PRECEDENCE OVER  
 GRAPHICAL REPRESENTATION.

7192P 401-ST  
 Design: M.D.G.  
 Drawn: T.N.S.  
 Checked: J.J.G.  
 Date: APR 2021  
 Scale: AS SHOWN  
 As-Built: \_\_\_\_\_

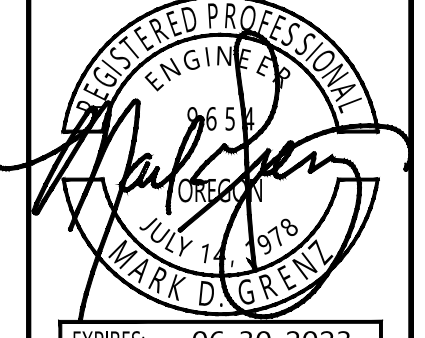

EXPIRES 06-30-2023

JOB # 7192

**401**

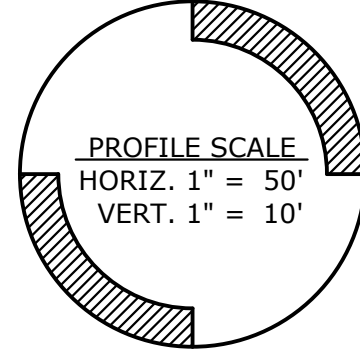
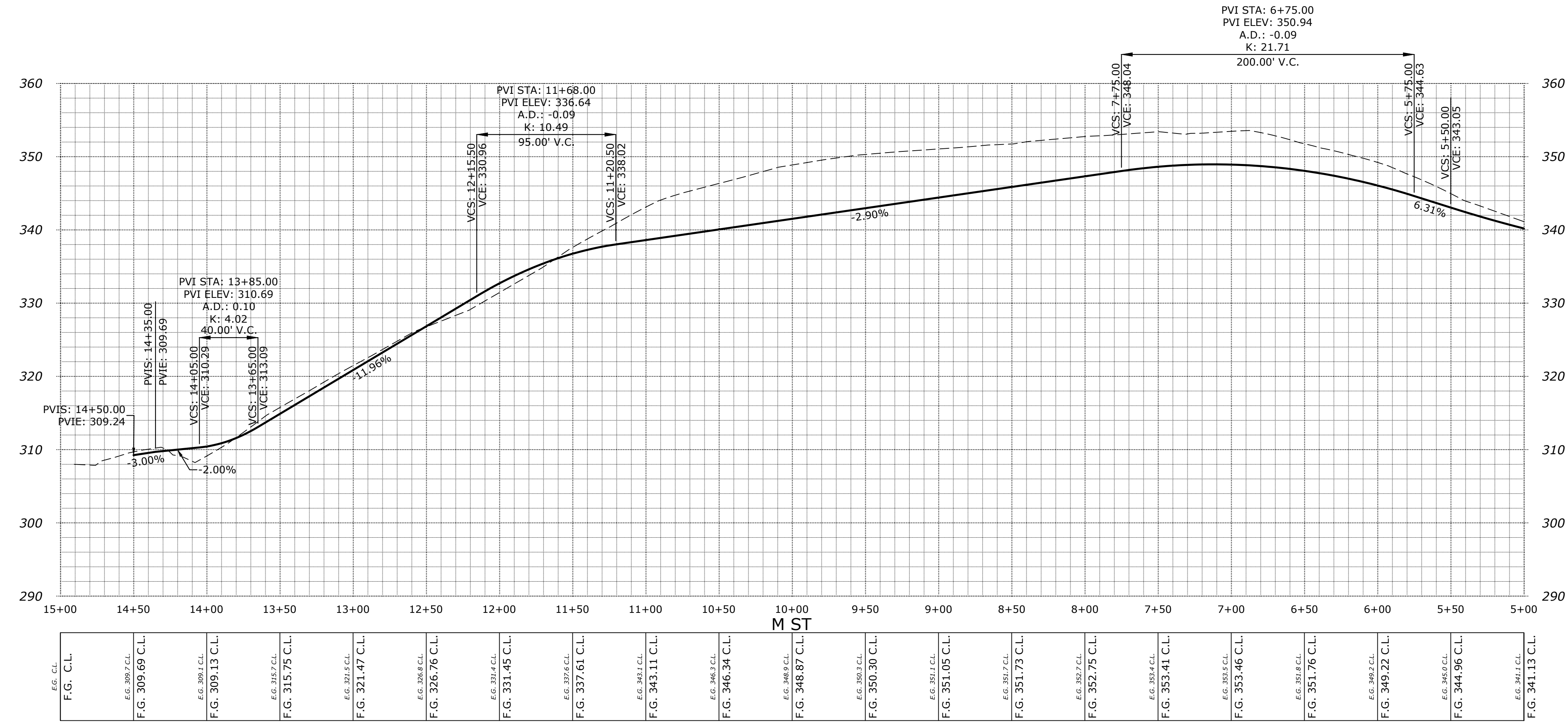

**STREET PLAN**

**COBURN APARTMENTS**

NO CHANGES, MODIFICATIONS OR REPRODUCTIONS TO BE MADE TO THESE DRAWINGS WITHOUT WRITTEN AUTHORIZATION FROM THE DESIGN ENGINEER.  
 DIMENSIONS & NOTES TAKE PRECEDENCE OVER GRAPHICAL REPRESENTATION.

7192P 402-ST  
 Design: M.D.G.  
 Drawn: T.N.S.  
 Checked: J.J.G.  
 Date: APR 2021  
 Scale: AS SHOWN  
 AS-Built: \_\_\_\_\_

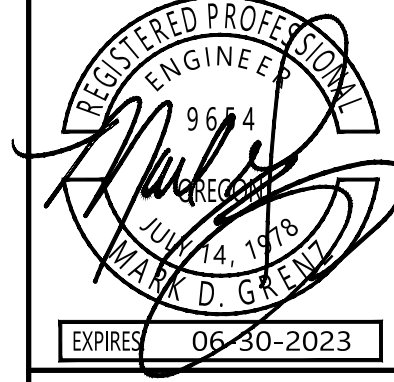

JOB # 7192

**402**

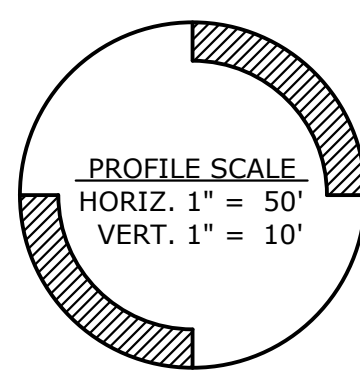
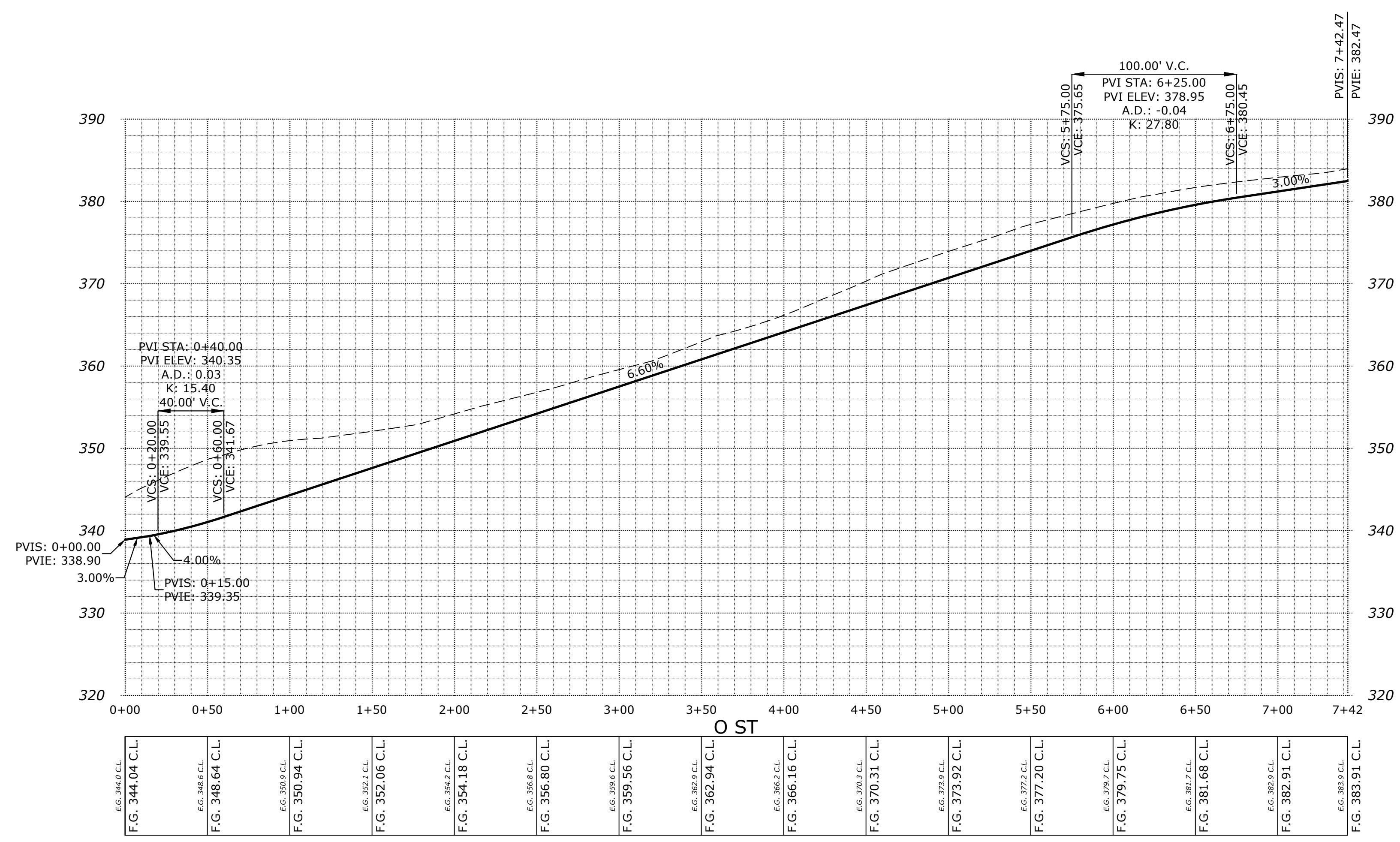
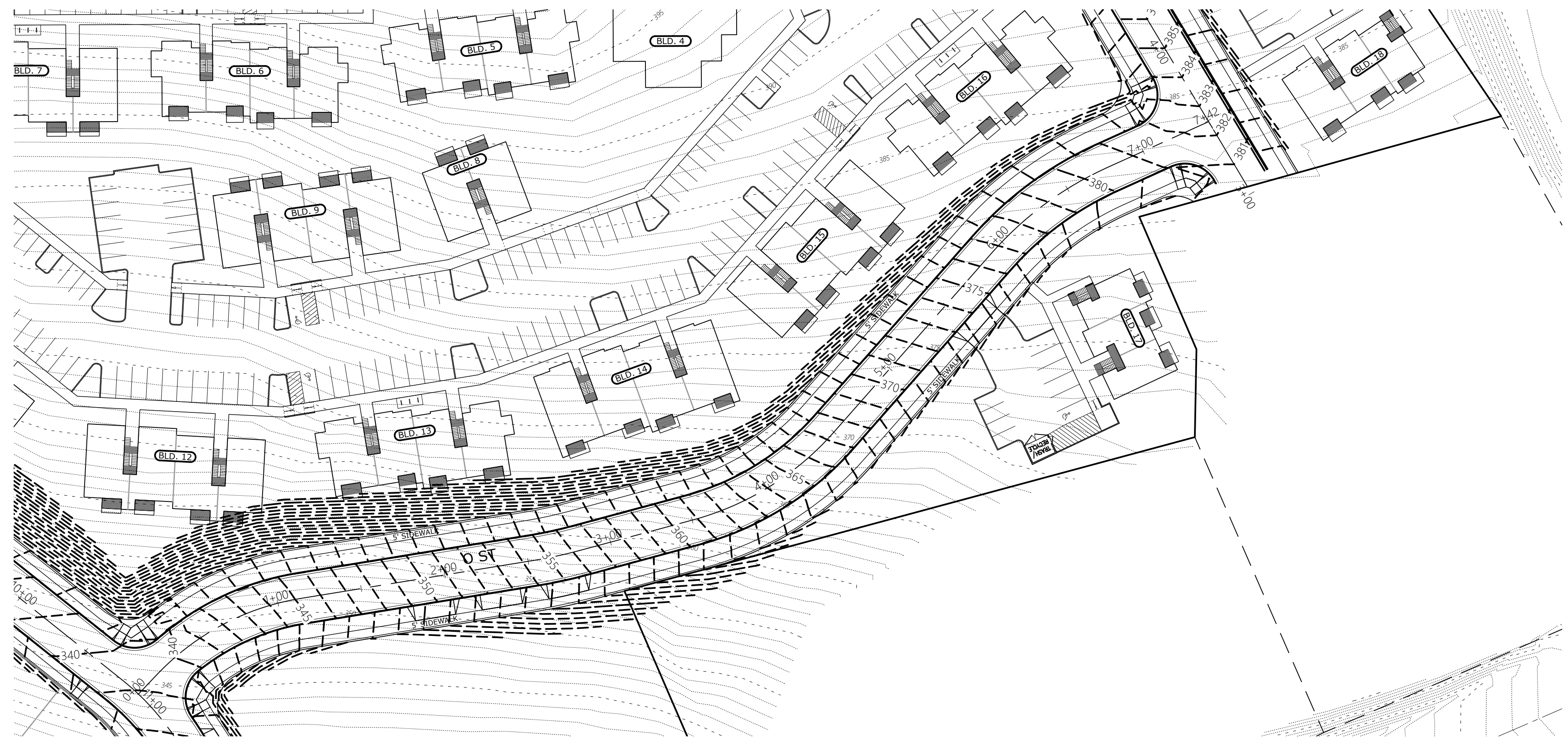
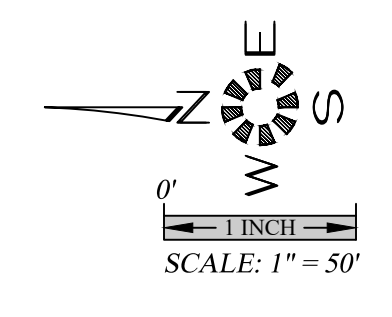

E.G. 344.04 C.L.
E.G. 348.66 C.L.
E.G. 350.94 C.L.
E.G. 352.06 C.L.
E.G. 354.2 C.L.
E.G. 356.80 C.L.
E.G. 359.56 C.L.
E.G. 362.94 C.L.
E.G. 366.16 C.L.
E.G. 370.31 C.L.
E.G. 373.92 C.L.
E.G. 377.2 C.L.
E.G. 379.75 C.L.
E.G. 381.68 C.L.
E.G. 382.9 C.L.
E.G. 382.91 C.L.
E.G. 383.91 C.L.

**STREET PLAN**

**COBURN APARTMENTS**

NO CHANGES, MODIFICATIONS OR REPRODUCTIONS TO BE MADE TO THESE DRAWINGS WITHOUT WRITTEN AUTHORIZATION FROM THE DESIGN ENGINEER.  
 DIMENSIONS & NOTES TAKE PRECEDENCE OVER GRAPHICAL REPRESENTATION.

7192P 403-ST  
 Design: M.D.G.  
 Drawn: T.N.S.  
 Checked: J.J.G.  
 Date: APR 2021  
 Scale: AS SHOWN  
 As-Built: \_\_\_\_\_

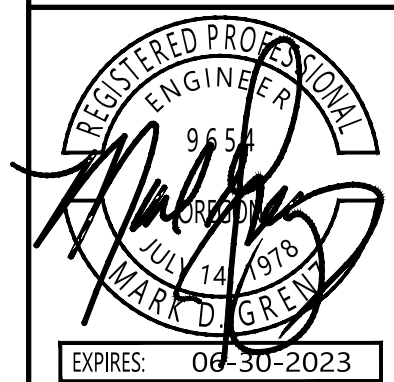

JOB # 7192

**403**

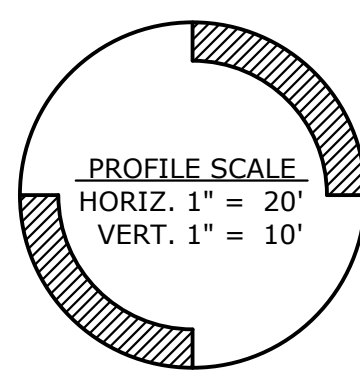
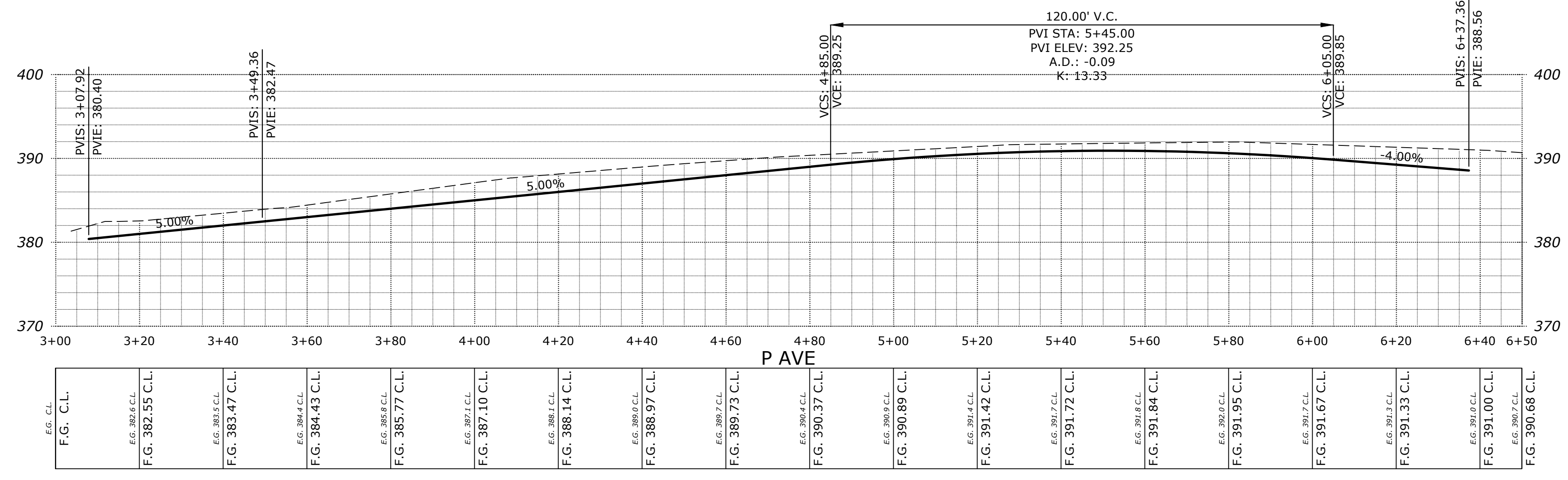
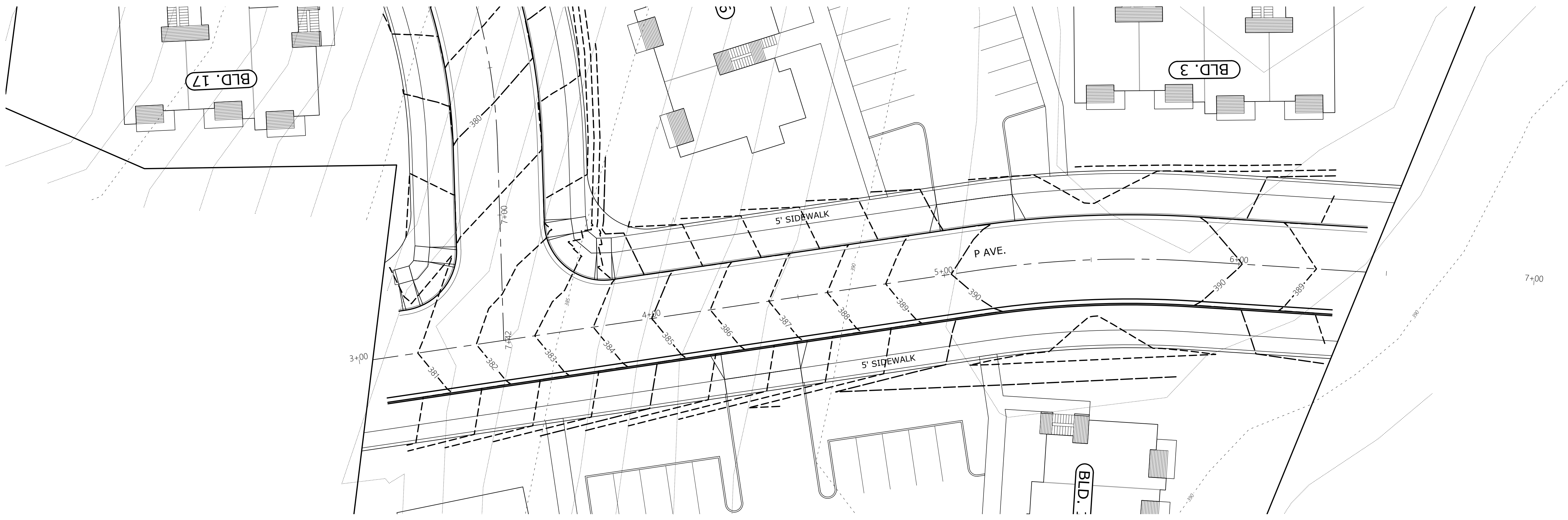
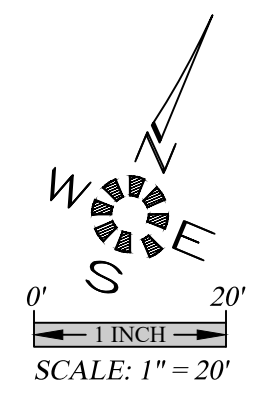

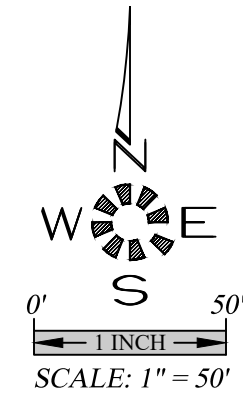

**MULTI/TECH**  
 ENGINEERING SERVICES, INC.  
 1155 13TH ST. S.E. SALEM, OR. 97302  
 PH. (503) 363-9227 FAX (503) 364-1260  
 www.mtengineering.net office@mtengineering.net

**DOMESTIC WATER PLAN**

**COBURN APARTMENTS**

NO CHANGES, MODIFICATIONS OR REPRODUCTIONS TO BE MADE TO THESE DRAWINGS WITHOUT WRITTEN AUTHORIZATION FROM THE DESIGN ENGINEER.  
 DIMENSIONS & NOTES TAKE PRECEDENCE OVER GRAPHICAL REPRESENTATION.

7192P 501-WAT  
 Design: M.D.G.  
 Drawn: T.N.S.  
 Checked: J.J.G.  
 Date: APR 2021  
 Scale: AS SHOWN  
 As-Built: \_\_\_\_\_



EXPIRES 06-30-2023  
 JOB # 7192

J:\7192\Coburn\_Apts\7192-Coburn\_Apts.dwg, 501-WAT, 9/14/2021 8:52:53 AM, T3ball