

The Cannery Salem, Oregon

Preliminary Stormwater Report

Date: March 6, 2024

Client: Trent Michels
15017 Thomas Rd
Charlotte, NC 28278

Engineering Contact: Tyler Roth, PE
503-400-6028 | rotht@aks-eng.com

Prepared By: Madison Margolis

Engineering Firm: AKS Engineering & Forestry, LLC
3700 River Rd N
Suite 1
Keizer, OR 97303

AKS Job Number: 5968-01

Preliminary



www.aks-eng.com

Contents

1.0	Purpose of Report	2
2.0	Project Overview and Description	2
2.1.	Size and Location of Project Site	2
2.2.	Property Scope and Proposed Improvements	2
2.3.	Watershed Description	2
2.4.	Existing Site Conditions	2
2.5.	Existing Trees and Native Vegetation Impact/Preservation	2
2.6.	Green Stormwater Infrastructure to the Maximum Extent Feasible (GSI/MEF)	3
2.7.	Regulatory Permits Required	3
2.8.	Emergency Overflow Escape Route	3
3.0	Methodology	3
3.1.	Depth to Groundwater.....	3
3.2.	Infiltration	3
3.3.	Soils and Geologic Features	3
3.4.	Hazardous Materials	3
4.0	Analysis	3
4.1.	Computational Methods and Software Used	3
4.2.	Design Assumptions	4
4.3.	Hydrology Calculations	4
4.4.	Conveyance Capacity Calculations	4
4.5.	Treatment Sizing	4
5.0	GSI Analysis	5

Tables

Table 4-1:	Rainfall Intensities.....	4
Table 4-2:	Impervious Area Conveyed to Facility	5
Table 4-3:	Peak Elevation Summary.....	5

Figures

Figure 1: Post-Developed Basin Map

Appendices

- Appendix A: Geotechnical Report**
- Appendix B: NRCS Soil Resource Web Survey Results**
- Appendix C: HydroCAD Analysis**
- Appendix D: Operations & Maintenance Form**
- Appendix E: Reduced-Size Grading & Drainage Plan**

Preliminary Stormwater Report

THE CANNERY

SALEM, OREGON

1.0 Purpose of Report

The purpose of this report is to demonstrate compliance with the City of Salem (City) stormwater criteria for land use and site plan review applications. This report is an analysis of the effects the proposed development will have on the existing stormwater conveyance system; document the criteria, methodology, and informational sources used to design the proposed stormwater system; and present the results of the analysis.

2.0 Project Overview and Description

2.1. Size and Location of Project Site

The project site subject to this stormwater report is ± 7.6 acres of the overall site area (± 13.6 acres), located at 1105 Front Street NE, Salem, Marion County, Oregon, Tax Lot 900 of Marion County Assessor's Map 7 3W 22AB. The remaining acreage on the property is anticipated to be developed in a similar manner as a separate phase, but no plans have been confirmed at this time.

2.2. Property Scope and Proposed Improvements

The property is zoned MU-R (Mixed Use-Riverfront). The proposed development involves restoring three existing buildings along the Willamette River, and three new mixed-use buildings including associated parking lots, landscaped areas, utilities, and infrastructure.

2.3. Watershed Description

Current site runoff flows into an existing public stormwater system that ultimately discharges to the Willamette River through existing culverts.

Runoff from the proposed development will be conveyed to several Green Stormwater Infrastructure (GSI) facilities that will provide water quality treatment per City standards. After being treated, runoff will discharge to the existing public storm main that is in the Gaines Street project entrance. Due to the site's location adjacent to the Willamette River, flow control/detention is not required based on city feedback and subsequent discussions.

2.4. Existing Site Conditions

The site currently contains a commercial food distribution warehouse and an abandoned industrial cannery with associated buildings and parking areas. The site up to the top of bank is relatively flat with on-site grades averaging 1.0 percent. Below the top of bank, the site is steep with grades up to 50 percent. The site slopes from a high point of ± 150.25 feet in the northeast corner to a low point of ± 142.86 at the existing storm area drain in the southwest corner of the site.

2.5. Existing Trees and Native Vegetation Impact/Preservation

The portion of the site that is within the riparian buffer and bank slopes includes various trees and vegetation. The remainder of the site is relatively clear of vegetation and is developed. Selected existing trees will be removed as part of the development in accordance with City standards. The majority of the trees and vegetation within the riparian buffer are to remain and will be protected during development.

2.6. Green Stormwater Infrastructure to the Maximum Extent Feasible (GSI/MEF)

This project is classified as a large project because it contains over 10,000 square feet of impervious area. As specified in Section 4.2 of the 2016 City of Salem *Public Works Design Standards*, large projects are required to use GSI to the Maximum Extent Feasible (GSI/MEF) to meet flow control and water quality treatment performance standards. Multiple proposed facilities will be used to meet the GSI/MEF criteria for the proposed site.

2.7. Regulatory Permits Required

Building, tree removal, and site work permits through the City of Salem will be required for the project. Additionally, a DEQ 1200C permit is anticipated to be required due to disturbing more than 1-acre for earthwork.

2.8. Emergency Overflow Escape Route

The stormwater system has been designed to convey stormwater runoff up to the 100-year design storm through a beehive structure that discharges into the existing public system. Emergency overland overflow should the stormwater system be overwhelmed, is into the Willamette River over the site bank slopes.

3.0 Methodology

3.1. Depth to Groundwater

A geotechnical investigation by GeoEngineers was completed on March 24, 2023. Groundwater was encountered approximately 30 feet below existing site grades. Refer to page 3 of the Geotechnical Report (Appendix A) for additional depth to groundwater discussion.

3.2. Infiltration

Infiltration testing performed by GeoEngineers was completed between February 20th and 25th, 2023, at two locations on site. Testing was performed at a depth of ± 5.0 feet below existing site grades. The subgrade soil encountered within the test holes consisted of fine-grained fill and middle terrace deposits. Refer to page 3 of the Geotechnical Report (Appendix A) for additional infiltration testing information.

Infiltration test results from GeoEngineers indicated that the site was not suitable for stormwater infiltration. The proposed GSI facilities do not account for any infiltration through the native soils.

3.3. Soils and Geologic Features

The pre-developed site contains Chehalis Silty Clay Loam, Terrace Escarpments, and Woodburn Silt Loam belonging to Hydrologic Soil Groups B and C respectively, per the Natural Resources Conservation Service (NRCS) Soil Resource Web Survey (Appendix B).

3.4. Hazardous Materials

We are not aware of any existing hazardous material contamination onsite and the geotechnical investigation report does not note any contaminants on site.

4.0 Analysis

4.1. Computational Methods and Software Used

The Soil Conservation Service (SCS) TR-20 method was used to analyze stormwater runoff from the site. This method uses the NRCS Type 1A 24-hour design storm for the region. HydroCAD 10.0-22 computer software aided in the analysis.

4.2. Design Assumptions

The design of the stormwater system was analyzed for runoff generated by the City’s water quality and the 100-year 24-hour design storm events. Due to the site’s location adjacent to the Willamette River, flow control/detention is not a project requirement per City feedback and subsequent discussions.

The following 24-hour rainfall intensities were used for the design storm for the recurrence interval:

Table 4-1: Rainfall Intensities

Recurrence Interval (Years)	Total Precipitation Depth (inches)
Water Quality	1.38
100-year	4.40

The following runoff curve numbers (CN) were used for this analysis:

- Post-Developed – CN = 98; for the preliminary analysis it was assumed that each full basin area was 100 percent impervious surface.
- Growing Medium Filtration Rate = 2.0 inches/hour

A time of concentration for the pre-developed condition was not determined due to the facilities only providing water quality treatment and conveyance.

A minimum time of concentration (Tc) of 6 minutes was used as a direct entry in the stormwater system model for post-developed hydrograph routing, per the 1986 NRCS *Technical Release 55: Urban Hydrology for Small Watersheds (TR-55)*.

4.3. Hydrology Calculations

Tables 4-2 and 4-3 below summarize areas tributary to each facility and the calculated elevations within each facility for post-developed peak flow rates of the water quality and 100-year design storm events. Supporting HydroCAD calculations are provided in Appendix C.

4.4. Conveyance Capacity Calculations

The proposed drainage conveyance system has been designed to convey the peak flows for the 10-year 24-hour storm event per City of Salem *Public Works Design Standards*. The 100-year design storm was analyzed for each facility to identify the peak elevation and available freeboard with each facility at that elevation.

4.5. Treatment Sizing

Water quality and peak flow HydroCAD calculations are provided in Appendix C and summarized in Table 4-3 below, which shows the peak elevation summary for the stormwater facilities during water quality and 100-year design storm events. The water quality design storm event peak elevation is below the overflow elevation for each facility. Therefore, the water quality runoff is fully treated by filtering through the growing medium prior to reaching the facility underdrain and discharge point.

Each facility has been sized with an overflow to convey the 100-year design storm event through a beehive structure. Facilities 1P, 2P, and 3P will treat and convey runoff from the new mixed-use buildings, while facilities 4P and 5P will treat and convey proposed runoff from the drive aisles and newly created impervious areas. Refer to Figure 1 for the post-developed stormwater facility layout.

Table 4-2: Impervious Area Conveyed to Facility

Subbasin ID	Source (roof, road, other)	Impervious Area (square feet)	Facility Ownership (private/public)	Facility Type	Facility Size (square feet)
1S	Roof drain, hardscapes & landscape	44,539	Private	Storm Planter	1,100
2S	Roof drain, hardscapes, & landscape	35,385	Private	Storm Planter	975
3S	Roof drain, hardscapes, & landscape	43,849	Private	Storm Planter	1,000
4S	Hardscapes & landscape	31,106	Private	Storm Planter	545
5S	Hardscapes & landscape	44,865	Private	Rain Garden	1,600

Table 4-3: Peak Elevation Summary

Facility ID	Facility Bottom Elevation (feet)	Peak Elevation, Water Quality (feet)	Beehive Overflow Elevation (feet)	Peak Elevation, 100-Year Event (feet)
1P	145.50 (Above Ground) 142.75 (Rock Bottom)	146.48	146.55	146.69
2P	144.50 (Above Ground) 141.75 (Rock Bottom)	145.27	145.35	145.47
3P	144.00 (Above Ground) 141.25 (Rock Bottom)	145.17	145.25	145.38
4P	140.50 (Above Ground) 137.75 (Rock Bottom)	142.63	142.70	142.81
5P	140.00 (Above Ground) 136.25 (Rock Bottom)	142.14	142.20	142.34

5.0 GSI Analysis

This stormwater report describes the engineering and design process that was used for design of the stormwater facilities for this project. The GSI facilities have been designed in compliance with the *Public Works Design Standards*. Supporting HydroCAD calculations are included in Appendix C.

Runoff from the buildings, parking lot, and immediate surrounding areas will be conveyed to the five proposed GSI facilities discussed previously.

The proposed storm system has been designed to treat over 80 percent of the new or replaced impervious surface and therefore meets the GSI/MEF requirement by using the discretionary approach outlined in 4E.7 of the *Public Works Design Standards*.

Figure 1: Post-Developed Basin Map

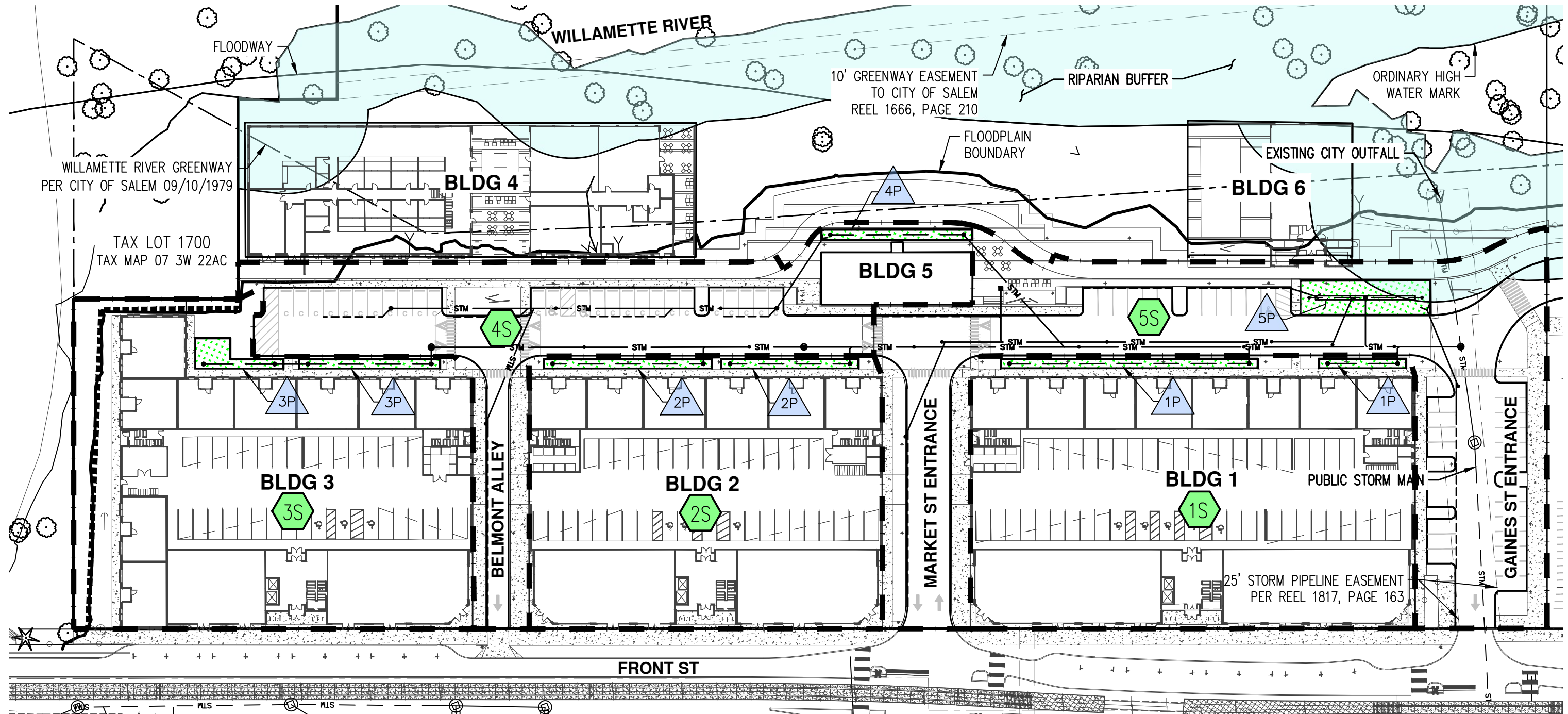

LEGEND

SUBCATCHMENT 

STORMWATER FACILITY 

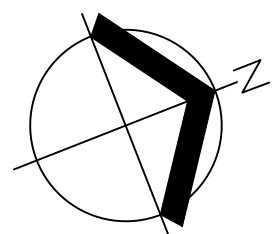

SCALE: 1" = 60 FEET



ORIGINAL PAGE SIZE: 11" x 17"

DATE: 01/18/2024

POST-DEVELOPED BASIN MAP		FIGURE
THE CANNERY		1
AKS ENGINEERING & FORESTRY, LLC 3700 RIVER RD N, STE 1 KEIZER, OR 97303 503.400.6028 WWW.AKS-ENG.COM		DRWN: MJM CHKD: TDR AKS JOB: 5968-01



DWG: 5968-01_20240116_BASIN_MAP | 11X17-L

Appendix A: Geotechnical Report

Geotechnical Engineering Report

Salem Cannery 6-Story Mixed-use Development
Salem, Oregon

for
Future of Neighborhood Development

March 24, 2023

Geotechnical Engineering Report

Salem Cannery 6-Story Mixed-use Development
Salem, Oregon

for

Future of Neighborhood Development

March 24, 2023



333 High Street NE, Suite 102
Salem, Oregon 97301
971.304.3078

Geotechnical Engineering Report
Salem Cannery 6-Story Mixed-use Development
Salem, Oregon

File No. 26595-001-00

March 24, 2023

Prepared for:

Future of Neighborhood Development
808 SW Third Avenue, Suite 800
Portland, Oregon 97204

Attention: Trent Michels

Prepared by:

GeoEngineers, Inc.
333 High Street NE, Suite 102
Salem, Oregon 97301
971.304.3078



EXP 12/1/2023

Brian C. Ranney, CEG
Associate Engineering Geologist

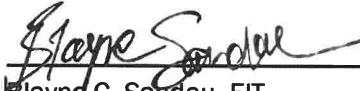
Blayne C. Sandau, EIT
Staff Geotechnical II

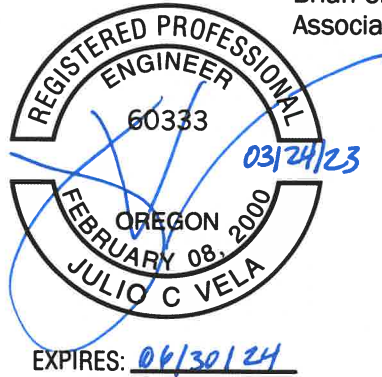

Julio C. Vela, PhD, PE, GE
Principal Geotechnical Engineer

BCS:BCR:JCV:tm

Disclaimer: Any electronic form, facsimile or hard copy of the original document (email, text, table and/or figure), if provided, and any attachments are only a copy of the original document. The original document is stored by GeoEngineers, Inc. and will serve as the official document of record.

Table of Contents

1.0 INTRODUCTION	1
2.0 SCOPE OF SERVICES	1
3.0 SITE DESCRIPTION	1
3.1. Surface Conditions.....	1
3.2. Site Geology	2
3.3. Subsurface Conditions	2
3.3.1. Soil Conditions.....	3
3.3.2. Groundwater Conditions	3
4.0 INFILTRATION TESTING	3
4.1. Suitability of Infiltration System	5
5.0 CONCLUSIONS	5
6.0 EARTHWORK RECOMMENDATIONS	7
6.1. Site Preparation	7
6.1.1. Demolition.....	7
6.1.2. Stripping.....	8
6.1.3. Clearing and Grubbing	8
6.2. Subgrade Preparation and Evaluation.....	8
6.3. Subgrade Protection and Wet Weather Considerations.....	9
6.4. Soil Amendment with Cement.....	10
6.5. Shoring and Temporary Slopes.....	11
6.6. Permanent Slopes	12
6.7. Dewatering.....	12
6.8. Structural Fill and Backfill	13
6.8.1. General.....	13
6.8.2. Use of On-site Soil	13
6.8.3. Imported Select Structural Fill.....	13
6.8.4. Aggregate Base.....	13
6.8.5. Aggregate Leveling Course	14
6.8.6. Trench Backfill.....	14
6.9. Fill Placement and Compaction	14
7.0 STRUCTURAL DESIGN RECOMMENDATIONS	15
7.1. Six-Story Mixed use Residential/Commercial Structures (Blocks 1 through 4).....	15
7.2. Parking Structure (Block 5).....	16
7.3. Foundation Support Alternatives	17
7.3.1. Shallow Foundations on Linn Gravels.....	17
7.3.2. Ground Improvement/Aggregate Piers	17
7.3.3. Deep Foundations	18
7.4. Shallow Foundation Recommendations.....	18
7.5. Shallow Foundation Subgrade Preparation	19
7.6. Shallow Foundation Lateral Resistance	19
7.7. Drainage	19

7.8. Slab on Grade Floors	20
7.8.1. Design Parameters	20
7.9. Seismic Design.....	20
7.9.1. 2018 IBC Seismic Design Parameters.....	20
7.9.2. Liquefaction Potential	21
7.9.3. Lateral Spreading Potential	21
7.10.Retaining Walls	21
7.10.1. Drainage.....	21
7.10.2. Concrete Retaining Walls Design Parameters.....	22
8.0 PAVEMENT RECOMMENDATIONS	23
8.1. Drainage	23
8.2. On-Site Asphalt Concrete (AC) Pavement Sections.....	23
8.3. Front Street NE.....	25
8.3.1. Existing Pavement Section.....	25
8.3.2. Asphalt Concrete Pavement Design.....	26
8.3.3. Portland Cement Concrete Pavement Design	27
9.0 DESIGN REVIEW AND CONSTRUCTION SERVICES	28
10.0 LIMITATIONS.....	28
11.0 REFERENCES.....	28

LIST OF FIGURES

- Figure 1. Vicinity Map
- Figure 2. Site Plan
- Figure 3. Cross Section A-A'

APPENDICES

- Appendix A. Field Explorations and Laboratory Testing
 - Figure A-1. Key to Exploration Logs
 - Figures A-2 through A-14. Logs of Drilled Borings
 - Figures A-15 through A-18. Logs of CPT Soundings
 - Figure A-19. Atterberg Limits Test Results
- Appendix B Geologic Hazard Assessment
- Appendix C. Report Limitations and Guidelines for Use

1.0 INTRODUCTION

GeoEngineers, Inc. (GeoEngineers) is pleased to submit this geotechnical engineering report for proposed Future of Neighborhood Development Salem Cannery 6-Story Mixed-use Development (Salem Cannery) Project. The Salem Cannery is located on four blocks along Front Street NE between Belmont Street NE to Shipping Street NE in Salem, Oregon. The location of the site is shown on the Figure 1, Vicinity Map.

A preliminary site development drawing for the project by LRS Architects, was provided to the project team. The plan is titled "Salem Cannery Prelim Design" dated January 1, 2023. Based on discussions with the project team and the preliminary site plan, the project will consist of constructing one 3-story, concrete parking structure (block 5), four new 6-story mixed-use buildings (Blocks 1 through 4), associated underground utilities and paved parking areas and drive aisles, and one below grade parking level spanning beneath blocks 3, 4 and 5 in the first phase of development. Future phases of development will extend northward to Blocks 1 and 2.

In addition, the project will include off-site improvements to Front Street NE, site access drives that are extensions of east-west trending city streets at each block, and adaptive reuse of some existing structures along the west side of proposed blocks 3 and 4 and east of Front Street SE southeast of block 4.

Existing site conditions are presented on the Figure 2, Site Plan. Our recommendations for structural development for the site are based on estimated column and wall loads on the order of 575 and 10 kips per lineal foot (klf), respectively, and slab loads of 250 pounds or less as provided by F40ELICH Engineers (Structural Engineer). If design loads exceed these values our recommendations may need to be revised.

2.0 SCOPE OF SERVICES

Our specific scope of services is detailed in our January 31, 2023, proposal to you. Our original scope of services was authorized on February 1, 2023. In general, our scope of services included: reviewing selected geotechnical information about the site; performing a geologic reconnaissance; exploring subsurface soil and groundwater conditions; collecting representative soil samples; completing infiltration testing at the site; completing relevant laboratory testing and geotechnical analyses; conducting a site-specific seismic hazard evaluation for the proposed project; and providing this geotechnical report with our conclusions, findings and design recommendations.

3.0 SITE DESCRIPTION

3.1. Surface Conditions

The project site comprises approximately 11 acres located between the east bank of the Willamette River and Front Street NE between Belmont Street NE just north of the bridge over Mill Creek on Front Street NE, and Shipping Street NE in Salem, Oregon. The site is occupied by buildings and equipment formerly used for industrial food processing plants dating back to the early 1900s.

The property is bounded by a slope that grades down to the Willamette River to the west, Front Street NE to the east, commercial properties to the north and a gabion basket retaining wall overlooking a creek to the south. The project site is currently developed with the existing industrial food processing facility (Truitt Cannery), administrative support buildings and paved parking and associated underground utilities located

in the southern two-thirds of the site as shown on Figure 2. Site grades are generally flat or sloping gently away from the existing structures as part of the previous site grading, except along the west margin of the site where it slopes down more steeply toward the Willamette River (west) and the southern portion of the site where a nearly vertical face retained by a gabion basket wall is located. At the time of this report, the team did not have design or construction information with respect to the gabion wall. Asphalt concrete (AC) and portland cement concrete (PCC) hardscape pavements or gravel parking areas and grassy equipment laydown and general storage areas border the buildings.

3.2. Site Geology

The geology of the site is mapped by the *Geology of the Rickreall, Salem West, Monmouth and Sidney Quadrangles, Marion, Polk, and Linn Counties, Oregon* (Bela 1981) as stretching across the contact of two geologic units.

The southern portion of the site – from roughly the alignment of Hood Street NE to the southwestern edge of the site along Mill Creek - is mapped as underlain by Pleistocene-age Linn Gravels. These materials typically consist of “...stratified fine to coarse fluvial gravels deposited as an alluvial fan...by an early stage of the Santiam River.” Our explorations suggest that this coarse alluvium underlies the entire site at depth, ranging from less than 5 feet below ground surface (bgs) near the center of the site to as much as 20 to 25 feet bgs near the northeast and southwest perimeters.

Northeast of Hood Street to the northeast edge of the site along Shipping Street NE the published mapping and our investigation suggests that the Linn Gravel is mantled by what Bela (1981) terms “Middle Terrace Deposits” and describes as “...10-30 feet of light brown silty clay and interbedded very fine sand and silt...” that the mapping equates with the Willamette Silt flood deposit alluvium typically encountered as valley fill across the lower Willamette Valley. Our subsurface investigation suggests that the actual contact between the shallow Linn Gravels and the mantle of Middle Terrace Deposits is further southwest than is mapped, probably between the alignments of Market and Gaines Streets.

Although not mapped by Bela (1981), our explorations and experience in the area indicates that the site is mantled by fill of variable thickness that generally increases to the south as a result of historical site grading.

Our review of the site geology, together with on-site observations, suggests that the site geology is generally consistent with the published mapping and our experience in the area, except for the fill as noted above.

3.3. Subsurface Conditions

Subsurface conditions at the site were explored by advancing 13 drilled borings (B-1 through B-13), 4 cone penetration soundings (CPT-1 through CPT-4), and 4 ground penetrating radar soundings completed between February 20, and February 25, 2023. Drilled borings were advanced to a final depth between 16.5 and 41.5 feet bgs and the cone penetrometer tests (CPTs) were advanced to refusal approximately between 6.5 and 19 feet bgs. The approximate locations of the explorations completed at the site are shown on Figure 2. Logs of GeoEngineers’ explorations completed for this study are presented in Appendix A, Field Explorations and Laboratory Testing.

Soil samples obtained during site exploration were taken to GeoEngineers' laboratory for further evaluation. Selected samples were tested for determination of moisture content and Atterberg Limit Determinations. A description of the laboratory testing, and the test results are presented in Appendix A.

3.3.1. Soil Conditions

The site soils can be generally divided into three general categories: Man-made Fill, Middle Terrace Deposits and Linn Gravels. Some blending or alluvial soil interfaces may be present, but we consider the descriptions below to be the dominant soils present at the site.

3.3.1.1. Man-made Fill

A highly variable mix of silt, sand and gravel fill was encountered in four of the borings and one CPT located in the southwestern portions of the site. The materials ranged from 4 to 5 feet of soft to medium stiff silt encountered in B-1 and B-4, roughly 9½ feet of loose silty gravel and silty sand in B-2, approximately 13 feet of soft to medium stiff silt in B-4, and up to 23 feet of loose to very dense silty gravel and soft silt in B-13. This material was likely used to level the low-lying portions of the site that formed the former Mill Creek and Willamette River confluence and are likely to include an even wider range of materials including possibly wood and man-made debris.

3.3.1.2. Middle Terrace Deposits

The central and northeastern portions of the site are mantled by a thickening to the northeast wedge of soft to stiff silt and loose to medium dense fine sand we interpret as the mapped Middle Terrace Deposits. The thickness of these deposits ranges from roughly 6 to 7 feet in B-5 and B-6 to approximately 18 to 20 feet in B-7, B-12 and B-10.

3.3.1.3. Linn Gravels

Underlying the fill to the southwest and the Middle Terrace Deposits to the northeast we encountered medium dense to very dense silty gravel and poorly-graded gravel with sand and silt that we interpret as the mapped Linn Gravels to the maximum depth explored. Several borings encountered layers of silt or sand that we interpret as natural interbeds of alluvial materials deposited during low-energy episodes of Willamette and Santiam River deposition.

3.3.2. Groundwater Conditions

Groundwater was encountered at approximately 30 feet bgs in B-6 and B-13. Based on our experience at nearby sites the regional groundwater level is likely related to the level of the Willamette River, although shallow seasonal ("perched") groundwater may be encountered at shallower depths during the wet winter and spring months of the year.

4.0 INFILTRATION TESTING

As requested by the project team, we conducted two on-site infiltration tests to assist in the evaluation of the site for stormwater infiltration design at the exploration location noted as IT-1 and IT-2 on Figure 2. The testing was conducted at a depth of 5 feet bgs.

On site testing was conducted in general accordance with the professional encased falling head procedure outlined in development design standards of multiple Oregon jurisdictions. Our general procedure included drilling a 4-inch-diameter hole to insert a polyvinyl chloride (PVC) pipe for the encased falling head procedure at a depth of 4 feet bgs.

The encased PVC pipe was filled with clean water to approximately 1 foot above the soil at the bottom of the drilled hole. The initial fill of water did not drain into the soil within 10 minutes, so the water level was maintained, and the soil allowed to saturate for 4 hours at the test locations. The levels were checked, and the pipes were refilled to 12 inches above the soil in the bottom of the pipe at the end of each hour and for multiple days after initiating the test. The drop-in water level was measured during three, hour-long iteration periods at the test locations. Field test results are summarized in Table 1.

TABLE 1. FIELD MEASURED INFILTRATION RESULTS

Infiltration Test No.	Location	Depth (feet)	USCS Material Type	Field Measured Infiltration Rate ¹ (in/hr)
IT-1	See Site Plan	5	GM (Fill)	12
IT-2	See Site Plan	5	ML (Middle Terrace)	0 - 0.1

Notes:

¹ Appropriate factors should be applied to the field-measured infiltration rate, based on the design methodology and specific system used.

USCS = Unified Soil Classification System; in/hr = inches per hour

Infiltration rates shown in Table 1 represent a field-measured infiltration rate. The rates summarized for IT-2 and IT-3 indicate effectively 0 in/hr because minimal to no infiltration (drop in water levels) was observed during the testing period. Field measurements are limited to the accuracy of equipment employed to conduct the test. Actual long-term infiltration rates of the on-site soils are likely greater than 0 in/hr if measured out over very long-time frames (much longer than the time frames prescribed in the testing standards). A field-measured rate of 0 in/hr generally indicates infiltration less than 1/8 inch per hour, which is about the limit of the field measuring equipment.

In addition, field-measured rates represent a relatively short-term infiltration rate, and factors of safety have not been applied for the type of infiltration system being considered or for variability that may be present across large areas in the on-site soil. In our opinion, and consistent with the state of the practice, correction factors should be applied to this measured rate to reflect the localized area of testing relative to the field sizes.

Appropriate correction factors should also be applied by the project civil engineer to account for long-term infiltration parameters. From a geotechnical perspective, we recommend a factor of safety (correction factor) of at least 2 be applied to the field infiltration values to account for potential soil variability with depth and location within the area tested. In addition, the stormwater system design engineer should determine and apply appropriate remaining correction factor values, or factors of safety, to account for repeated wetting and drying that occur in this area, degree of in-system filtration, frequency and type of system maintenance, vegetation, potential for siltation and bio-fouling, etc., as well as system design correction factors for overflow or redundancy, and base and facility size.

Actual depths, lateral extent and estimated infiltration rates can vary from the values presented above. Field testing/confirmation during construction is often required in large or long systems or other situations where soil conditions may vary within the area where the system is constructed. The results of this field testing might necessitate that the infiltration locations be modified to achieve any appreciable design infiltration rate. In no case, however, do we recommend infiltration within 50 feet of the adjacent slopes to the west. The infiltration flow rate of a focused stormwater system like a drywell or small infiltration box or

pond typically diminishes over time as suspended solids and precipitates in the stormwater further clog the void spaces between the soil particles or cake on the infiltration surface or in the engineered media. The serviceable life of an infiltration media in a stormwater system can be extended by pre-filtering or with on-going accessible maintenance. Eventually, most systems will fail and will need to be replaced or have media regenerated or replaced.

We recommend that infiltration systems not be located within 50 feet of the adjacent slope to the west. In addition, for infiltration systems located anywhere on site an overflow that is connected to a suitable discharge point should be provided. Also, infiltration systems can cause localized, high groundwater levels and should not be located near basement walls, retaining walls or other embedded structures unless these are specifically designed to account for the resulting hydrostatic pressure. Infiltration locations should not be located on sloping ground, unless it is approved by a geotechnical engineer, and should not be infiltrated at a location that allows for flow to travel laterally toward a slope face, such as a mounded water condition or too close to a slope face that could cause instability of the slope.

4.1. Suitability of Infiltration System

Successful design and implementation of stormwater infiltration systems and whether a system is suitable for development depends on several site-specific factors. Stormwater infiltration systems are generally best suited for sites having sandy or gravelly soil with saturated hydraulic conductivities greater than 2 in/hr. Sites with silty or clayey soil, are generally not well-suited for long-term stormwater infiltration or as a sole method of stormwater infiltration. Soils that have fine-grained matrices are susceptible to volumetric change and softening during wetting and drying cycles. Fine-grained soils also have large variations in the magnitude of infiltration rates because of bedding and stratification that occurs during alluvial deposition, and often have thin layers of less permeable or impermeable soil within a larger layer. As a result of fine-grained soil conditions and relatively low field measured infiltration rates over portions of the site mantled by fine-grained fill and middle terrace deposits, and proximity to existing slopes in portions of the site mantled with fill, we recommend infiltration of stormwater not be used in as the sole method of stormwater management.

We understand that stormwater infrastructure on the site will include vegetated swales (rain gardens) that will treat site stormwater before being discharged to a suitable drainage system. Where located within 50 feet of the crest of existing slopes, vegetated swales for stormwater treatment should be lined with an impervious geomembrane to prevent infiltration of stormwater that could negatively affect slope stability.

5.0 CONCLUSIONS

Based on our explorations, testing and analyses, it is our opinion that the site is generally suitable for the proposed development from a geotechnical engineering standpoint, provided the recommendations in this report are included in design and construction. As a result of relatively high column and wall structural loads, building foundations should be supported on a system of compacted aggregate piers (CAPs) or extended-depth foundations. Fill encountered in the southwest portion of the site will also require structural loads to be supported on inclusions (CAPs or extended-depth foundations) to depths below the fill layer and to depths that transfer loads sufficiently deep so that additional vertical or lateral loads are not applied to the existing gabion wall. The existing gabion wall was observed to have been compromised over a portion of its extent (blowout of facing) and will require repair or replacement as part of site development.

A summary of the primary geotechnical considerations is provided below. The summary is presented for introductory purposes only and should be used in conjunction with the complete recommendations presented in this report.

- Due to the fines content of the upper soils at the site, they will likely become disturbed by construction traffic from earthwork occurring during periods of wet weather or when the moisture content of the soil is more than a few percentage points above optimum. Wet weather construction practices will be required, except during the dry summer months.
- On-site soils may be reused as structural fill; however, the material is considered moisture sensitive and may not be suitable for reuse except during the driest of summer months. On-site material will be practically unworkable as structural fill during the wet season or when prolonged wet weather persists. In general, the most persistent wet weather in the area occurs from early October to mid-May. The blackish upper silt material observed is generally not recommended for reuse as structural fill.
- The site is generally poorly suited for stormwater infiltration as a method of handling site stormwater. Infiltration should not be used as the sole method for handling site stormwater and should not be used adjacent to slopes. Vegetated swales (rain gardens) for stormwater treatment should be lined with an impervious geomembrane to prevent infiltration of site stormwater where it could negatively affect slope stability.
- Based on the maximum design column and wall loads provided by the project structural engineer, we recommend that proposed structures with column loads greater than 180 kips and wall loads greater than 5 klf be supported on shallow spread foundations bearing on subgrade improved by compacted aggregate piers or rigid inclusions, or be founded on extended-depth foundations such as driven piles or drilled shafts. Ground improvements using CAPs or rigid inclusions used as ground improvement should be designed to a performance criterion that is acceptable to the structural engineer and project team, typically less than 1 inch of allowable settlement.
- Based on our discussions with the project team, block 5 may be constructed at a zero offset from the south and west property corner, near an approximately 20-foot-tall (in some spots) gabion wall along Mill Creek on the southwest corner boundary of the project site. As detailed in the Geologic Hazard Assessment included in Appendix B, the existing wall has blown out (broken) in at least one area and the remaining wall is considered marginally stable as a result of foundation undermining and will require repair or demolition and replacement based on the preferred configuration for block 5.
- New foundations for the proposed block 5, whichever alternative is selected, should be designed and constructed in a manner that loads downward beyond a depth that would impose additional vertical or lateral load to the existing gabion wall if it is to remain in place. In addition, any structural elements extending behind the gabion wall should not be designed for passive lateral resistance from soil retained by the gabion system within a 2H:1V (horizontal to vertical) projection back from the base of the wall.
- If the existing gabion wall is not removed and shallow foundations are the preferred alternative for block 5, the existing wall should be repaired and foundation elements for block 5 should be located outside of a 2H:1V projection from the bottom of the gabion wall. Spread footings should be founded on subgrade improved by rammed aggregate piers.

Alternatively, the existing wall could be repaired and block 5 could be satisfactorily founded on rigid inclusions or shallow foundations over subgrade improved by CAPs located within the recommended

setback distance, provided that they can be designed to impose no additional lateral load on the existing gabion wall.

- If the existing gabion wall is demolished (excavated down and regraded) or encased and replaced by a permanent wall to facilitate the configuration of block 5 as a zero-offset structure, the new wall should be designed for at-rest earth pressures as it will be restrained top and bottom by horizontal structural elements, and should account for additional loading from newly constructed foundations.
- If ground improvement is not completed at the site, post-construction settlement from the underlying compressible soils under the design loads are anticipated to exceed 1-inch total. We estimate settlements on the order of 2.5 to 3.5 inches, with about ½ of that magnitude occurring as differential settlement over a distance of approximately 50 feet.
- Relatively lightly loaded floor slabs (250 pounds per square foot [psf] loads or less) can be supported on aggregate base placed on native medium stiff/medium dense or stiffer/denser soils or on structural fill placed over native soils. Structural slabs should be supported on a minimum 6-inch-thick compacted crushed rock base.
- Standard pavement sections prepared as described in this report will suitably support the estimated traffic loads, provided the site subgrade is prepared as recommended. Maintenance and repair will likely be required following the design level earthquake.
- We observed groundwater at a depth of approximately 30 feet bgs.

6.0 EARTHWORK RECOMMENDATIONS

6.1. Site Preparation

In general, site preparation and earthwork for site development will include demolition and removal of existing structures and hardscapes, removal or relocation of existing site utilities where present beneath proposed building footprints, excavation for removal of existing foundation elements, tree and tree root removal, grading the site and excavating for utilities and foundations.

6.1.1. Demolition

All existing structural elements should be excavated and removed from proposed structural areas including above-ground structures, below-grade basement structures, concrete flatwork, rail lines or conduit, stripping of site vegetation in the north blocks, and removal or known and potentially buried and previously abandoned subsurface support elements. If present, existing utilities that will be abandoned on site should be identified prior to project construction. Abandoned utility lines larger than 4 inches in diameter that are located beneath proposed structural areas should be completely removed or filled with grout if abandoned and left in place in order to reduce potential settlement or caving in the future.

In general, demolished material should be transported off site for disposal. Excavations left from demolition of existing development should be backfilled with compacted structural fill as recommended in this report. The bottom of the excavations should be excavated to expose firm subgrade. The sides of the excavations should be cut into firm material and sloped a minimum of 1H:1V. Excavations should not undermine adjacent foundations, walkways, streets or other hardscapes unless special shoring or underpinning is provided. Excavations should not be conducted within an outward and downward projection of a 1H:1V line starting at least 2 feet outside the edge of an adjacent structural feature.

6.1.2. Stripping

Areas to receive fill, structures or pavements should be cleared of vegetation and stripped of topsoil. Based on our observations at the site, we estimate that the depth of stripping will generally be on the order of 2 to 6 inches where vegetation is present with increased depths in areas of thicker vegetation.

Greater stripping depths may be required to remove localized zones of loose or organic soil. The actual stripping depth should be based on field observations at the time of construction. Stripped material should be transported off site for disposal unless otherwise allowed by project specifications for other uses such as landscaping. Clearing and grubbing recommendations provided below should be used in areas where moderate to heavy vegetation are present, or where surface disturbance from prior use has occurred.

6.1.3. Clearing and Grubbing

Where thicker vegetation (brush and trees) is present, more extensive site clearing will be required to remove site vegetation, including thick grass, shrubs and trees that are designated for removal. Following clearing, grubbing and excavations up to several feet will be required to remove the root zones of thick shrubs and trees. Deeper excavations, up to 5 or 6 feet may be required to remove the root zones of large trees if encountered. In general, roots larger than ½ inch in diameter should be removed. Excavations to remove root zones should be done with a smooth-bucket to minimize subgrade disturbance. Portions of the site are heavily vegetated and previously buried roots may be present, even in the current grassy areas of the site. Grubbed materials should be hauled off site and properly disposed of unless otherwise allowed by the project specifications for other uses such as landscaping, stockpiling or on-site burning.

Existing voids and new depressions created during demolition, clearing, grubbing or other site preparation activities, should be excavated to firm soil and backfilled with Imported Select Structural Fill. Greater depths of disturbance should be expected if site preparation and earthwork are conducted during periods of wet weather.

6.2. Subgrade Preparation and Evaluation

Upon completion of site preparation activities, exposed subgrades should be proof-rolled with a fully loaded dump truck or similar heavy rubber-tired construction equipment where space allows to identify soft, loose or unsuitable areas. Probing may be used for evaluating smaller areas or where proof-rolling is not practical. Proof-rolling and probing should be conducted prior to placing fill and should be performed by a representative of GeoEngineers who will evaluate the suitability of the subgrade and identify areas of yielding that are indicative of soft or loose soil. If soft or loose zones are identified during proof-rolling or probing, these areas should be excavated to the extent indicated by our representative and replaced with structural fill.

As discussed in Section 6.3 Subgrade Protection and Wet Weather Considerations of this report, because of the fines content native clayey soil can be sensitive to small changes in moisture content and will be difficult, or not possible, to compact adequately during wet weather. While tilling and compacting the subgrade is the economical method for subgrade improvement, it will likely only be possible during extended dry periods and following moisture-conditioning of the soil.

During wet weather, or when the exposed subgrade is wet or unsuitable for proof-rolling, the prepared subgrade should be evaluated by observing excavation activity and probing with a steel foundation probe.

Observations, probing and compaction testing should be performed by a member of our staff. Wet soil that has been disturbed due to site preparation activities or soft or loose zones identified during probing should be removed and replaced with compacted structural fill.

6.3. Subgrade Protection and Wet Weather Considerations

The upper clayey soils at the site are extremely susceptible to moisture. Wet weather construction practices will be necessary if work is performed during periods of wet weather. If site grading will occur during wet weather conditions, it will be necessary to use track-mounted equipment, load material into trucks supported on gravel work pads and employ other methods to reduce ground disturbance. The contractor should be responsible to protect the subgrade during construction reflective of their proposed means and methods and time of year.

Earthwork planning should include considerations for minimizing subgrade disturbance. The following recommendations can be implemented if wet weather construction is considered:

- The ground surface in and around the work area should be sloped so that surface water is directed to a sump or discharge location. The ground surface should be graded such that areas of ponded water do not develop. Measures should be taken by the contractor to prevent surface water from collecting in excavations and trenches. Measures should be implemented to remove surface water from the work area.
- Earthwork activities should not take place during periods of heavy precipitation.
- Slopes with exposed soils should be covered with plastic sheeting or similar means.
- The site soils should not be left uncompacted and exposed to moisture. Sealing the surficial soils by rolling with a smooth-drum roller prior to periods of precipitation will reduce the extent to which these soils become wet or unstable.
- Construction activities should be scheduled so that the length of time that soils are left exposed to moisture is reduced to the extent practicable.
- Construction traffic should be restricted to specific areas of the site, preferably areas that are surfaced with working pad materials not susceptible to wet weather disturbance such as haul roads and rockered staging areas.
- When on-site fine-grained soils are wet of optimum moisture, they are easily disturbed and will not provide adequate support for construction traffic or the proposed development. The use of granular haul roads and staging areas will be necessary for support of construction traffic. Generally, a 12- to 16-inch-thick mat of imported granular base rock aggregate material is sufficient for light staging areas for the building pad and light staging activities but is not expected to be adequate to support repeated heavy equipment or truck traffic. The granular mat for haul roads and areas with repeated heavy construction traffic should be increased to between 18 and 24 inches. The actual thickness of haul roads and staging areas should be based on the contractor's approach to site development and the amount and type of construction traffic.
- During periods of wet weather, concrete should be placed as soon as practical after preparation of the footing excavations. Foundation bearing surfaces should not be exposed to standing water. If water collects in the excavation, it should be removed before placing structural fill or reinforcing steel.

Subgrade protection for foundations consisting of a lean concrete mat may be necessary if footing excavations are exposed to extended wet weather conditions.

During wet weather, or when the exposed subgrade is wet or unsuitable for proof-rolling, the prepared subgrade should be evaluated by observing excavation activity and probing with a steel foundation probe. Observations, probing and compaction testing should be performed by a member of our staff. Wet soil that has been disturbed due to site preparation activities or soft or loose zones identified during probing should be removed and replaced with compacted structural fill.

6.4. Soil Amendment with Cement

As an alternative to using Imported Select Structural Fill material for wet weather structural fill, an experienced contractor may be able to amend the on-site soil with portland cement concrete (PCC) to obtain suitable support properties. It is often less costly to amend on-site soils than to remove and replace soft soils with imported granular materials. Single pass tilling depths for cement amendment equipment is typically 18 inches or less. However, multiple tilling passes may be required to adequately blend in the cement with the soils and to sufficiently process the soils. It may also be necessary to place the recommended cement quantities in multiple passes between tilling passes, which requires intermediate compaction.

The contractor should be responsible for selecting the means and methods to construct the amended soil without disturbing exposed subgrades. We recommend low ground-pressure (such as balloon-tired) cement spreading equipment be required. We have observed other methods used for spreading that have resulted in significant site disturbance and high remedial costs. For example, we have observed amendment efforts using a spreader truck equipped with road tires pulled by track-mounted equipment that resulted in significant disturbance to the work area and required re-working large areas of cement-amended product at additional expense.

Areas of standing water, or areas where traffic patterns are concentrated and disturbing the subgrade, will also create a need for higher amounts of cement to be applied and additional tilling for better mixing and cement hydration prior to final compaction.

Successful use of soil amendment depends on the use of correct mixing techniques, the soil moisture content at the time of amendment and amendment quantities. Specific recommendations, based on exposed site conditions for soil amending, can be provided if necessary. However, for preliminary planning purposes, it may be assumed that a minimum of 5 percent cement (by dry weight, assuming a unit weight of 100 pounds per cubic foot [pcf]) will be sufficient for improving on-site soils. Treatment depths of 12 to 16 inches are typical (assuming a 7-day unconfined compressive strength of at least 80 pounds per square inch [psi]), although they may be adjusted in the field depending on site conditions. Soil amending should be conducted in accordance with the specifications provided in Oregon Structural Specialty Code (OSSC) 00344 (Treated Subgrade).

We recommend a target strength for cement-amended soils of 80 psi. The amount of cement used to achieve this target generally varies with moisture content and soil type. It is difficult to predict field performance of soil-to-cement amendment due to variability in soil response and we recommend laboratory testing to confirm expectations. However, for preliminary design purposes, 4 to 5 percent cement by weight of dry soil can generally be used when the soil moisture content does not exceed approximately 20 percent. If the soil moisture content is in the range of 20 to 35 percent, 5 to 7 percent by weight of dry soil is

recommended. The amount of cement added to the soil should be adjusted based on field observations and performance.

PCC-amended soil is hard and has low permeability; therefore, this soil does not drain well nor is it suitable for planting. Future landscape areas should not be cement amended, if practical, or accommodations should be planned for drainage and planting. Cement amendment should not be used if runoff during construction cannot be directed away from adjacent low-lying wet areas and active waterways and drainage paths.

When used for constructing pavement, staging or haul road subgrades, the amended surface should be protected from abrasion by placing a minimum 4-inch thickness of base rock material (Aggregate Base/Aggregate Subbase). To prevent strength loss during curing, cement-amended soil should be allowed to cure for a minimum of 4 days prior to placing the base rock. The base rock typically becomes contaminated with soil during construction. Contaminated base rock should be removed and replaced with clean base rock in pavement areas to meet the required thickness(es) in Section 8.0 Pavement Recommendations of this report.

It is not possible to amend soil during heavy or continuous rainfall. Work should be completed during suitable weather conditions.

6.5. Shoring and Temporary Slopes

All excavations should be made in accordance with applicable Occupational Safety and Health Administration (OSHA) and state regulations. Site soils within expected excavation depths typically range from very soft to medium stiff clay or silt, or medium dense gravel and sand fill. In our opinion, fine-grained native soils are generally OSHA Type B (OSHA 2018) and sandy native soils are Type C, provided there is no seepage and excavations occur during periods of dry weather. Excavations deeper than 4 feet should be shored or laid back at an inclination of 1H:1V for Type B soils and 1½H:1V for Type C soils. Flatter slopes may be necessary if workers are required to enter. Excavations made to construct footings or other structural elements should be laid back or shored at the surface as necessary to prevent soil from falling into excavations.

Temporary cut slopes should not exceed a gradient appropriate for the soil type being excavated. However, because of the variables involved, actual slope angles required for stability in temporary cut areas can only be estimated before construction. The stability and safety of cut slopes depend on a number of factors, including:

- The type and density of the soil.
- The presence and amount of any seepage.
- Depth of cut.
- Proximity and magnitude of the cut to any surcharge loads, such as stockpiled material, traffic loads or structures.
- Duration of the open excavation.
- Care and methods used by the contractor.

We recommend that stability of the temporary slopes used for construction be the responsibility of the contractor, since the contractor is in control of the construction operation and is continuously at the site to observe the nature and condition of the subsurface. If groundwater seepage is encountered within the excavation slopes, the cut slope inclination may have to be flatter than 1.5H:1V. However, appropriate inclinations will ultimately depend on the actual soil and groundwater seepage conditions exposed in the cuts at the time of construction. It is the responsibility of the contractor to ensure that the excavation is properly sloped or braced for worker protection, in accordance with applicable guidelines. To assist with this effort, we make the following recommendations regarding temporary excavation slopes:

- Protect the slope from erosion with plastic sheeting for the duration of the excavation to minimize surface erosion and raveling.
- Limit the maximum duration of the open excavation to the shortest time period possible.
- Place no surcharge loads (equipment, materials, etc.) within 10 feet of the top of the slope.

More restrictive requirements may apply depending on specific site conditions, which should be continuously assessed by the contractor.

If temporary sloping is not feasible based on site spatial constraints, excavations could be supported by internally braced shoring systems, such as a trench box or other temporary shoring. There are a variety of options available. We recommend that the contractor be responsible for selecting the type of shoring system to apply.

Additionally, in our opinion, the contractor will be in the best position to observe subsurface conditions continuously throughout the construction process and to respond to the soil and groundwater conditions. Construction site safety is generally the sole responsibility of the contractor, who also is solely responsible for the means, methods and sequencing of the construction operations and choices regarding excavations and shoring. Under no circumstances should the information provided by GeoEngineers be interpreted to mean that GeoEngineers is assuming responsibility for construction site safety or the contractor's activities; such responsibility is not being implied and should not be inferred.

6.6. Permanent Slopes

Permanent cut or fill slopes should not exceed a gradient of 2H:1V. Where access for landscape maintenance is desired, we recommend a maximum gradient of 3H:1V. Fill slopes should be overbuilt by at least 12 inches and trimmed back to the required slope to maintain a firm face.

To reduce erosion, newly constructed slopes should be planted or hydroseeded shortly after completion of grading. Until the vegetation is established, some sloughing and raveling of the slopes should be expected. This may necessitate localized repairs and reseeded. Temporary covering, such as clear heavy plastic sheeting, jute fabric or erosion control blankets (such as American Excelsior Curlex 1 or North American Green SC150) could be used to protect the slopes during periods of rainfall.

6.7. Dewatering

As discussed in Section 3.3.2 Groundwater Conditions of this report, groundwater was encountered in our explorations, but is expected to typically be below the anticipated excavation depths. Excavations that extend into saturated/wet soils should be dewatered. Sump pumps are expected to adequately address

groundwater encountered in shallow excavations. In addition to groundwater seepage and upward confining flow, surface water inflow to the excavations during the wet season can be problematic. Provisions for surface water control during earthwork and excavations should be included in the project plans and should be installed prior to commencing earthwork.

Deep wells or well points will likely be necessary where excavations extend below the groundwater table. The contractor should be required to submit a dewatering plan prepared by a registered professional engineer or hydrogeologist for review by the project team including GeoEngineers. Additionally, it should be noted that dewatering near the existing structure using wells or well points could result in settlement in addition to the long-term static settlement estimates presented in Section 7.3 Foundation Support Alternatives.

6.8. Structural Fill and Backfill

6.8.1. General

Materials used to support building foundations, floor slabs, hardscape, pavements and any other areas intended to support structures or within the influence zone of structures are classified as structural fill for the purposes of this report.

All structural fill soils should be free of debris, clay balls, roots, organic matter, frozen soil, man-made contaminants, particles with greatest dimension exceeding 4 inches and other deleterious materials. The suitability of soil for use as structural fill will depend on the gradation and moisture content of the soil. As the amount of fines in the soil matrix increases, the soil becomes increasingly more sensitive to small changes in moisture content and achieving the required degree of compaction becomes more difficult or impossible. Recommendations for suitable fill material are provided in the following sections.

6.8.2. Use of On-site Soil

As discussed in Section 3.3 Subsurface Conditions, on-site near surface soil generally consists of native silt and granular fill. On-site soils can be used as structural fill, provided the material meets the above requirements, although due to moisture sensitivity it could be challenging or impossible to use during periods of wet weather. If the soil is too wet to achieve satisfactory compaction, moisture-conditioning by drying back the material will be required. If the material cannot be properly moisture-conditioned, we recommend using imported material for structural fill.

An experienced geotechnical engineer from GeoEngineers should determine the suitability of on-site soil encountered during earthwork activities for reuse as structural fill.

6.8.3. Imported Select Structural Fill

Imported Select granular material may be used as structural fill. The imported material should consist of pit or quarry run rock, crushed rock or crushed gravel and sand that is fairly well-graded between coarse and fine sizes (approximately 25 to 65 percent passing the U.S. No. 4 sieve). It should have less than 5 percent passing the U.S. No. 200 sieve. During dry weather, the fines content can be increased to a maximum of 12 percent.

6.8.4. Aggregate Base

Aggregate base material located under floor slabs and crushed rock used in footing overexcavations should consist of imported clean, durable, crushed angular rock. Such rock should be well-graded, have a

maximum particle size of 1-inch and have less than 5 percent passing the U.S. No. 200 sieve (3 percent for retaining walls). In addition, aggregate base shall have a minimum of 75 percent fractured particles according to American Association of State Highway and Transportation Officials (AASHTO) TP-61 and a sand equivalent of not less than 30 percent based on AASHTO T-176.

6.8.5. Aggregate Leveling Course

Aggregate leveling coarse material located under Portland cement concrete (PCC) pavement sections should consist crushed rock used in footing overexcavations should consist of imported clean, durable, crushed angular rock. Such rock should be well-graded, have a maximum particle size of $\frac{3}{4}$ -inch and have less than 5 percent passing the U.S. No. 200 sieve (3 percent for retaining walls). In addition, aggregate leveling course shall have a minimum of 75 percent fractured particles according to American Association of State Highway and Transportation Officials (AASHTO) TP-61 and a sand equivalent of not less than 30 percent based on AASHTO T-176.

6.8.6. Trench Backfill

Backfill for pipe bedding and in the pipe zone should consist of well-graded granular material with a maximum particle size of $\frac{3}{4}$ -inch and less than 5 percent passing the U.S. No. 200 sieve. The material should be free of organic matter and other deleterious materials. Further, the backfill should meet the pipe manufacturer's recommendations. Above the pipe zone, Imported Select Structural Fill may be used as described above.

6.9. Fill Placement and Compaction

Structural fill should be compacted at moisture contents that are within 3 percent of the optimum moisture content as determined by ASTM International (ASTM) Test Method D 1557 (Modified Proctor). The optimum moisture content varies with gradation and should be evaluated during construction. Fill material that is not near the optimum moisture content should be moisture-conditioned prior to compaction.

Fill and backfill material should be placed in uniform, horizontal lifts and compacted with appropriate equipment. The appropriate lift thickness will vary depending on the material and compaction equipment used. Fill material should be compacted in accordance with Table 2 below. It is the contractor's responsibility to select appropriate compaction equipment and place the material in lifts that are thin enough to meet these criteria. However, in no case should the loose lift thickness exceed 18 inches.

TABLE 2. COMPACTION CRITERIA

Fill Type	Compaction Requirements		
	Percent Maximum Dry Density Determined by ASTM Test Method D 1557 at ± 3% of Optimum Moisture		
	0 to 2 Feet Below Subgrade	> 2 Feet Below Subgrade	Pipe Zone
Fine-grained soils (non-expansive)	92	92	----
Imported Granular, maximum particle size < 1¼ inch	95	95	----
Imported Granular, maximum particle size 1¼ inch to 4 inches (3-inch maximum under building footprints)	n/a (proof-roll)	n/a (proof-roll)	----
Retaining Wall Backfill*	92	92	----
Nonstructural Zones	90	90	90
Trench Backfill	95	90	90

Notes:

* Measures should be taken to prevent overcompaction of the backfill behind retaining walls. We recommend placing the zone of backfill located within 5 feet of the wall in lifts not exceeding about 6 inches in loose thickness and compacting this zone with hand-operated equipment such as a vibrating plate compactor and a jumping jack.

A representative from GeoEngineers should evaluate compaction of each lift of fill. Compaction should be evaluated by compaction testing unless other methods are proposed for oversized materials and are approved by GeoEngineers during construction. These other methods typically involve procedural placement and compaction specifications together with verifying requirements such as proof-rolling.

7.0 STRUCTURAL DESIGN RECOMMENDATIONS

7.1. Six-Story Mixed use Residential/Commercial Structures (Blocks 1 through 4)

We understand development will consist of a five-story wood-framed structure over a one-story concrete podium. Blocks 3 and 4 in the initial phase will also include a one-story below grade parking level that will extend beneath the concrete podium and under Block 5. Blocks 1 and 2 are proposed for similar development but it was not confirmed at the time of this report if the below-grade parking level would also be included.

Based on information provided to us by F40ELICH Engineers (Structural Engineer), we understand that column loads will be on the order of up to 575 kips; wall loads will be on the order of up to 10 klf; and floor loads on the order of 250 psf or less. We have developed our recommendations based on the design loads provided.

As a result of the anticipated loads, we estimate that static consolidation settlement of site soils overlying the competent dense to very dense gravel (absent ground improvement or rigid inclusions) could be up to 2.5- to 3.5-inches total with half that magnitude occurring as differential settlement over a horizontal distance of 50 feet.

To limit potential post-construction settlement, we recommend that proposed building loads be supported on spread footings over subgrade improved with ground improvements such as compacted aggregate piers or rigid inclusions, on spread footings founded directly on the underlying competent gravels or compacted crushed rock fill over the dense gravels, or on extended-depth pile type foundations where it may not be economically feasible to excavate to the competent gravel bearing layer.

7.2. Parking Structure (Block 5)

Block 5 is proposed to be occupied by a concrete parking structure comprising up to three stories above grade, and one below grade along the south margin of the site. Based on information provided by F4OELICH Engineers, column loads on the order of 534 kips; wall loads on the order of 10.2 kips, and floor loads of up to 250 psf are anticipated.

Based on our discussions with the project team, we anticipate that Block 5 may be constructed with zero offset from the southwest corner property line near an approximately 20-foot-tall gabion wall along Mill Creek and on the bank of the Willamette River. As detailed in the Geologic Hazard Assessment included in Appendix B, the existing wall has at least one broken (compromised) face section and is currently considered as marginally stable as a result of foundation undermining. The wall will require repair if block 5 is offset from top of the wall as discussed below, or removal/reconstruction or structural encasement if block 5 is extended to the edge of the property (i.e., zero offset). Suitable foundation options for block 5 depend on the preferred plan for the existing wall, but may include the following:

- If the existing wall is left in place and repaired, block 5 may be satisfactorily founded on shallow spread footing foundations over ground improvements such as CAPs, rigid inclusions or other ground improvements to support proposed building loads, provided that ground improvement and foundations can be designed such that they do not impose additional vertical or lateral load on the existing gabion wall after repair. Additionally, a scour analysis may be necessary as part of construction at the zero offset line to determine if additional setback from the stream and river adjacent slope should be considered so that new footings are not subject to instability as a result of scour.
- If the construction of block 5 with zero offset precludes the methods above, it may be satisfactorily founded on extended-depth foundations, or spread footings over CAPs that extend into the competent Linn Gravels or sufficiently deep such that the foundation system **can be designed so that no additional load is imposed vertically or horizontally** on the existing wall if it is to remain in place or rebuilt.

7.2.1.1. Block 5 Construction Considerations

Based on discussions with the project team, and assuming zero-offset of block 5, construction of an additional temporary or permanent wall along the face of the existing gabion wall would be necessary. If a new wall is constructed at the property boundary, the gabion wall could be removed or encased. Furthermore, the new wall could be incorporated into the exterior foundations of block 5 as a permanent below grade wall.

New foundations or permanent walls along Mill Creek should not be founded within a potential zone of scour. If project development includes constructing a permanent wall along Mill Creek to transfer structural loads to the underlying Linn Gravels, the wall should be designed for the at-rest earth pressures presented in Section 7.10 Retaining Walls of this report since it would be restrained against rotation by the structure,

and should also account for additional loading that may be transferred to the back of the wall from foundation and floor loads.

7.3. Foundation Support Alternatives

7.3.1. Shallow Foundations on Linn Gravels

It is our opinion that the underlying dense to very dense gravels are suitable for shallow foundation support. However, because of the increasing depth from south to north to the competent bearing gravels across the site, it will likely be more economically feasible to support proposed building loads on spread footings over subgrade improved with ground improvements, or to found buildings on extended-depth foundations where the competent gravels are not readily exposed at more shallow depths of excavation depths during construction.

7.3.1.1. Bearing Capacity – Spread Footings on Linn Gravels

We recommend that new conventional footings be proportioned using a maximum allowable bearing pressure of 4,000 psf if supported on the underlying dense to very dense gravel or structural fill bearing on these materials. The recommended bearing pressure applies to the total of dead and long-term live loads and may be increased by one-third when considering earthquake or wind loads. This is a net bearing pressure. The weight of the footing and overlying backfill can be ignored in calculating footing sizes.

7.3.1.2. Foundation Settlement – Spread Footings on Linn Gravels

Assuming that subgrade is prepared in accordance with Section 7.5 Shallow Foundation Subgrade Preparation of this report, foundations designed and constructed on the underlying dense to very dense gravels as recommended are expected to experience total static settlements of less than 1-inch. Static differential settlements of up to one-half of the total settlement magnitude can be expected between adjacent footings supporting comparable loads.

7.3.2. Ground Improvement/Aggregate Piers

Shallow spread and continuous footings supported on CAPs or rigid inclusions can provide higher bearing capacity and reduce total and differential settlement under design loads by creating a stiffened soil matrix subgrade. Ground improvement methods typically considered in the region include rammed aggregate piers (RAP) or Geopiers, and rigid inclusion systems designed and constructed by specialty foundation construction companies. Other ground improvement systems/contractors may be considered, but should be reviewed and approved by the project team.

CAP or rigid inclusion systems are typically designed and constructed by the specialty contractor to a performance specification. In our experience they typically range from 18- to 30-inch-diameter piers spaced in a triangular distribution with center-to-center spacing ranging from 6 to 8 feet depending on design loads and tolerable settlement requirements. The specialty contractor should be given a copy of our geotechnical report and the opportunity to complete additional explorations if they choose. They should submit a ground improvement design that has been completed and stamped by a registered professional engineer with experience in such projects. We recommend the geotechnical engineer of record review the design on behalf of the Owner, although the specialty contractor will retain responsibility for the design and construction of the ground improvements to the specified performance criteria.

The underlying dense to very dense gravel of the Linn Gravel Formation was encountered at varying depths of approximately 4 to 24 feet bgs in our explorations. We anticipate that compacted aggregate piers would

extend from the bottom of shallow foundations to this very dense Linn Gravel Formation or to a minimum design depth required to meet allowable bearing capacity for design loads as well as settlement tolerances for the project. Granular pads beneath shallow foundations should be discussed with the specialty contractor if required as part of load transfer to the underlying ground improvement.

The length of compacted aggregate piers may vary across the site. Compacted aggregate piers should be designed to meet the final bearing capacity and settlement tolerance provided by the structural engineer. The specialty contractor would provide final design and in-house quality control for the piers. We recommend that GeoEngineers provide construction quality assurance for the Owner during the construction process.

Structural fill to raise site grades should be placed after construction of ground improvements to reduce the overall depth of installation since improvements are typically extended to ground surface during construction.

7.3.2.1. Aggregate Piers Bearing Capacity

Allowable design bearing capacity of the compacted aggregate pier/improved subgrade matrix would be determined by the specialty contractor and will be dependent on actual building loads and acceptable settlement magnitudes. We typically see a bearing capacity of approximately 4,000 to 6,000 psf in the soil/pier matrix for soils similar to those we observed at the site that have been improved with compacted aggregate piers.

7.3.2.2. Foundation Settlement

Settlement for shallow foundations supported on an aggregate pier improved subgrade, as described above, would depend on the specialty contractor's design. Typically, systems are designed to a performance specification that is normally on the order of approximately 1-inch. Differential settlements of up to half the total magnitude can be expected between individual footings.

7.3.3. Deep Foundations

Deep foundations can be considered as a suitable option to support foundations and to transfer structural loads to the underlying, competent gravels. In addition to building loads. We anticipate driven piles (open-ended pipe or H-pile sections) or drilled and cast-in-place piles will likely be the most efficient deep foundation methods for this site.

If deep foundations are the preferred foundation alternative, they should be designed to extend through the upper middle terrace and fill deposits encountered in our explorations to underlying dense coarse-grained deposits. The top of these relatively dense layers was encountered at depths of approximately 4 to 24 feet bgs in our explorations.

7.4. Shallow Foundation Recommendations

Where shallow foundations are planned for the project, exterior footings should be established at least 18 inches below the lowest adjacent grade. The recommended minimum footing depth is greater than the anticipated frost depth. Interior footings can be founded a minimum of 12 inches below the top of the floor slab. Isolated column and continuous wall footings should have minimum widths of 24 and 18 inches, respectively. We have assumed that the maximum isolated column loads will be on the order of 40 kips, wall loads will be 2 klf or less and floor loads for slabs on grade will be 100 psf or less for the proposed

development. If design loads exceed these values, we should be notified as our recommendations may need to be revised.

7.5. Shallow Foundation Subgrade Preparation

Exterior footings should be established at least 18 inches below the lowest adjacent grade. The recommended minimum footing depth is greater than the anticipated frost depth. Interior footings can be founded a minimum of 12 inches below the top of the floor slab. Isolated column and continuous wall footings should have minimum widths of 24 and 18 inches, respectively.

We recommend loose or disturbed soils resulting from foundation excavation be removed before placing reinforcing steel and concrete. Foundation bearing surfaces should not be exposed to standing water. If water infiltrates and pools in the excavation, the water, along with any disturbed soil, should be removed before placing reinforcing steel. A thin layer of crushed rock can be used to provide protection to the subgrade from weather and light foot traffic. Compaction should be performed as described in Section 6.6 Permanent Slopes.

We recommend a representative of the geotechnical engineer of record observe all foundation excavations before placing concrete forms and reinforcing steel to determine that bearing surfaces have been adequately prepared and the soil conditions are consistent with those observed during our explorations. Additionally, we recommend overexcavating and placing a minimum of 2-foot-thick granular bearing pad consisting of crushed rock, structural fill compacted in accordance with Section 6.3. Overexcavation should extend laterally 1-foot beyond the edges of footings.

7.6. Shallow Foundation Lateral Resistance

Lateral loads on footings can be resisted by passive earth pressures on the sides of footings and by friction on the bearing surface. We recommend that passive earth pressures be calculated using an equivalent fluid unit weight of 240 pcf for foundations confined by native medium stiff or stiffer silt and 350 pcf if confined by a minimum of 2 feet of imported granular fill.

We recommend using a friction coefficient of 0.35 for foundations placed on the native medium stiff or stiffer silt, or 0.50 for foundations placed on a minimum 2-foot thickness of compacted crushed rock. The passive earth pressure and friction components may be combined provided the passive component does not exceed $\frac{2}{3}$ of the total.

The passive earth pressure value is based on the assumptions that the adjacent grade is level and static groundwater remains below the base of the footing throughout the year. The top 1-foot of soil should be neglected when calculating passive lateral earth pressures unless the adjacent area is covered with pavement. The lateral resistance values include a safety factor of approximately 1.5.

7.7. Drainage

We recommend the ground surface be sloped away from the building at least 5 percent for a minimum distance of 10 feet measured perpendicular to the face of the wall in accordance with section 1804.4 of the 2018 International Building Code (IBC). All downspouts should be tightlined away from the building foundation areas and should also be discharged into a stormwater disposal system. Downspouts should not be connected to footing drains.

Although not required based on groundwater depths observed in our explorations, if perimeter footing drains are used for below-grade structural elements or crawlspaces, they should be installed at the base of the exterior footings. The perimeter footing drains should be provided with cleanouts and should consist of at least 4-inch-diameter perforated pipe placed on a 3-inch bed of and surrounded by 6 inches of drainage material enclosed in a non-woven geotextile such as Mirafi 140N (or approved equivalent) to prevent fine soil from migrating into the drain material. We recommend against using flexible tubing for footing drainpipes. The perimeter drains should be sloped to drain by gravity to a suitable discharge point, preferably a storm drain. We recommend that the cleanouts be covered and placed in flush-mounted utility boxes. Water collected in roof downspout lines must not be routed to the footing drain lines.

7.8. Slab on Grade Floors

7.8.1. Design Parameters

Satisfactory subgrade support for floor slabs of up to 250 psf can be obtained provided the floor slab subgrade is prepared as recommended in Section 6.0 Earthwork Recommendations of this report, including compaction of the upper exposed subgrade. Slabs should be reinforced according to their proposed use and per the structural engineer's recommendations. Load-bearing concrete slabs should be designed assuming a modulus of subgrade reaction (k) of 100 pci.

The intent of supporting on-grade slabs on a minimum 6-inch-thick compacted crushed rock base is that it acts as a capillary break and provides adequate subgrade support for slab design (develop the recommended modulus of subgrade reaction). The crushed rock base material should consist of Aggregate Base material as described in Section 6.8 Structural Fill and Backfill of this report. The material should be placed as recommended in Section 6.9 Fill Placement and Compaction. If dry slabs are required (e.g., where adhesives are used to anchor carpet or tile to the slab or for other moisture-sensitive situations), a waterproof liner may be placed as a vapor barrier below the slab. The vapor barrier should be selected by the structural engineer and should be accounted for in the design floor section and mix design selection for the concrete, to accommodate the effect of the vapor barrier on concrete slab curing.

We estimate that concrete slabs constructed as recommended will settle less than 1 inch for slabs over native soils (no ground improvement required).

7.9. Seismic Design

7.9.1. 2018 IBC Seismic Design Parameters

Parameters provided in Table 3 are based on the conditions encountered during our subsurface exploration program and the procedure and requirements outlined in the 2018 IBC and the 2019 OSSC Chapters 1 and 18. Per American Society of Civil Engineers (ASCE) 7-16 Section 11.4.8, a site specific response analysis is required for site class F sites, and a ground motion hazard analysis or site-specific response analysis is required to determine the design ground motions for structures on Site Class D and E sites with S_1 greater than or equal to 0.2g. For this project, the site is classified as site class C; therefore, in our opinion the provisions of 11.4.8 are not applicable. The parameters listed on Table 3 may be used to determine the design ground motions if the

TABLE 3. MAPPED 2018 IBC SEISMIC DESIGN PARAMETERS

Parameter	Recommended Value ¹
Site Class	C
Mapped Spectral Response Acceleration at Short Period (S_s)	0.828 g
Mapped Spectral Response Acceleration at 1 Second Period (S_1)	0.415 g
Site Modified Peak Ground Acceleration (PGA_M)	0.462 g
Site Amplification Factor at 0.2 second period (F_a)	1.2
Site Amplification Factor at 1.0 second period (F_v)	1.5
Design Spectral Acceleration at 0.2 second period (S_{DS})	0.663 g
Design Spectral Acceleration at 1.0 second period (S_{D1})	.415 g

Notes:

¹ Parameters developed based on Latitude 45.0935° and Longitude -123.389137° using the Applied Technology Council (ATC) Hazards online tool.

7.9.2. Liquefaction Potential

Liquefaction is a phenomenon caused by a rapid increase in pore water pressure that reduces the effective stress between soil particles to near zero. The excessive buildup of pore water pressure results in the sudden loss of shear strength in a soil. Granular soil, which relies on interparticle friction for strength, is susceptible to liquefaction until the excess pore pressures can dissipate. Sand boils and flows observed at the ground surface after an earthquake are the result of excess pore pressures dissipating upwards, carrying soil particles with the draining water. In general, loose, saturated sand soil with low silt and clay contents is the most susceptible to liquefaction. Low plasticity, silty sand may be moderately susceptible to liquefaction under relatively higher levels of ground shaking.

As discussed in Section 3.3.2 of this report, groundwater was encountered during our explorations at approximately 30 feet bgs. The site soils below the groundwater table are expected to include dense to very dense gravel and sand, that is not considered susceptible to liquefaction for the design earthquake event. Therefore, it is our opinion that the risk for liquefaction at the site is very low.

7.9.3. Lateral Spreading Potential

Lateral spreading related to seismic activity typically involves lateral displacement of large, surficial blocks of non-liquefied soil when a layer of underlying soil loses strength during seismic shaking. Lateral spreading usually develops in areas where sloping ground or large grade changes (including retaining walls) are present. Based on our understanding of the subsurface conditions at the site, it is our opinion the risk of lateral spreading impacting the site is low.

7.10. Retaining Walls

7.10.1. Drainage

Positive drainage is imperative behind retaining structures. This can be accomplished by providing a drainage zone behind the wall consisting of free-draining material and perforated pipes to collect and dispose of the water. The drainage material should consist of Aggregate Base having less than 3 percent

passing the U.S. No. 200 sieve. The wall drainage zone should extend horizontally at least 18 inches from the back of the wall.

A perforated smooth-walled rigid drainpipe having a minimum diameter of 4 inches should be placed at the bottom of the drainage zone along the entire length of the wall, with the pipe invert at or below the base of the wall footing. The drainpipes should discharge to a tightline leading to an appropriate collection and disposal system. An adequate number of cleanouts should be incorporated into the design of the drains to provide access for regular maintenance. Roof downspouts, perimeter drains or other types of drainage systems should not be connected to retaining wall drain systems.

7.10.2. Concrete Retaining Walls Design Parameters

Retaining structures free to rotate slightly around the base should be designed for active earth pressures using an equivalent fluid unit weight (efp) of 40 pcf when the ground surface extends level behind the wall equal to a distance of at least twice the height of the wall, and 65 pcf for an inclined slope of 2H:1V above the wall. For lesser slopes between flat and 2H:1V, the efp can be linearly interpolated between the recommended values. The efp value is based on the following assumptions.

- The walls will not be restrained against rotation when the backfill is placed.
- Walls are 12 feet or less in total wall support height.
- The backfill within 2 feet of the wall consists of free-draining granular materials.
- Grades above the top of the walls are no steeper than a 2H:1V slope.
- Total wall heights are determined based on a level front slope from the base of the wall.
- Hydrostatic pressures do not develop, and drainage will be provided behind the wall.

Seismically induced lateral forces on permanent below-grade building walls can be calculated using a dynamic force equal to $10.6H$ psf, where H is the wall height. This seismic force should be applied with the centroid located at $0.6H$ from the wall base. These values assume that the wall is vertical and unrestrained and the backfill behind the wall is horizontal.

For site retaining walls, seismic lateral earth pressures should be computed as a part of retaining wall design using the Mononobe-Okabe equation or another method appropriate to the selected wall system.

Retaining walls, including foundation walls that are restrained against rotation during backfilling, should be designed for an at-rest equivalent fluid unit weight of 64 pcf when the ground surface extends level behind the wall equal to a distance of at least twice the height of the wall, and 96 pcf for an inclined slope of 2H:1V above the wall. For lesser slopes between flat and 2H:1V, the efp can be linearly interpolated between the recommended values.

Surcharge loads applied closer than one-half of the wall height should be considered as uniformly distributed horizontal pressures equal to one-third of the distributed vertical surcharge pressure. Footings for retaining walls should be designed as recommended for shallow foundations. Backfill should be placed and compacted as recommended for structural fill.

Re-evaluation of our recommendations will be required if the retaining wall design criteria for the project vary from these assumptions.

We recommend that GeoEngineers be retained to review the retaining wall design to confirm that it meets the requirements in our report. The retaining wall designer should perform global stability analysis of the proposed wall.

8.0 PAVEMENT RECOMMENDATIONS

Our pavement recommendations are based on the results of our field testing and analysis. The recommended pavement sections assume that final improvements surrounding the pavement will be designed and constructed such that stormwater or excess irrigation water from landscape areas does not infiltrate below the pavement section into the base rock materials.

Standards used for pavement design for asphalt pavement design and adapted for gravel section design by deleting the upper AC section are listed below:

- *Oregon Department of Transportation (ODOT) Pavement Design Guide (ODOT 2019)*
- *AASHTO Guide for Design of Pavement Structures (AASHTO 1993).*
- Supplement to AASHTO 93 Part II Rigid Pavement Design & Rigid Pavement Joint Design.

8.1. Drainage

Long-term performance of pavements is influenced significantly by drainage conditions beneath the pavement section. Positive drainage can be accomplished by crowning the subgrade and establishing grades to promote drainage.

8.2. On-Site Asphalt Concrete (AC) Pavement Sections

Pavement subgrades should be prepared in accordance with Section 6.2 of this report. Our pavement recommendations assume that traffic at the site will consist of occasional truck traffic and passenger cars. We do not have specific information on the frequency and type of vehicles that will use the area; however, we have based our design analysis on traffic loading consistent with heavy trucks to account for delivery- and service-type vehicles and passenger car traffic for the heavy-duty pavement sections, and passenger car traffic only for the light-duty pavement sections and the assumed equivalent single axle loads (ESALS) presented in Table 4.

Our pavement recommendations are based on the following assumptions:

- The on-site soil subgrade below proposed fill placed to raise site grades or below aggregate base sections has been prepared as described in Section 6.2 Subgrade Preparation and Evaluation of this report, and observations indicate that subgrade is in a firm and unyielding condition.
- A resilient modulus of 20,000 psi was estimated for base rock prepared and compacted as recommended.

- A resilient modulus of 4,500 psi was estimated for firm in-place soils or structural fill placed on firm native soils for the proposed parking lot and drive aisles.
- Initial and terminal serviceability indices of 4.2 and 2.0, respectively.
- Reliability and standard deviations of 75 percent and 0.45, respectively.
- Structural coefficients of 0.41 and 0.10 for the asphalt and base rock, respectively.
- A 20-year design life.

If any of the noted assumptions vary from project design use, our office should be contacted with the appropriate information so that the pavement designs can be revised or confirmed adequate.

The recommended minimum pavement sections are provided in Table 4. Pavement recommendations for “On-Site Local Roads” are for roadways within the development only.

An alternate pavement section using Aggregate Subbase material is provided below because it may be more applicable during wet-weather construction where a gravel haul road or working surface is needed to support construction traffic. Wet weather construction recommendations are provided in Section 6.0 of this report. The subbase material can be incorporated into the gravel working blankets and haul roads provided the material meets the minimum thickness in Table 4 and meets the specifications for Aggregate Subbase. Working blanket and haul road materials that pump excessively, or have excessive fines from construction traffic, should be removed and replaced with specified materials prior to constructing roadways over those areas.

TABLE 4. MINIMUM ON-SITE PAVEMENT SECTION THICKNESS

Section	Minimum Asphalt Thickness (inches)	Minimum Aggregate Base Thickness (inches)	Minimum Aggregate Subbase Thickness (inches)	Assumed Traffic Loading (Design Life ESAL's)
Light Duty (general automobile parking areas)	2.5	10	-	<10,000
	2.5	4	12	
Heavy Duty (drive aisles and heavy delivery areas, or City designated local cul-de-sac)	3.5	10	-	<50,000
	3.5	4	12	

The recommended minimum pavement sections are provided in Table 4. Pavement recommendations for “On-Site Local Roads” are for roadways within the development only.

The aggregate base course should conform to Section 6.8.4 Aggregate Base of this report and be compacted to at least 95 percent of the maximum dry density (MDD) determined in accordance with AASHTO T-180/ASTM Test Method D 1557. The AC pavement should conform to Section 00745 of the most current edition of the *ODOT Standard Specifications for Highway Construction*. The Job Mix Formula should meet the requirements for a ½-inch Dense Graded Level 2 Mix. The AC should be PG 64-22 grade meeting the *ODOT Standard Specifications for Asphalt Materials*. AC pavement should be compacted to 92.0 percent at Maximum Theoretical Unit Weight (Rice Gravity) of AASHTO T-209.

If cement amendment is used during site development, as described in Section 6.0 of this report, it may be possible to reduce the amount of aggregate base for the pavement sections. This will depend on several factors, including the prevailing weather conditions, depth of amendment and condition of the subgrade after amendment. GeoEngineers can provide additional information for on-site pavement sections if cement amendment will be used during construction.

The recommended pavement sections assume that final improvements surrounding the pavement will be designed and constructed such that stormwater or excess irrigation water from landscape areas does not infiltrate below the pavement section into the crushed base.

TABLE 5. PAVEMENT SECTION RECOMMENDATIONS WITH CEMENT AMENDED SUB-BASE

Section	Minimum Asphalt Thickness (inches)	Minimum Aggregate Base Thickness (inches)	Minimum Cement Amended Subgrade Thickness (inches)
Light Duty (general automobile parking areas)	3.0	4.0	12
Heavy Duty (drive aisles and heavy delivery areas)	3.0	4.0	12

Cement amendment may be used during site development, as described above, or to reduce the pavement section thickness. The exact design of the amount of cement to be used should be determined based on the condition of the subgrade at the time of construction and the prevailing weather conditions but should likely be between 3 and 6 percent. We recommend the minimum thickness of amendment be 12 inches. GeoEngineers can provide additional information regarding cement volumes at the time of construction. The minimum pavement sections, with a 12-inch-thick cement amended soil section, are provided in Table 5 above.

8.3. Front Street NE

8.3.1. Existing Pavement Section

The existing pavement section thickness along Front Street NE was observed using ground penetrating radar (GPR) at locations GPR-1 through GPR-7 and with a cored location at boring location B-6 as shown on Figure 2. A summary of existing pavement section thickness at is presented in Table 6.

TABLE 6. EXISTING PAVEMENT SECTION

Exploration Designation	Approximate Asphalt Concrete thickness (Inches)	Approximate Base Course Thickness (Inches)
GPR-1	4	14
GPR-2	4	14
B-6/GPR-3	6	12
GPR-4	6	12
GPR-5	8	22
GPR-6	6	12

Exploration Designation	Approximate Asphalt Concrete thickness (Inches)	Approximate Base Course Thickness (Inches)
GPR-7	8	24

8.3.2. Asphalt Concrete Pavement Design

Project development includes widening Front Street NE to accommodate increased traffic in the area from the proposed development. Widening the roadway will involve raising the current grade to match the existing roadway elevation. Fill placement to raise subgrade elevations and pavement subgrades should be prepared in accordance with Section 6.2 of this report.

AC pavement recommendations for the widening of Front Street NE are provided in Table 7. The recommended pavement sections are provided in Table 7. If any of the noted assumptions vary from project design use, our office should be contacted with the appropriate information so that the pavement designs can be revised or confirmed adequate.

Our pavement recommendations are based on the following assumptions and design parameters included in the *ODOT Pavement Design Guide*:

- The pavement subgrades, fill subgrades and site earthwork used to establish road grades below the Aggregate Subbase and Aggregate Base materials have been prepared as described in Section 6.0 of this report.
- A resilient modulus of 20,000 psi has been estimated for compacted Aggregate Base.
- A resilient modulus of 4,500 psi was estimated for subgrade prepared and compacted as recommended.
- Initial and terminal serviceability indices of 4.2 and 2.5, respectively.
- Reliability and standard deviations of 90 percent and 0.49, respectively.
- Structural coefficients of 0.41 and 0.10 for the asphalt and base rock, respectively.
- A 25-year design life.
- Estimated traffic levels (4,000,000 ESAL's) based on City of Salem Administrative Rules Division 006 Default ESALS based on a Minor Arterial Classification.

TABLE 7. MINIMUM PAVEMENT SECTIONS FOR FRONT STREET NE WIDENING

Minimum Asphalt Thickness (inches)	Minimum Aggregate Base Thickness (inches)	Minimum Aggregate Subbase Thickness (inches)
7.0	21	0.0
7.0	16	12.0

The aggregate base course should conform to Section 6.8.4 of this report and be compacted to at least 95 percent of the MDD determined in accordance with AASHTO T-180/ASTM Test Method D 1557.

The AC pavement should conform to Section 00745 of the most current edition of the *ODOT Standard Specifications for Highway Construction*. The Job Mix Formula should meet the requirements for a ½-inch Dense Graded Level 3 Mix. The AC should be PG 70-22 grade meeting the *ODOT Standard Specifications for Asphalt Materials*. AC pavement should be compacted to 92.0 percent at Maximum Theoretical Unit Weight (Rice Gravity) of AASHTO T-209.

8.3.3. Portland Cement Concrete Pavement Design

PCC pavement section recommendations for the widening of Front Street NE are provided in Table 8 and based on the assumptions below. If any of the noted assumptions vary from project design use, our office should be contacted with the appropriate information so that the pavement designs can be revised or confirmed adequate.

Our pavement recommendations are based on the following assumptions and design parameters included in the ODOT Pavement Design Guide and City of Salem Administrative Rules Section 006:

- The pavement subgrades, fill subgrades and site earthwork used to establish road grades below the Aggregate Subbase and Aggregate Base materials have been prepared as described in Section 6.0 of this report.
- A modulus of subgrade reaction (k) of 150 psi was estimated for subgrade prepared and compacted as recommended.
- A concrete rupture modulus of 600 psi was estimated based on a 28-day compressive strength of concrete equal to 4500 psi.
- A drainage coefficient of 0.9 was estimated for site silty soils.
- A joint load coefficient of 3.2 was estimated for PCC reinforced using plain dowel bars.
- Initial and terminal serviceability indices of 4.2 and 2.5, respectively.
- Reliability and standard deviations of 90 percent and 0.49, respectively.
- A 50-year design life.
- Estimated traffic levels (4,000,000 ESAL’s) based on City of Salem Administrative Rules Division 006 Default ESALS based on a Minor Arterial Classification.

TABLE 8. MINIMUM PCC PAVEMENT SECTIONS FOR FRONT STREET NE WIDENING

Minimum Portland Cement Concrete Thickness (inches)	Minimum Leveling course Thickness (inches)
8.5	8

Joint spacing for PCC pavements should be designed in accordance with section 6.26(d) of the City of Salem Administrative Rules. Longitudinal spacing of joints should not exceed two times the slab thickness in feet up to a maximum distance of 15 feet.

The leveling course should conform to Section 6.8.5 Aggregate Leveling Course of this report and be compacted to at least 95 percent of the MDD determined in accordance with AASHTO T-180/ASTM Test Method D 1557.

9.0 DESIGN REVIEW AND CONSTRUCTION SERVICES

Recommendations provided in this report are based on the assumptions and preliminary design information stated herein. We welcome the opportunity to review and discuss construction plans and specifications for this project as they are being developed. In addition, GeoEngineers should be retained to review the geotechnical-related portions of the plans and specifications to evaluate whether they are in conformance with the recommendations provided in this report.

Satisfactory foundation and earthwork performance depends to a large degree on quality of construction. Sufficient monitoring of the contractor's activities is a key part of determining that the work is completed in accordance with the construction drawings and specifications. Subsurface conditions observed during construction should be compared with those encountered during the subsurface explorations. Recognition of changed conditions often requires experience; therefore, qualified personnel should visit the site with sufficient frequency to detect whether subsurface conditions change significantly from those anticipated.

We recommend that the geotechnical engineer of record be retained to observe construction at the site to confirm that subsurface conditions are consistent with the site explorations, and to confirm that the intent of project plans and specifications relating to earthwork, pavement and foundation construction are being met.

10.0 LIMITATIONS

We have prepared this report for the exclusive use of Future of Neighborhood Development, and their authorized agents and/or regulatory agencies for the proposed Salem Cannery 6-Story Mixed-use Development Project located along Front Street NE between Belmont Street NE and Shipping Street NE in Salem, Oregon.

This report is not intended for use by others, and the information contained herein is not applicable to other sites. No other party may rely on the product of our services unless we agree in advance and in writing to such reliance.

Within the limitations of scope, schedule and budget, our services have been executed in accordance with generally accepted practices in the area at the time this report was prepared. No warranty or other conditions, express or implied, should be understood.

Please refer to Appendix C, Report Limitations and Guidelines for Use for additional information pertaining to use of this report.

11.0 REFERENCES

American Association of State Highway and Transportation Officials (AASHTO). 1993. Guide for Design of Pavement Structures.

Bela, J.L. 1981. Geology of the Rickreall, Salem West, Monmouth, and Sidney 7 1/2-minute quadrangles, Marion, Polk, and Linn Counties, Oregon: Oregon Department of Geology and Mineral Industries Geological Map Series GMS-18, 2 plates, 1:24,000 scale.

Department of Geology and Mineral Industries (DOGAMI). 2022. DOGAMI web based Statewide Landslide Information Layer for Oregon (including LiDAR viewer) accessed on October 25, 2022 at <https://gis.dogami.oregon.gov/maps/slido>.

International Code Council. 2018. 2018 International Building Code.

International Code Council. 2019. 2019 Oregon Structural Specialty Code.

Occupational Safety and Health Administration (OSHA). Technical Manual Section V: Chapter 2, Excavations: Hazard Recognition in Trenching and Shoring: http://www.osha.gov/dts/osta/otm/otm_v/otm_v_2.html.

Oregon Department of Transportation (ODOT). 2021. Oregon Standard Specifications for Construction, Oregon Department of Transportation.

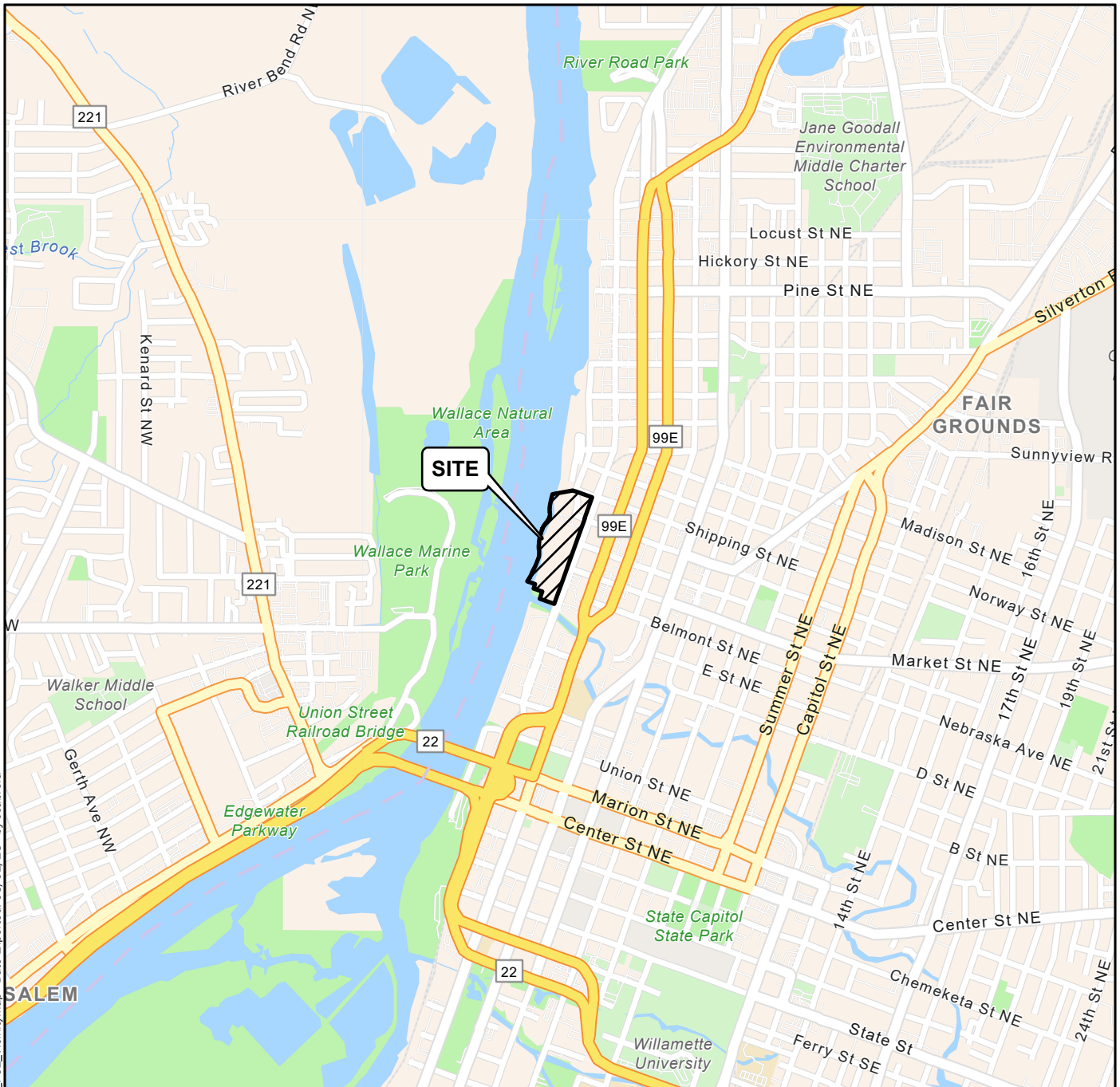

P:\26\26595001\GIS\26595001_Project.aprx\26595001_F01_VicinityMap Date Exported: 03/02/23 by ccabrera

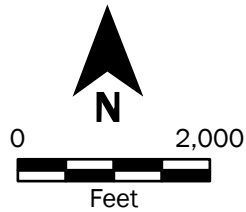
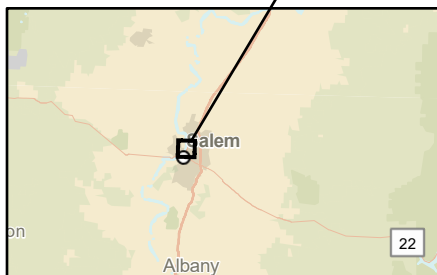

Source(s):
• ESRI





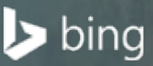

Coordinate System: NAD 1983 UTM Zone 10N

Disclaimer: This figure was created for a specific purpose and project. Any use of this figure for any other project or purpose shall be at the user's sole risk and without liability to GeoEngineers. The locations of features shown may be approximate. GeoEngineers makes no warranty or representation as to the accuracy, completeness, or suitability of the figure, or data contained therein. The file containing this figure is a copy of a master document, the original of which is retained by GeoEngineers and is the official document of record.

Vicinity Map	
Salem Cannery 6-story Mixed-use Development Salem, Oregon	
	Figure 1





Legend

-  Boring Number and Approximate Location
-  Boring/IT Number and Approximate Location
-  Boring/GPR Number and Approximate Location
-  CPT Number and Approximate Location
-  GPR Number and Approximate Location
-  Cross Section

Source(s):
 • Marion County roads

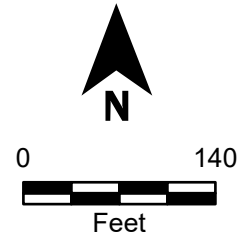
Coordinate System: NAD 1983 HARN StatePlane Oregon North FIPS 3601 Feet Intl
Disclaimer: This figure was created for a specific purpose and project. Any use of this figure for any other project or purpose shall be at the user's sole risk and without liability to GeoEngineers. The locations of features shown may be approximate. GeoEngineers makes no warranty or representation as to the accuracy, completeness, or suitability of the figure, or data contained therein. The file containing this figure is a copy of a master document, the original of which is retained by GeoEngineers and is the official document of record.



Site Plan	
Salem Cannery 6-story Mixed-use Development Salem, Oregon	
	Figure 2

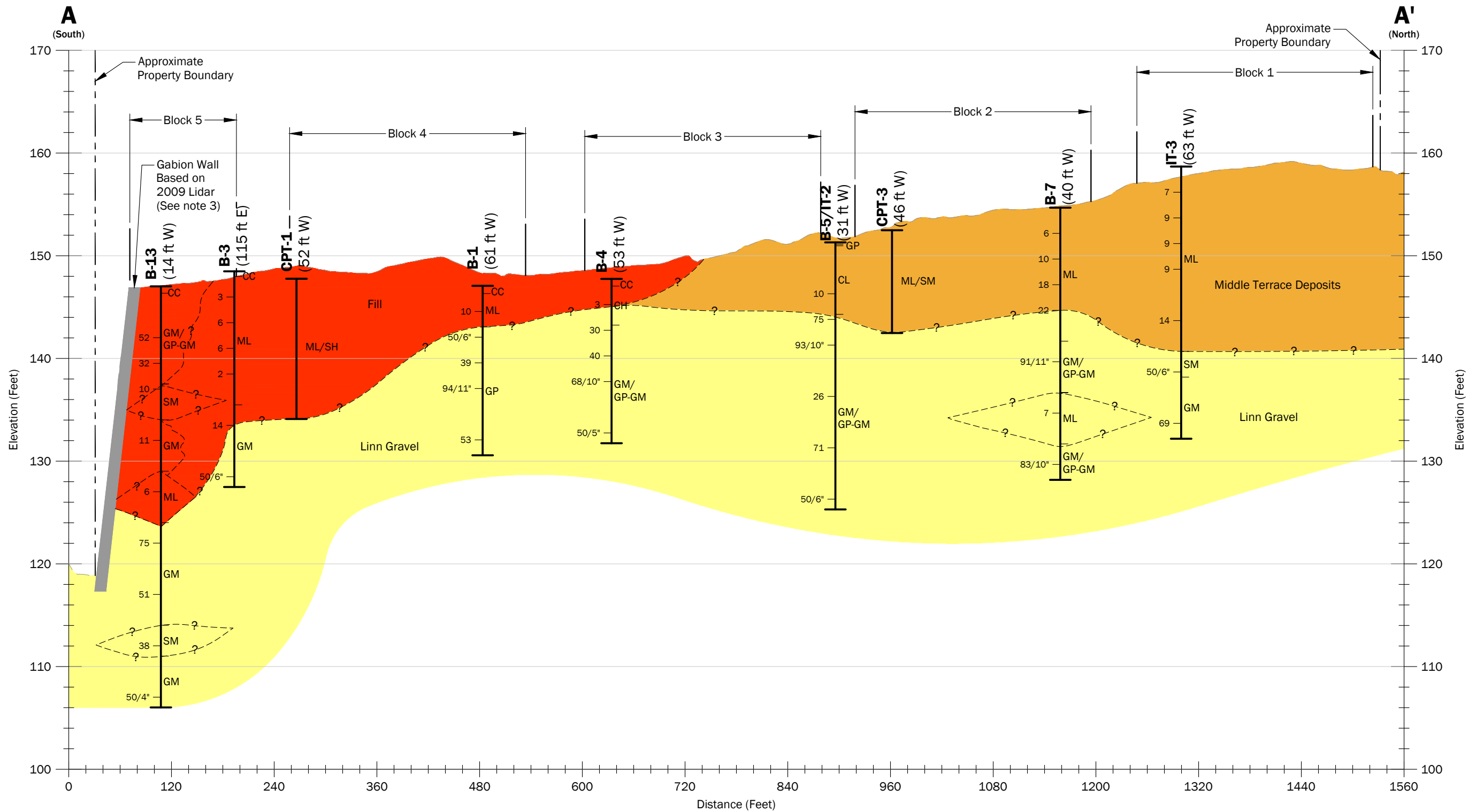

Notes:

1. The subsurface conditions shown are based on interpolation between widely spaced explorations and should be considered approximate; actual subsurface conditions may vary from those shown.
2. This figure is for informational purposes only. It is intended to assist in the identification of features discussed in a related document. Data were compiled from sources as listed in this figure. The data sources do not guarantee these data are accurate or complete. There may have been updates to the data since the publication of this figure. This figure is a copy of a master document. The hard copy is stored by GeoEngineers, Inc. and will serve as the official document of record.
3. Gabion wall failed between August 2022 and March 16, 2023 (Based on aerial photo review and site observation). Therefore the topography shown in the vicinity of the Gabion Wall is not accurate

Data Source: Lidar from Oregon Department of Geology and Mineral Industries Lidar Data Quadrangle Series Collected in 2009.

Datum: NAVD 88, unless otherwise noted.

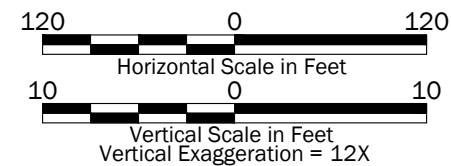
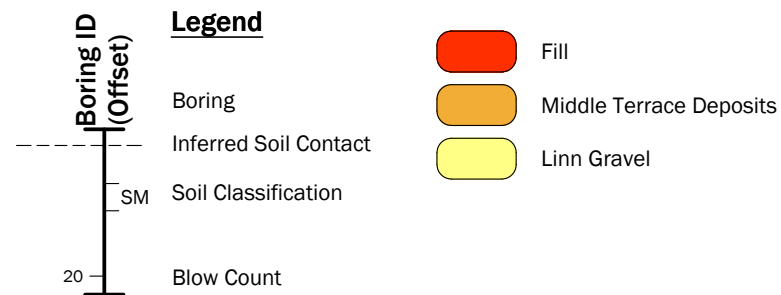

Cross Section A-A'	
Salem Cannery 6-story Mixed-use Development Salem, Oregon	
	Figure 3

APPENDIX A
Field Explorations and Laboratory Testing

APPENDIX A

FIELD EXPLORATIONS AND LABORATORY TESTING

Field Explorations

Soil and groundwater conditions at the site were explored between February 20 and February 25, 2023, by completing 13 drilled borings (B-1 to B-13), 3 infiltration tests, 6 ground penetration radar (GPR) soundings and 4 cone penetration tests (CPT's) at the approximate locations shown on Figure 2, Site Plan. The drilled borings were advanced using a track-mounted drill rig owned and operated by Western States Soil Conservation Inc. and the CPT's were advanced using a truck-mounted rig owned and operated by Oregon Geotechnical Explorations.

The borings were continuously monitored by a qualified staff from our office who maintained detailed logs of subsurface explorations, visually classified the soil encountered and obtained representative soil samples from the borings. Representative soil samples were obtained from each boring at approximate 2½-foot-depth intervals using a 1-inch, inside-diameter, standard split spoon sampler. The samplers were driven into the soil using a 140-pound hammer, free-falling 30 inches on each blow. The number of blows required to drive the sampler each of three, 6-inch increments of penetration were recorded in the field. The sum of the blow counts for the last two, 6-inch increments of penetration is reported on the boring logs as the ASTM International (ASTM) Test Method D 1556 Standard Penetration Test (SPT) N-value.

Recovered soil samples were visually classified in the field in general accordance with ASTM D 2488 and the classification chart listed in Figure A-1, Key to Exploration Logs. Logs of the borings are presented in Figures A-2 through A-14, Logs of Drilled Borings. Logs of the CPTs are presented in Figures A-15 through A-18, Logs of CPT Soundings. The logs are based on interpretation of the field and laboratory data and indicate the depth at which subsurface materials, or their characteristics change, although these changes might actually be gradual.

Laboratory Testing

Soil samples obtained from the explorations were visually classified in the field and in our laboratory using the Unified Soil Classification System (USCS) and ASTM classification methods. ASTM Test Method D 2488 was used to visually classify the soil samples. A discussion relating to the laboratory tests performed is provided below.

Moisture Content

Moisture content tests were completed in general accordance with ASTM D 2216 for representative samples obtained from the explorations. The results of these tests are presented on the exploration logs in Appendix A at the depths at which the samples were obtained.

Atterberg Limits Testing

Atterberg limits testing was performed on selected fine-grained soil samples. The tests were used to classify the soil as well as to evaluate index properties. The liquid limit and the plastic limit were estimated through a procedure performed in general accordance with ASTM D 4318. The results of the Atterberg limits testing are summarized in Figure A-19, Atterberg Limits Test Results.

SOIL CLASSIFICATION CHART

MAJOR DIVISIONS			SYMBOLS		TYPICAL DESCRIPTIONS
			GRAPH	LETTER	
COARSE GRAINED SOILS	GRAVEL AND GRAVELLY SOILS	CLEAN GRAVELS <small>(LITTLE OR NO FINES)</small>		GW	WELL-GRADED GRAVELS, GRAVEL - SAND MIXTURES
		GRAVELS WITH FINES <small>(APPRECIABLE AMOUNT OF FINES)</small>		GP	POORLY-GRADED GRAVELS, GRAVEL - SAND MIXTURES
		SANDS WITH FINES <small>(APPRECIABLE AMOUNT OF FINES)</small>		GM	SILTY GRAVELS, GRAVEL - SAND - SILT MIXTURES
	SAND AND SANDY SOILS	CLEAN SANDS <small>(LITTLE OR NO FINES)</small>		SW	WELL-GRADED SANDS, GRAVELLY SANDS
		SANDS WITH FINES <small>(APPRECIABLE AMOUNT OF FINES)</small>		SP	POORLY-GRADED SANDS, GRAVELLY SAND
		SANDS WITH FINES <small>(APPRECIABLE AMOUNT OF FINES)</small>		SM	SILTY SANDS, SAND - SILT MIXTURES
FINE GRAINED SOILS	SILTS AND CLAYS	LIQUID LIMIT LESS THAN 50		ML	INORGANIC SILTS, ROCK FLOUR, CLAYEY SILTS WITH SLIGHT PLASTICITY
		LIQUID LIMIT LESS THAN 50		CL	INORGANIC CLAYS OF LOW TO MEDIUM PLASTICITY, GRAVELLY CLAYS, SANDY CLAYS, SILTY CLAYS, LEAN CLAYS
		LIQUID LIMIT LESS THAN 50		OL	ORGANIC SILTS AND ORGANIC SILTY CLAYS OF LOW PLASTICITY
	SILTS AND CLAYS	LIQUID LIMIT GREATER THAN 50		MH	INORGANIC SILTS, MICACEOUS OR DIATOMACEOUS SILTY SOILS
		LIQUID LIMIT GREATER THAN 50		CH	INORGANIC CLAYS OF HIGH PLASTICITY
		LIQUID LIMIT GREATER THAN 50		OH	ORGANIC CLAYS AND SILTS OF MEDIUM TO HIGH PLASTICITY
HIGHLY ORGANIC SOILS			PT	PEAT, HUMUS, SWAMP SOILS WITH HIGH ORGANIC CONTENTS	

NOTE: Multiple symbols are used to indicate borderline or dual soil classifications

Sampler Symbol Descriptions

	2.4-inch I.D. split barrel / Dames & Moore (D&M)
	Standard Penetration Test (SPT)
	Shelby tube
	Piston
	Direct-Push
	Bulk or grab
	Continuous Coring

Blowcount is recorded for driven samplers as the number of blows required to advance sampler 12 inches (or distance noted). See exploration log for hammer weight and drop.

"P" indicates sampler pushed using the weight of the drill rig.

"WOH" indicates sampler pushed using the weight of the hammer.

NOTE: The reader must refer to the discussion in the report text and the logs of explorations for a proper understanding of subsurface conditions. Descriptions on the logs apply only at the specific exploration locations and at the time the explorations were made; they are not warranted to be representative of subsurface conditions at other locations or times.

ADDITIONAL MATERIAL SYMBOLS

SYMBOLS		TYPICAL DESCRIPTIONS
GRAPH	LETTER	
	AC	Asphalt Concrete
	CC	Cement Concrete
	CR	Crushed Rock/ Quarry Spalls
	SOD	Sod/Forest Duff
	TS	Topsoil

Groundwater Contact



Measured groundwater level in exploration, well, or piezometer



Measured free product in well or piezometer

Graphic Log Contact

Distinct contact between soil strata

Approximate contact between soil strata

Material Description Contact

Contact between geologic units

Contact between soil of the same geologic unit

Laboratory / Field Tests

%F	Percent fines
%G	Percent gravel
AL	Atterberg limits
CA	Chemical analysis
CP	Laboratory compaction test
CS	Consolidation test
DD	Dry density
DS	Direct shear
HA	Hydrometer analysis
MC	Moisture content
MD	Moisture content and dry density
Mohs	Mohs hardness scale
OC	Organic content
PM	Permeability or hydraulic conductivity
PI	Plasticity index
PL	Point load test
PP	Pocket penetrometer
SA	Sieve analysis
TX	Triaxial compression
UC	Unconfined compression
UU	Unconsolidated undrained triaxial compression
VS	Vane shear

Sheen Classification

NS	No Visible Sheen
SS	Slight Sheen
MS	Moderate Sheen
HS	Heavy Sheen

Key to Exploration Logs

Start Drilled	2/20/2023	End	2/20/2023	Total Depth (ft)	16.5	Logged By	SLG	Checked By		Driller	Western States Soil Conservation	Drilling Method	Hollow-stem Auger
Surface Elevation (ft) Vertical Datum	147 NAVD88			Hammer Data	Autohammer 140 (lbs) / 30 (in) Drop			Drilling Equipment	CME 850				
Easting (X) Northing (Y)	7545339 479024			System Datum	OR State Plane NAD83 (feet)			Groundwater not observed at time of exploration					
Notes:													

Elevation (feet)	FIELD DATA					Graphic Log	Group Classification	MATERIAL DESCRIPTION	Moisture Content (%)	Fines Content (%)	REMARKS
	Depth (feet)	Interval Recovered (in)	Blows/foot	Collected Sample	Sample Name Testing						
0						CC	Approximately 9 inches cement concrete pavement				
1.45						ML	Dark brown silt with occasional gravel (stiff to very stiff, moist) (fill)	19			
	6	10		1 MC		GP	Brown silty sandy gravel with sand interbeds (very dense, moist) (Linn gravels)				
5	6	50/6"		2			Becomes dense				
1.40	12	39		3			Becomes very dense				
10	12	94/11"		4							
1.35											
15	12	53		5							

Date: 3/23/23 Path: P:\26_26595001\GINT_2659500100.gpj DBLibrary\Library\GEOENGINEERS_DF_STD_US_JUNE_2017.GLB\GEBB_GEOTECH_STANDARD_%F_NO_GW

Note: See Figure A-1 for explanation of symbols.
Coordinates Data Source: Horizontal approximated based on Aerial Imagery. Vertical approximated based on Aerial Imagery.

Log of Boring B-1



Project: Salem Cannery 6 Story Mixed-use Development
Project Location: Salem, Oregon
Project Number: 26595-001-00

Drilled	Start 2/25/2023	End 2/25/2023	Total Depth (ft)	30.75	Logged By Checked By	JLL	Driller	Western States Soil Conservation	Drilling Method	Hollow-stem Auger
Surface Elevation (ft) Vertical Datum	149 NAVD88			Hammer Data	Autohammer 140 (lbs) / 30 (in) Drop			Drilling Equipment	CME 850	
Easting (X) Northing (Y)	7545550 478991			System Datum	OR State Plane NAD83 (feet)			Groundwater not observed at time of exploration		
Notes:										

Elevation (feet)	Depth (feet)	FIELD DATA			Graphic Log	Group Classification	MATERIAL DESCRIPTION	Moisture Content (%)	Fines Content (%)	REMARKS
		Interval Recovered (in)	Blows/foot	Collected Sample						
0					GM	Gray-brown silty gravel with sand (loose, moist) (fill)				
1.45		6	4							
5		10	44		GP-GM	Gray-brown gravel with silt and sand (dense, moist)				
1.40		10	7		SM	Gray-brown silty fine to medium sand with occasional gavel (loose, moist to wet)				
10		14	51		GP-GM	Brown gravel with silt and sand (dense, moist) (Linn gravels)				
1.35		6	50/6"							
1.30		6	50/5"							
20		6	50/5"							
1.25		9	24		GM	Brown silty gravel with sand (medium dense, moist to wet)				
25		9	24							
1.20		6	50/3"		GP-GM	Brown gravel with silt and sand (very dense, moist)				
30		6	50/3"							

Note: See Figure A-1 for explanation of symbols.
Coordinates Data Source: Horizontal approximated based on Aerial Imagery. Vertical approximated based on Aerial Imagery.

Log of Boring B-2



Project: Salem Cannery 6 Story Mixed-use Development
Project Location: Salem, Oregon
Project Number: 26595-001-00

Date: 3/23/23 Path: P:\26_26595001\GINT_2659500100.GPJ DBLibrary\Library\GEOENGINEERS_DF_STD_US_JUNE_2017.GLB\GERB_GEOTECH_STANDARD_%F_NO_GW

Start Drilled	2/20/2023	End	2/20/2023	Total Depth (ft)	21	Logged By	SLG	Checked By		Driller	Western States Soil Conservation	Drilling Method	Hollow-stem Auger
Surface Elevation (ft) Vertical Datum	148 NAVD88			Hammer Data	Autohammer 140 (lbs) / 30 (in) Drop			Drilling Equipment		CME 850			
Easting (X) Northing (Y)	7545397 478689			System Datum	OR State Plane NAD83 (feet)			Groundwater not observed at time of exploration					
Notes:													

Elevation (feet)	Depth (feet)	FIELD DATA				Graphic Log	Group Classification	MATERIAL DESCRIPTION	Moisture Content (%)	Fines Content (%)	REMARKS
		Interval Recovered (in)	Blows/foot	Collected Sample	Sample Name Testing						
0						CC	Approximately 6 inches cement concrete pavement				
						ML	Brown silt (soft, moist) (fill)				
145	4	4	3					31		AL (LL = 38, PI = 18)	
	5	3	6	1			Becomes medium stiff				
140	6	6	6	2			Becomes dark brown				
	10	12	2	3			Becomes soft	28			
135	12	12	2	4		MC					
	15	12	14	5		GM	Gray-brown silty gravel with sand (medium dense, moist) (Linn gravels)				
130	20	12	50/6"	6			Becomes very dense				

Note: See Figure A-1 for explanation of symbols.
Coordinates Data Source: Horizontal approximated based on Aerial Imagery. Vertical approximated based on Aerial Imagery.

Log of Boring B-3



Project: Salem Cannery 6 Story Mixed-use Development
Project Location: Salem, Oregon
Project Number: 26595-001-00

Date: 3/23/23 Path: P:\26_26595001\GINT_2659500100.GPJ DBLibrary\Library\GEOENGINEERS_DF_STD_US_JUNE_2017.GLB\GEB_GEO TECH_STANDARD_%F_NO_GW

Drilled	Start 2/21/2023	End 2/21/2023	Total Depth (ft)	16	Logged By Checked By	SLG	Driller	Western States Soil Conservation	Drilling Method	Hollow-stem Auger
Surface Elevation (ft) Vertical Datum	147 NAVD88			Hammer Data	Autohammer 140 (lbs) / 30 (in) Drop			Drilling Equipment	CME 850	
Easting (X) Northing (Y)	7545401 479161			System Datum	OR State Plane NAD83 (feet)			Groundwater not observed at time of exploration		
Notes:										

Elevation (feet)	FIELD DATA					Group Classification	MATERIAL DESCRIPTION	Moisture Content (%)	Fines Content (%)	REMARKS
	Depth (feet)	Interval Recovered (in)	Blows/foot	Collected Sample	Sample Name Testing					
0						CC	Approximately 8½ inches cement concrete pavement			
1.45						CH	Dark brown clay (soft, moist) (fill)			
		8	3		1 AL			38		AL (LL = 54, PI = 31)
5		6	30		2	GM	Brown silty sandy gravel (medium dense to dense, moist) (Linn gravels)			
1.40		6	40		3		Becomes dense			
10		6	68/10"		4		Becomes gray, very dense, moist to wet			
1.35										
15		6	50/5"		5					

Note: See Figure A-1 for explanation of symbols.
Coordinates Data Source: Horizontal approximated based on Aerial Imagery. Vertical approximated based on Aerial Imagery.

Log of Boring B-4



Project: Salem Cannery 6 Story Mixed-use Development
Project Location: Salem, Oregon
Project Number: 26595-001-00

Figure A-5
Sheet 1 of 1

Date: 3/23/23 Path: P:\26_26595001\GINT\2659500100.GPJ DBLibrary\Library\GEOENGINEERS_DF_STD_US_JUNE_2017.GLB\GEB8_GEOTECH_STANDARD_%F_NO_GW

Drilled	Start 2/21/2023	End 2/21/2023	Total Depth (ft)	26	Logged By Checked By	SLG	Driller	Western States Soil Conservation	Drilling Method	Hollow-stem Auger
Surface Elevation (ft) Vertical Datum	151 NAVD88			Hammer Data	Autohammer 140 (lbs) / 30 (in) Drop			Drilling Equipment	CME 850	
Easting (X) Northing (Y)	7545517 479397			System Datum	OR State Plane NAD83 (feet)			Groundwater not observed at time of exploration		
Notes:										

Elevation (feet)	Depth (feet)	FIELD DATA				Graphic Log	Group Classification	MATERIAL DESCRIPTION	Moisture Content (%)	Fines Content (%)	REMARKS
		Interval Recovered (in)	Blows/foot	Collected Sample	Sample Name Testing						
150	0					AC GP CL	Approximately 2 inches asphalt concrete pavement Approximately 3 inches base course Brown clay (stiff, moist) (Middle Terrace deposits)				
145	5	18	10		1	AL		35		AL (LL = 37, PI - 15)	
		12	75		2	GM	Brown silty sandy gravel (very dense, moist to wet) (Linn gravels)				
140	10	12	93/10"		3						
135	15	16	26		4		Becomes medium dense				
130	20	8	71		5		Becomes very dense				
125	25	8	50/6"		6						

Note: See Figure A-1 for explanation of symbols.
Coordinates Data Source: Horizontal approximated based on Aerial Imagery. Vertical approximated based on Aerial Imagery.

Log of Boring B-5/IT-2



Project: Salem Cannery 6 Story Mixed-use Development
Project Location: Salem, Oregon
Project Number: 26595-001-00

Figure A-6
Sheet 1 of 1

Date: 3/23/23 Path: P:\26_26595001\GINT_2659500100.GPJ DBLibrary\Library\GEOENGINEERS_DF_STD_US_JUNE_2017.GLB\GEBB_GEOTECH_STANDARD_%F_NO_GW

Start Drilled	2/28/2023	End	2/28/2023	Total Depth (ft)	31.5	Logged By	JLL	Driller	Western States Soil Conservation	Drilling Method	Hollow-stem Auger
Surface Elevation (ft) Vertical Datum	152 NAVD88			Hammer Data	Autohammer 140 (lbs) / 30 (in) Drop			Drilling Equipment	CME 850		
Easting (X) Northing (Y)	7545693 479327			System Datum	OR State Plane NAD83 (feet)			See "Remarks" section for groundwater observed			
Notes:											

Elevation (feet)	FIELD DATA					Graphic Log	Group Classification	MATERIAL DESCRIPTION	Moisture Content (%)	Fines Content (%)	REMARKS
	Depth (feet)	Interval Recovered (in)	Blows/foot	Collected Sample	Sample Name Testing						
0						AC	Approximately 6 inches asphalt concrete pavement				
1.50						GP	Approximately 12 inches base course				
						ML	Gray silt with trace sand and mica (stiff, moist) (Middle Terrace Deposits)				
5		16	12		1						
14.5		16	14		2						
		9	50/5"		3	GM	Gray-brown silty gravel with sand (very dense, moist) (Linn gravels)				
10		12	77		4	GP-GM	Gray-brown gravel with silt and sand (very dense, moist)				
14.0		6	50/3"		5						
15			50/3"		6						
13.5											
						GM	Brown silty gravel with sand (very dense, moist to wet)				
20		10	52		7						
13.0						GP-GM	Brown gravel with silt and sand (very dense, moist)				
25		10	50/5"		8						
12.5											
30		12	50		9		Becomes wet				
										Groundwater observed at approximately 30½ feet during drilling	

Note: See Figure A-1 for explanation of symbols.
Coordinates Data Source: Horizontal approximated based on Aerial Imagery. Vertical approximated based on Aerial Imagery.

Log of Boring B-6/GPR-3



Project: Salem Cannery 6 Story Mixed-use Development
Project Location: Salem, Oregon
Project Number: 26595-001-00

Date: 3/23/23 Path: P:\26_26595001\GINT_2659500100.GPJ DBLibrary\Library\GEOENGINEERS_DF_STD_US_JUNE_2017.GLB\GEB_GEO TECH_STANDARD_%F_NO_GW

Drilled	Start 2/21/2023	End 2/21/2023	Total Depth (ft)	26.5	Logged By Checked By	SLG	Driller	Western States Soil Conservation	Drilling Method	Hollow-stem Auger
Surface Elevation (ft) Vertical Datum	154 NAVD88			Hammer Data	Autohammer 140 (lbs) / 30 (in) Drop			Drilling Equipment	CME 850	
Easting (X) Northing (Y)	7545605 479644			System Datum	OR State Plane NAD83 (feet)			Groundwater not observed at time of exploration		
Notes:										

Elevation (feet)	Depth (feet)	FIELD DATA				Graphic Log	Group Classification	MATERIAL DESCRIPTION	Moisture Content (%)	Fines Content (%)	REMARKS
		Interval Recovered (in)	Blows/foot	Collected Sample	Sample Name Testing						
0						ML	Dark brown silt (medium stiff, moist) (Middle Terrace deposits)				
1.50	8	6		1 MC				24			
5	18	10		2			Becomes stiff				
14.5	18	18		3 MC			Becomes very stiff	34			
10	18	22		4							
14.0	12	91/11"		5		GM	Brown silty sandy gravel (very dense, moist) (Linn gravels)				
13.5	12	7		6 MC		ML	Brown silt with occasional gravel (medium stiff, moist)	46			
13.0	12	83/10"		7		GM/GP-GM	Brown silty sandy gravel (very dense, moist)				

Note: See Figure A-1 for explanation of symbols.
Coordinates Data Source: Horizontal approximated based on Aerial Imagery. Vertical approximated based on Aerial Imagery.

Log of Boring B-7



Project: Salem Cannery 6 Story Mixed-use Development
Project Location: Salem, Oregon
Project Number: 26595-001-00

Date: 3/23/23 Path: P:\26_26595001\GINT_2659500100.GPJ DBLibrary\Library\GEOENGINEERS_DF_STD_US_JUNE_2017.GLB\GEBB_GEO TECH_STANDARD_%F_NO_GW

Drilled	Start 2/22/2002	End 2/22/2002	Total Depth (ft)	25.75	Logged By Checked By	SLG	Driller	Western States Soil Conservation	Drilling Method	Hollow-stem Auger
Surface Elevation (ft) Vertical Datum	156 NAVD88			Hammer Data	Autohammer 140 (lbs) / 30 (in) Drop			Drilling Equipment	CME 850	
Easting (X) Northing (Y)	7545766 479691			System Datum	OR State Plane NAD83 (feet)			Groundwater not observed at time of exploration		
Notes:										

Elevation (feet)	FIELD DATA					Graphic Log	Group Classification	MATERIAL DESCRIPTION	Moisture Content (%)	Fines Content (%)	REMARKS
	Depth (feet)	Interval Recovered (in)	Blows/foot	Collected Sample	Sample Name Testing						
155	0						ML	Brown with rust mottling silt (stiff, moist) (Middle Terrace deposits)			
		18	10		1				27		
	5	18	16		2			Becomes very stiff			
		18	11		3			Becomes stiff			
	10	18	12		4				28		
		18	12		MC						
	15	12	34		5		SP	Brown fine to medium sand with occasional gravel (dense, moist)			
		12	34								
	20	6	50/3"		6		GM	Brown silty gravel with sand (very dense, moist) (Linn gravels)			
		6	50/3"								
	25	6	50/3"		7						
		6	50/3"								

Note: See Figure A-1 for explanation of symbols.
Coordinates Data Source: Horizontal approximated based on Aerial Imagery. Vertical approximated based on Aerial Imagery.

Log of Boring B-8



Project: Salem Cannery 6 Story Mixed-use Development
Project Location: Salem, Oregon
Project Number: 26595-001-00

Date: 3/23/23 Path: P:\26_26595001\GINT_2659500100.GPJ DBLibrary\Library\GEOENGINEERS_DF_STD_US_JUNE_2017.GLB\GEBB_GEOTECH_STANDARD_%F_NO_GW

Drilled	Start 2/20/2023	End 2/20/2023	Total Depth (ft)	21.5	Logged By Checked By	SLG	Driller	Western States Soil Conservation	Drilling Method	Hollow-stem Auger
Surface Elevation (ft) Vertical Datum	153 NAVD88			Hammer Data	Autohammer 140 (lbs) / 30 (in) Drop			Drilling Equipment	CME 850	
Easting (X) Northing (Y)	7545697 479408			System Datum	OR State Plane NAD83 (feet)			Groundwater not observed at time of exploration		
Notes:										

Elevation (feet)	Depth (feet)	FIELD DATA				Graphic Log	Group Classification	MATERIAL DESCRIPTION	Moisture Content (%)	Fines Content (%)	REMARKS
		Interval Recovered (in)	Blows/foot	Collected Sample	Sample Name Testing						
0						AC	Approximately 2 inches asphalt concrete pavement				
						GP	Approximately 3 inches base course				
1.50		14	9		1	ML	Dark brown silt (stiff, moist) (Middle Terrace deposits)	35			
	5	18	8		2		Becomes medium stiff				
1.45		18	46		3	GM	Brown silty gravel with sand (dense, moist) (Linn gravels)				
		18	63		4						
1.40		18	63		5						
	15	18	16		6	SM/ML	Dark brown silty fine sand to sandy silt (medium dense to very stiff, moist)				
1.35		18	16		7	GM	Brown silty gravel with sand (medium dense, moist)				
	20	12	43		8		Becomes dense				

Note: See Figure A-1 for explanation of symbols.
Coordinates Data Source: Horizontal approximated based on Aerial Imagery. Vertical approximated based on Aerial Imagery.

Log of Boring B-9



Project: Salem Cannery 6 Story Mixed-use Development
Project Location: Salem, Oregon
Project Number: 26595-001-00

Figure A-10
Sheet 1 of 1

Date: 3/23/23 Path: P:\26_26595001\GINT_2659500100.GPJ DBLibrary\Library\GEOENGINEERS_DF_STD_US_JUNE_2017.GLB\GEB8_GEO TECH_STANDARD_%F_NO_GW

Start Drilled	2/22/2002	End	2/22/2002	Total Depth (ft)	26.5	Logged By	SLG	Checked By		Driller	Western States Soil Conservation	Drilling Method	Hollow-stem Auger
Surface Elevation (ft) Vertical Datum	159 NAVD88			Hammer Data	Autohammer 140 (lbs) / 30 (in) Drop			Drilling Equipment		CME 850			
Easting (X) Northing (Y)	7545652 479807			System Datum	OR State Plane NAD83 (feet)			Groundwater not observed at time of exploration					
Notes:													

Elevation (feet)	Depth (feet)	FIELD DATA				Graphic Log	Group Classification	MATERIAL DESCRIPTION	Moisture Content (%)	Fines Content (%)	REMARKS
		Interval Recovered (in)	Blows/foot	Collected Sample	Sample Name Testing						
0						ML	Brown with rust colored mottling silt (medium stiff, moist) (Middle Terrace deposits)				
1.55	1.55	18	7		1 MC			29			
5	5	18	9		2		Becomes stiff				
150	150	18	9		3						
10	10	18	9		4 MC			33			
145	145	18	14		5						
140	140	12	50/6"		6 7	SM	Brown silty fine to medium sand (dense, moist)				
135	135	12	69		8	GM	Brown silty gravel with sand (very dense, moist) (Linn gravels)				

Note: See Figure A-1 for explanation of symbols.
Coordinates Data Source: Horizontal approximated based on Aerial Imagery. Vertical approximated based on Aerial Imagery.

Log of Boring B-10/IT-3



Project: Salem Cannery 6 Story Mixed-use Development
Project Location: Salem, Oregon
Project Number: 26595-001-00

Date: 3/23/23 Path: P:\26_26595001\GINT_2659500100.GPJ DBLibrary\Library\GEOENGINEERS_DF_STD_US_JUNE_2017.GLB\GEBB_GEO TECH_STANDARD_%F_NO_GW

Drilled	Start 2/22/2002	End 2/22/2002	Total Depth (ft)	26	Logged By Checked By	SLG	Driller	Western States Soil Conservation	Drilling Method	Hollow-stem Auger
Surface Elevation (ft) Vertical Datum	159 NAVD88		Hammer Data	Autohammer 140 (lbs) / 30 (in) Drop		Drilling Equipment		CME 850		
Easting (X) Northing (Y)	7545700 479947		System Datum	OR State Plane NAD83 (feet)		Groundwater not observed at time of exploration				
Notes:										

Elevation (feet)	Depth (feet)	FIELD DATA				Graphic Log	Group Classification	MATERIAL DESCRIPTION	Moisture Content (%)	Fines Content (%)	REMARKS
		Interval Recovered (in)	Blows/foot	Collected Sample	Sample Name Testing						
0						ML	Brown with rust colored mottling silt (stiff, moist) (Middle Terrace deposits)				
1.55	18	10		1 MC				28			
5	18	9		2 MC				29			
150	18	11		3							
10	18	11		4 MC				33			
145	18	30		5			Becomes hard				
140						SM	Brown silty fine to medium sand (dense, moist) (Linn gravels)				
						GM	Brown silty gravel with sand (very dense, moist)				
20	12	60		6							
135	6	50/4"		7							
25											

Note: See Figure A-1 for explanation of symbols.
Coordinates Data Source: Horizontal approximated based on Aerial Imagery. Vertical approximated based on Aerial Imagery.

Log of Boring B-11



Project: Salem Cannery 6 Story Mixed-use Development
Project Location: Salem, Oregon
Project Number: 26595-001-00

Figure A-12
Sheet 1 of 1

Date: 3/23/23 Path: P:\26_26595001\GINT_2659500100.GPJ DBLibrary\Library\GEOENGINEERS_DF_STD_US_JUNE_2017.GLB\GERB_GEO TECH_STANDARD_%F_NO_GW

Drilled	Start 2/22/2002	End 2/22/2023	Total Depth (ft)	26.5	Logged By Checked By	SLG	Driller	Western States Soil Conservation	Drilling Method	Hollow-stem Auger
Surface Elevation (ft) Vertical Datum	156 NAVD88			Hammer Data	Autohammer 140 (lbs) / 30 (in) Drop			Drilling Equipment	CME 850	
Easting (X) Northing (Y)	7545863 479902			System Datum	OR State Plane NAD83 (feet)			Groundwater not observed at time of exploration		
Notes:										

Elevation (feet)	Depth (feet)	FIELD DATA				Graphic Log	Group Classification	MATERIAL DESCRIPTION	Moisture Content (%)	Fines Content (%)	REMARKS
		Interval Recovered (in)	Blows/foot	Collected Sample	Sample Name Testing						
155	0					ML	Brown with rust colored mottling silt (soft, moist) (Middle Terrace deposits)				
	3	12	3		1			29			
	5	18	10		2		Becomes stiff				
150	6	18	6		3	MC	Becomes medium stiff	33			
	10	18	15		4		Becomes stiff				
145	15	18	18		5		With occasional silty fine sand interbedded approximately 2 to 3 inches thick, becomes very stiff				
140	20	12	41		6 7	GM	Brown silty gravel with sand (dense, moist) (Linn gravels)				
135	25	12	85		7		Becomes very dense				
130											

Note: See Figure A-1 for explanation of symbols.
Coordinates Data Source: Horizontal approximated based on Aerial Imagery. Vertical approximated based on Aerial Imagery.

Log of Boring B-12



Project: Salem Cannery 6 Story Mixed-use Development
Project Location: Salem, Oregon
Project Number: 26595-001-00

Figure A-13
Sheet 1 of 1

Date: 3/23/23 Path: P:\26_26595001\GINT_2659500100.GPJ DBLibrary\Library\GEOENGINEERS_DF_STD_US_JUNE_2017.GLB\GEBB_GEOTECH_STANDARD_%F_NO_GW

Drilled	Start 2/21/2023	End 2/21/2023	Total Depth (ft)	41	Logged By Checked By	SLG	Driller	Western States Soil Conservation	Drilling Method	Hollow-stem Auger
Surface Elevation (ft) Vertical Datum	147 NAVD88		Hammer Data	Autohammer 140 (lbs) / 30 (in) Drop		Drilling Equipment		CME 850		
Easting (X) Northing (Y)	7545245 478657		System Datum	OR State Plane NAD83 (feet)		See "Remarks" section for groundwater observed				
Notes:										

Elevation (feet)	Depth (feet)	FIELD DATA				Graphic Log	Group Classification	MATERIAL DESCRIPTION	Moisture Content (%)	Fines Content (%)	REMARKS
		Interval Recovered (in)	Blows/foot	Collected Sample	Sample Name Testing						
0						CC	Approximately 7 inches cement concrete pavement				
1.45						GM	Brown silty gravel (very dense, moist) (fill)				
	5	12	52		1						
1.40		8	32		2		Becomes dense				
	10	3	10		3	SM	Brown silty sand with gravel (loose to medium dense, moist)				
1.35						GM	Brown silty gravel with sand (medium dense, moist)				
	15	6	11		4						
1.30						ML	Brown silt with occasional gravel (soft, moist)				
	20	18	6		5						
1.25					6		Becomes gray to black with occasional organic matter				
	25	12	75		7	GM	Brown silty gravel with sand (very dense, moist) (Linn gravels)				
1.20											
	30	6	51		8		Becomes wet			Groundwater observed at approximately 30 feet during drilling	
1.15						SM	Gray silty fine to medium sand with trace gravel (dense, wet)				
35											

Note: See Figure A-1 for explanation of symbols.
Coordinates Data Source: Horizontal approximated based on Aerial Imagery. Vertical approximated based on Aerial Imagery.

Log of Boring B-13/IT-1



Project: Salem Cannery 6 Story Mixed-use Development
Project Location: Salem, Oregon
Project Number: 26595-001-00

Date: 3/23/23 Path: P:\26_26595001\GINT_2659500100.GPJ DBLibrary\Library\GEOENGINEERS_DF_STD_US_JUNE_2017.GLB\GEBB_GEOTECH_STANDARD_%F_NO_GW

Date: 3/23/23 Path: P:\26_26595001\GINT_2659500100.gpj DBLibrary\Library\GEOENGINEERS_DF_STD_US_JUNE_2017.GLB\GERB_GEOTECH_STANDARD_%F_NO_GW

Elevation (feet)	FIELD DATA					Group Classification	MATERIAL DESCRIPTION	Moisture Content (%)	Fines Content (%)	REMARKS
	Depth (feet)	Interval Recovered (in)	Blows/foot	Collected Sample	Sample Name Testing					
38	18	38		9		GM	Brown silty gravel with sand (dense, wet)			
40	4	50/4"		11						

Log of Boring B-13/IT-1 (continued)



Project: Salem Cannery 6 Story Mixed-use Development
 Project Location: Salem, Oregon
 Project Number: 26595-001-00

GeoEngineers / CPT-1 / 1105 Front St NE Salem

OPERATOR: OGE DMM
 CONE ID: DDG1296
 TEST DATE: 2/25/2023 10:44:59 AM
 TOTAL DEPTH: 14.108 ft

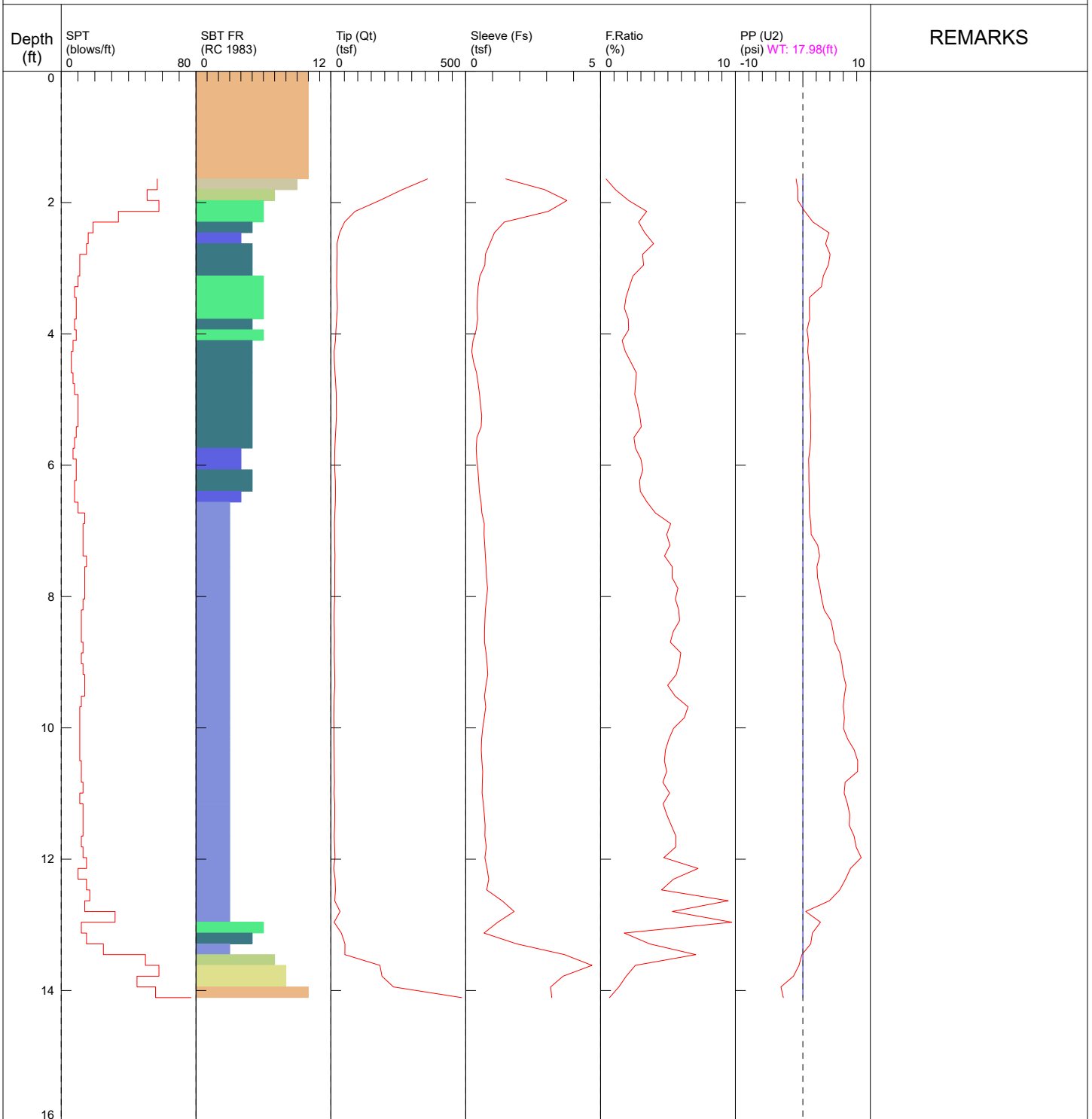

- | | | | |
|---|--|--|--|
| <ul style="list-style-type: none"> ■ 1 sensitive fine grained ■ 2 organic material ■ 3 clay | <ul style="list-style-type: none"> ■ 4 silty clay to clay ■ 5 clayey silt to silty clay ■ 6 sandy silt to clayey silt | <ul style="list-style-type: none"> ■ 7 silty sand to sandy silt ■ 8 sand to silty sand ■ 9 sand | <ul style="list-style-type: none"> ■ 10 gravelly sand to sand ■ 11 very stiff fine grained (*) ■ 12 sand to clayey sand (*) |
|---|--|--|--|

*SBT/SPT CORRELATION: UBC-1983

COMMENT: GeoEngineers / CPT-1 / 1105 Front St NE Salem

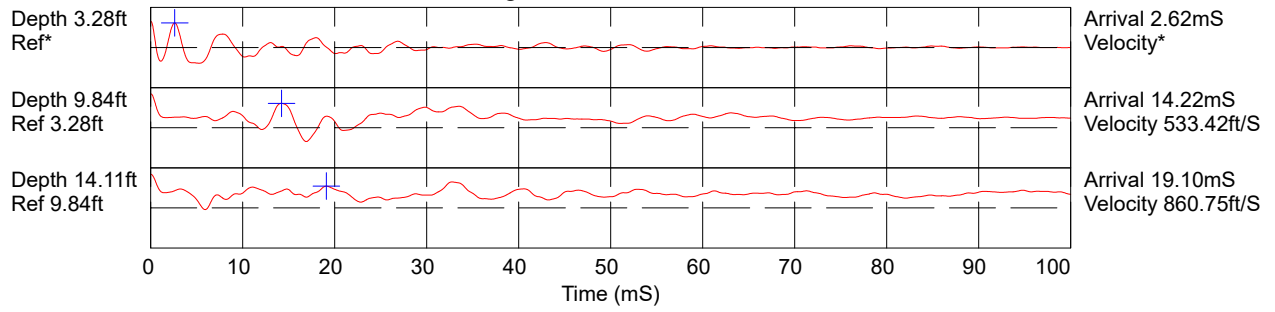

Hammer to Rod String Distance (ft): 2.04
* = Not Determined

GeoEngineers / CPT-1 / 1105 Front St NE Salem

OPERATOR: OGE DMM
 CONE ID: DDG1296
 TEST DATE: 2/25/2023 10:44:59 AM
 TOTAL DEPTH: 14.108 ft

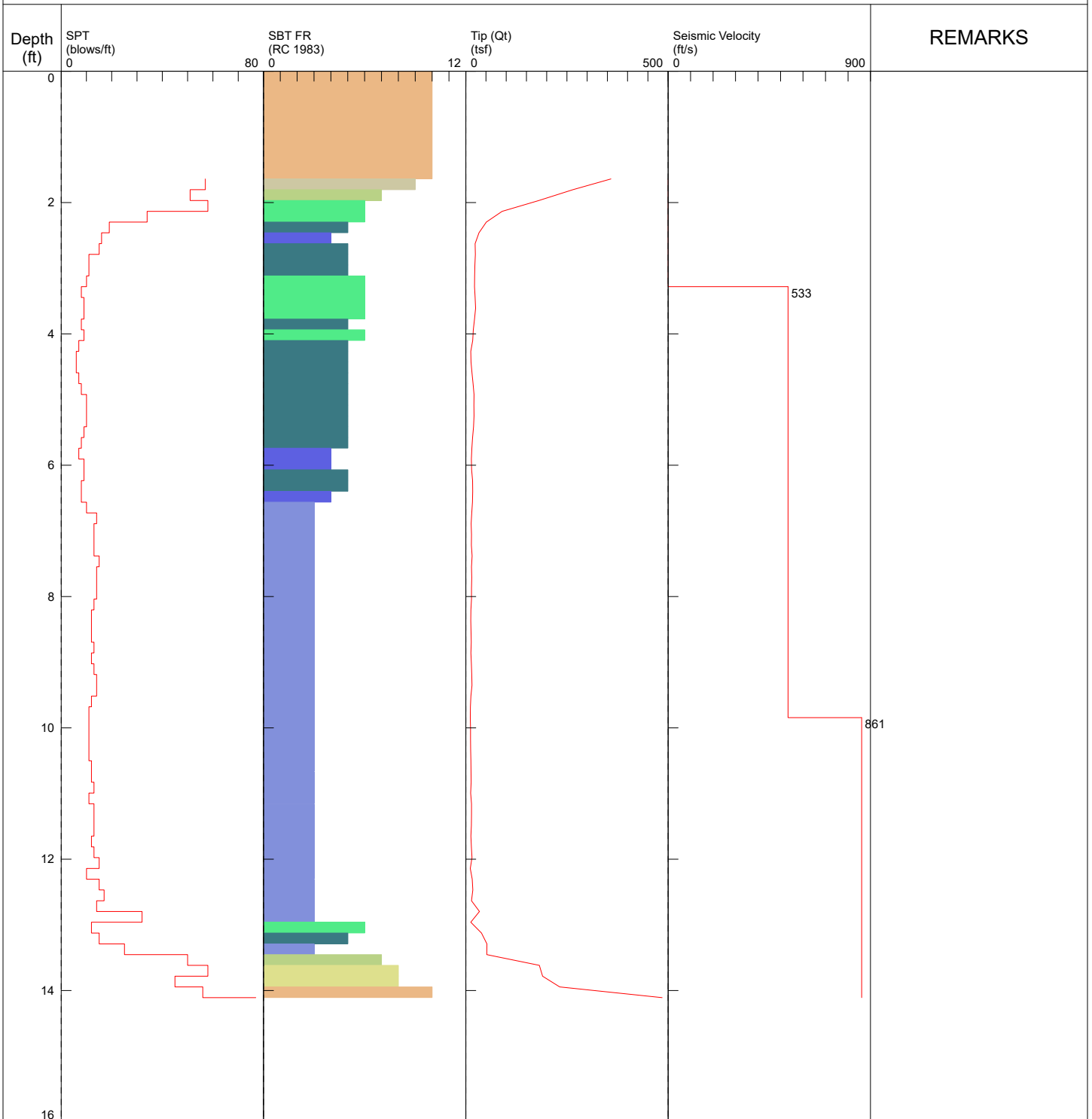

- | | | | |
|---|---|--|--|
| <ul style="list-style-type: none"> ■ 1 sensitive fine grained ■ 2 organic material ■ 3 clay | <ul style="list-style-type: none"> ■ 4 silty clay to clay ■ 5 clayey silt to silty clay ■ 6 sandy silt to clayey silt | <ul style="list-style-type: none"> ■ 7 silty sand to sandy silt ■ 8 sand to silty sand ■ 9 sand | <ul style="list-style-type: none"> ■ 10 gravelly sand to sand ■ 11 very stiff fine grained (*) ■ 12 sand to clayey sand (*) |
|---|---|--|--|

*SBT/SPT CORRELATION: UBC-1983

COMMENT: GeoEngineers / CPT-1 / 1105 Front St NE Salem

CONE ID: DDG1296
TEST DATE: 2/25/2023 10:44:59 AM

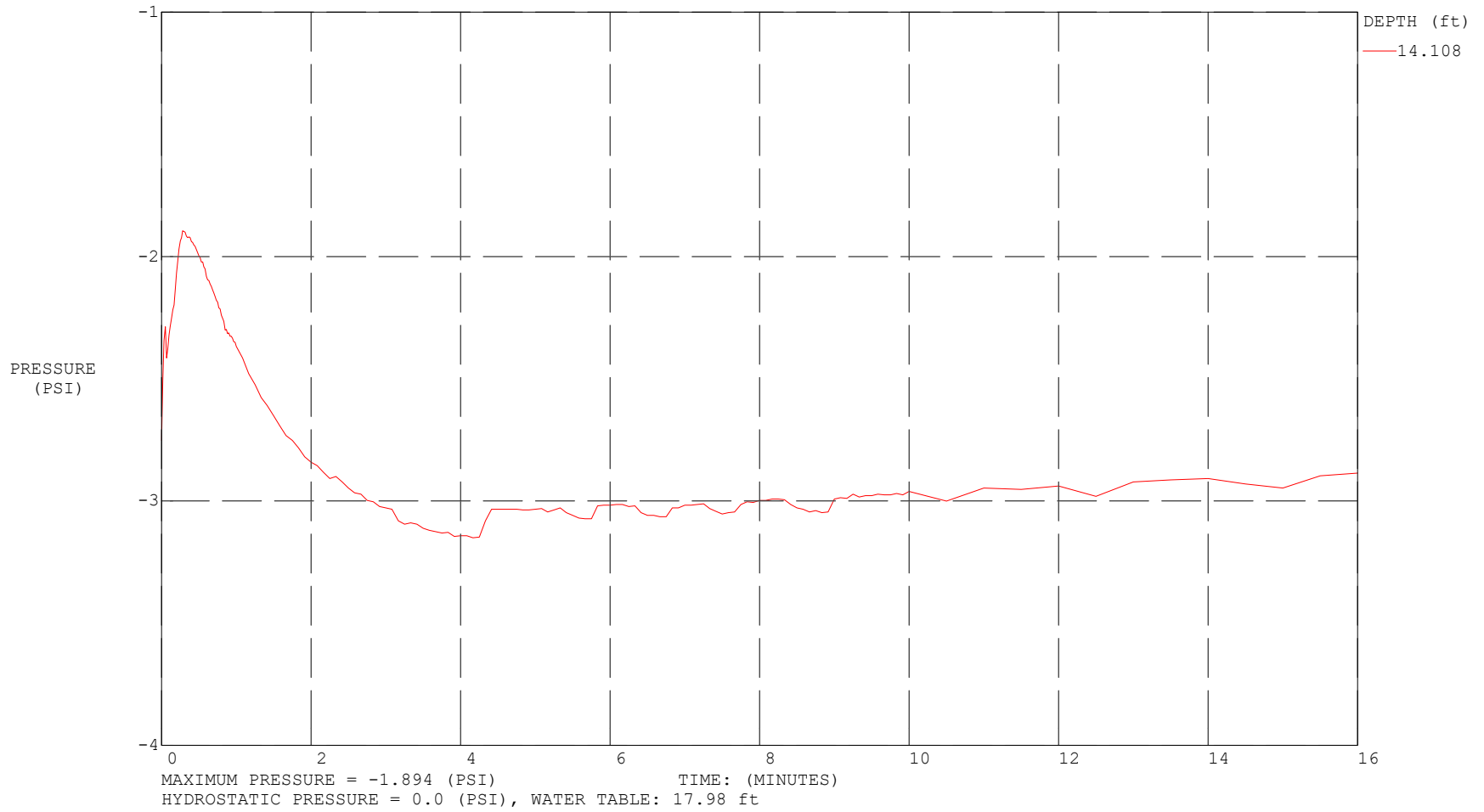

GeoEngineers / CPT-2 / 1105 Front St NE Salem

OPERATOR: OGE DMM
 CONE ID: DDG1296
 TEST DATE: 2/25/2023 9:52:27 AM
 TOTAL DEPTH: 6.726 ft

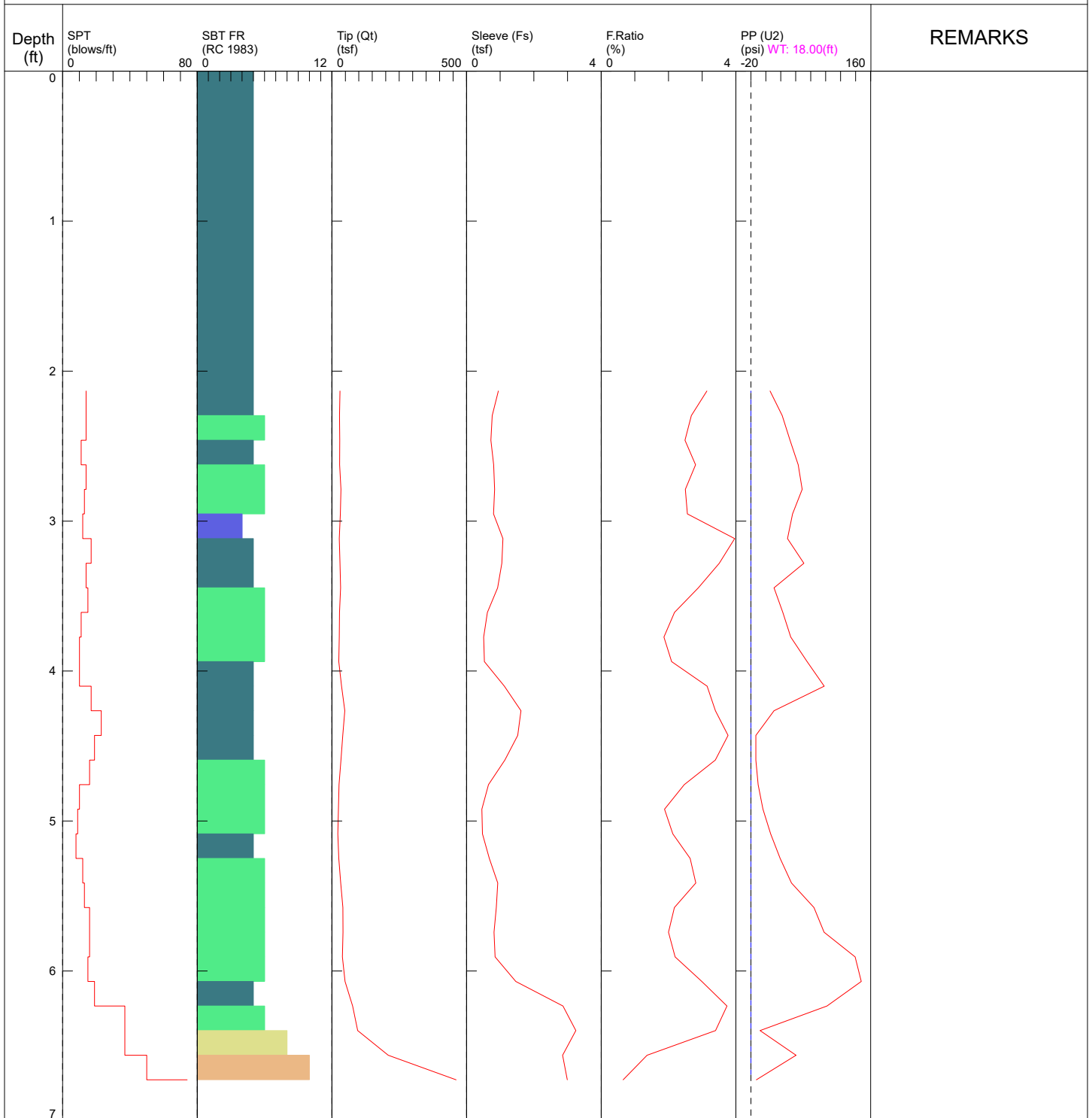

- | | | | |
|---|---|--|--|
| <ul style="list-style-type: none"> ■ 1 sensitive fine grained ■ 2 organic material ■ 3 clay | <ul style="list-style-type: none"> ■ 4 silty clay to clay ■ 5 clayey silt to silty clay ■ 6 sandy silt to clayey silt | <ul style="list-style-type: none"> ■ 7 silty sand to sandy silt ■ 8 sand to silty sand ■ 9 sand | <ul style="list-style-type: none"> ■ 10 gravelly sand to sand ■ 11 very stiff fine grained (*) ■ 12 sand to clayey sand (*) |
|---|---|--|--|

*SBT/SPT CORRELATION: UBC-1983

COMMENT: GeoEngineers / CPT-2 / 1105 Front St NE Salem

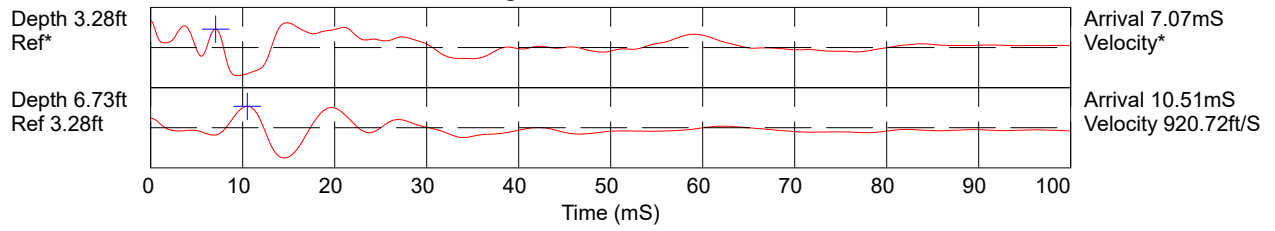

Hammer to Rod String Distance (ft): 2.04
* = Not Determined

GeoEngineers / CPT-2 / 1105 Front St NE Salem

OPERATOR: OGE DMM
 CONE ID: DDG1296
 TEST DATE: 2/25/2023 9:52:27 AM
 TOTAL DEPTH: 6.726 ft

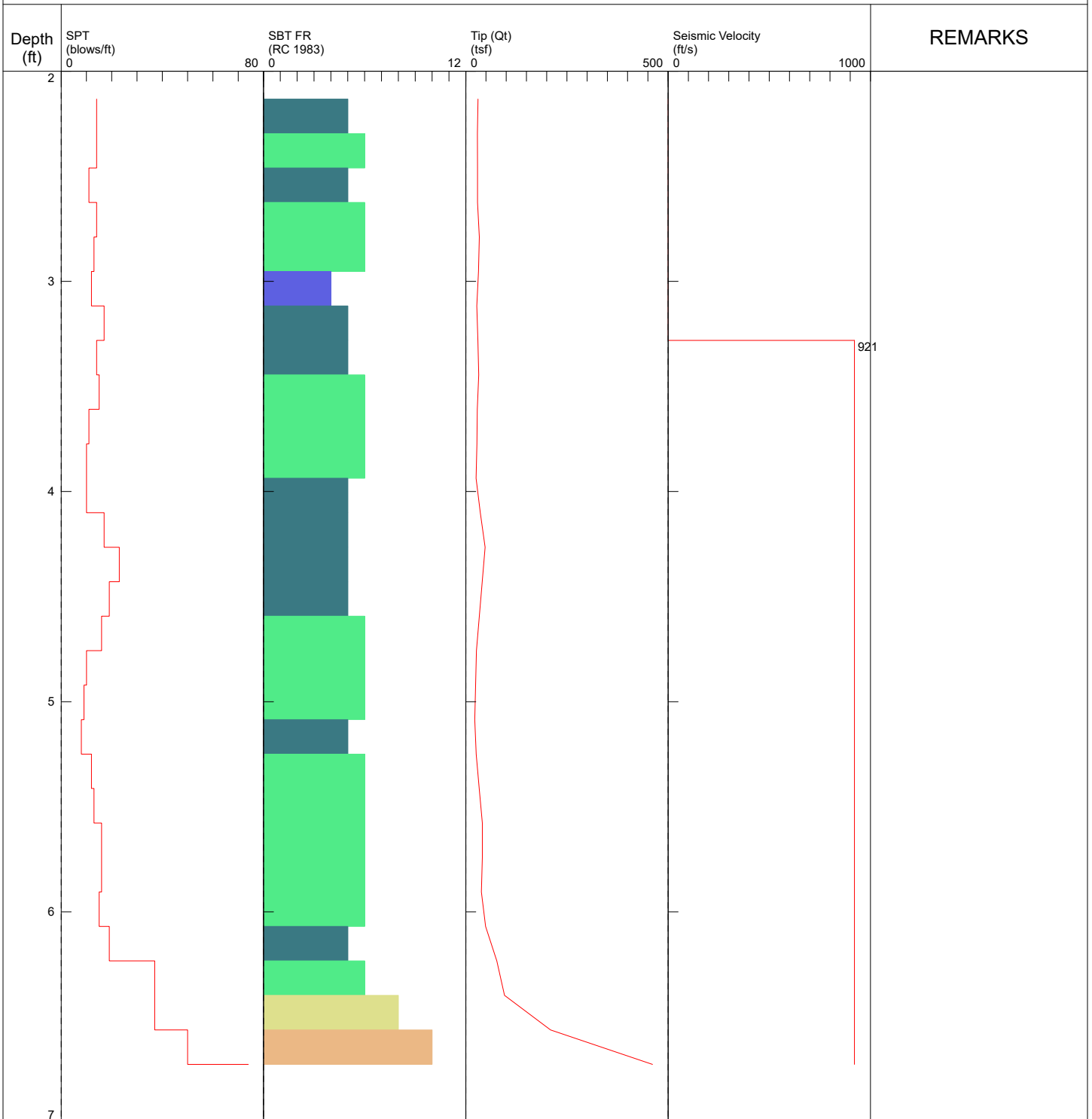

- | | | | |
|---|---|--|--|
| <ul style="list-style-type: none"> ■ 1 sensitive fine grained ■ 2 organic material ■ 3 clay | <ul style="list-style-type: none"> ■ 4 silty clay to clay ■ 5 clayey silt to silty clay ■ 6 sandy silt to clayey silt | <ul style="list-style-type: none"> ■ 7 silty sand to sandy silt ■ 8 sand to silty sand ■ 9 sand | <ul style="list-style-type: none"> ■ 10 gravelly sand to sand ■ 11 very stiff fine grained (*) ■ 12 sand to clayey sand (*) |
|---|---|--|--|

*SBT/SPT CORRELATION: UBC-1983

GeoEngineers / CPT-3 / 1105 Front St NE Salem

OPERATOR: OGE DMM
 CONE ID: DDG1296
 TEST DATE: 2/25/2023 12:10:55 PM
 TOTAL DEPTH: 10.335 ft

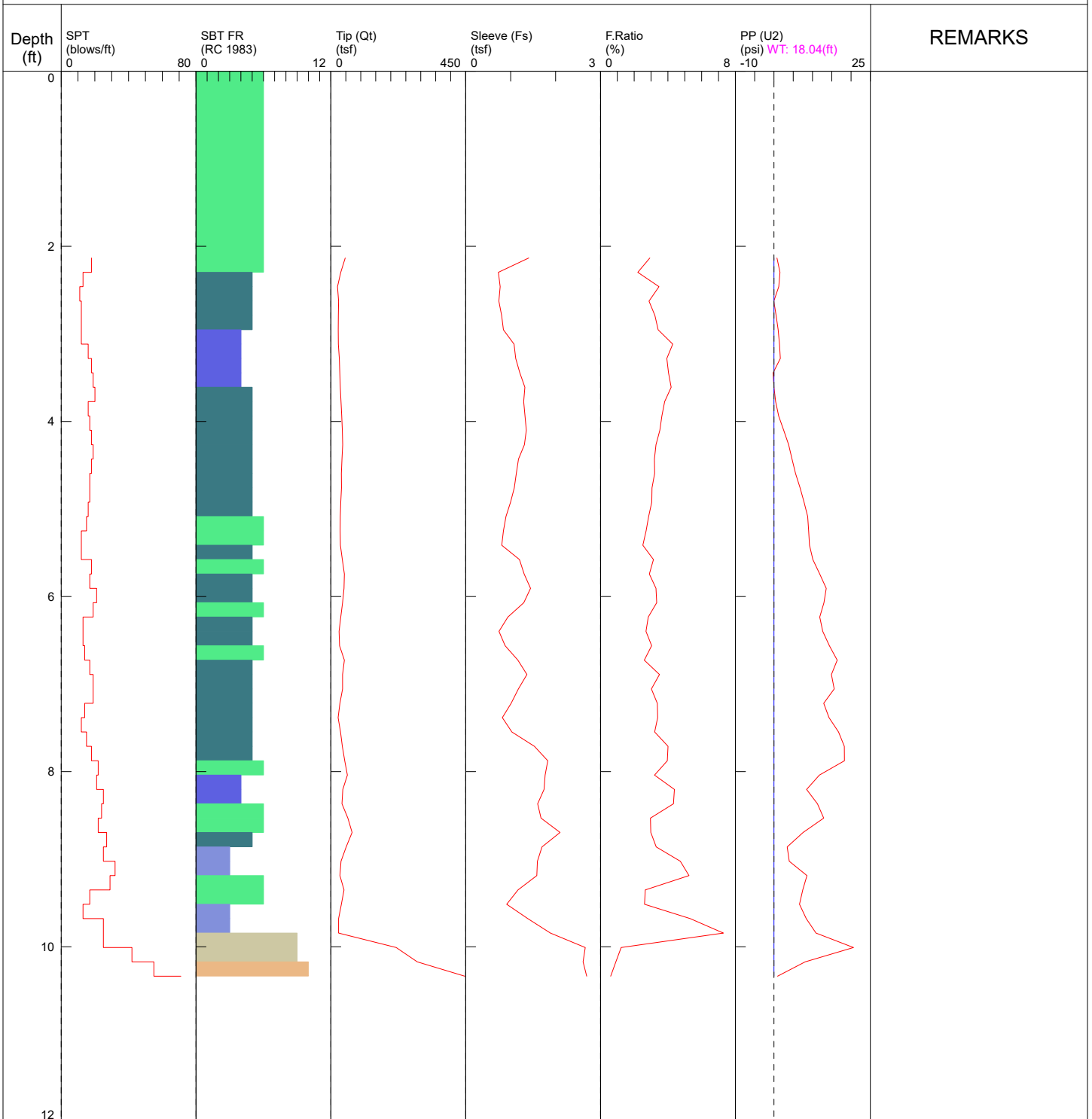

- | | | | |
|---|---|--|--|
| <ul style="list-style-type: none"> ■ 1 sensitive fine grained ■ 2 organic material ■ 3 clay | <ul style="list-style-type: none"> ■ 4 silty clay to clay ■ 5 clayey silt to silty clay ■ 6 sandy silt to clayey silt | <ul style="list-style-type: none"> ■ 7 silty sand to sandy silt ■ 8 sand to silty sand ■ 9 sand | <ul style="list-style-type: none"> ■ 10 gravelly sand to sand ■ 11 very stiff fine grained (*) ■ 12 sand to clayey sand (*) |
|---|---|--|--|

*SBT/SPT CORRELATION: UBC-1983

COMMENT: GeoEngineers / CPT-3 / 1105 Front St NE Salem

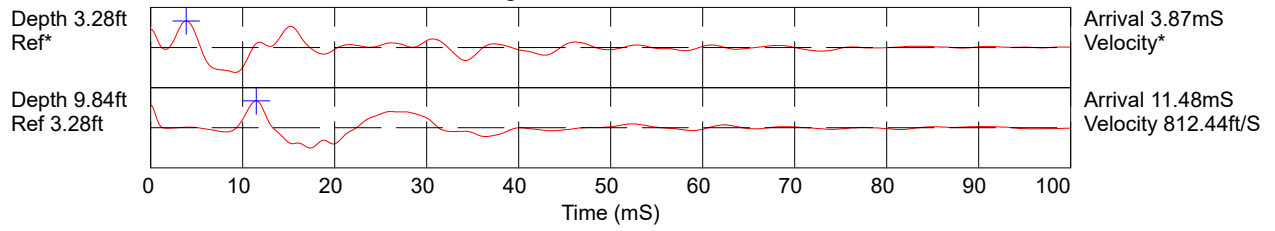

Hammer to Rod String Distance (ft): 2.04
* = Not Determined

GeoEngineers / CPT-3 / 1105 Front St NE Salem

OPERATOR: OGE DMM
 CONE ID: DDG1296
 TEST DATE: 2/25/2023 12:10:55 PM
 TOTAL DEPTH: 10.335 ft

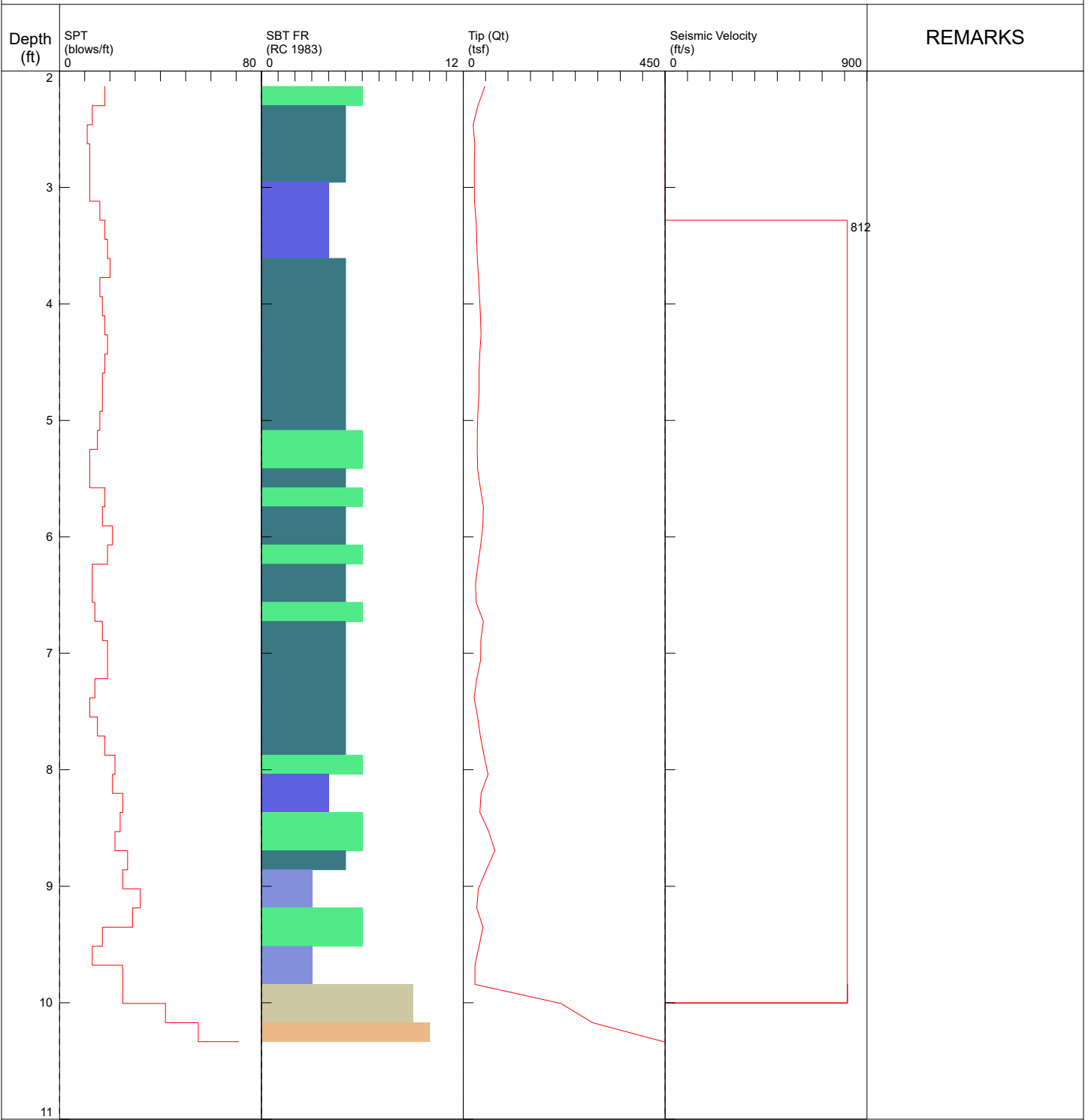

- | | | | |
|---|--|--|--|
| <ul style="list-style-type: none"> ■ 1 sensitive fine grained ■ 2 organic material ■ 3 clay | <ul style="list-style-type: none"> ■ 4 silty clay to clay ■ 5 clayey silt to silty clay ■ 6 sandy silt to clayey silt | <ul style="list-style-type: none"> ■ 7 silty sand to sandy silt ■ 8 sand to silty sand ■ 9 sand | <ul style="list-style-type: none"> ■ 10 gravelly sand to sand ■ 11 very stiff fine grained (*) ■ 12 sand to clayey sand (*) |
|---|--|--|--|

*SBT/SPT CORRELATION: UBC-1983

GeoEngineers / CPT-4 / 1105 Front St NE Salem

OPERATOR: OGE DMM
 CONE ID: DDG1296
 TEST DATE: 2/25/2023 12:41:11 PM
 TOTAL DEPTH: 18.373 ft

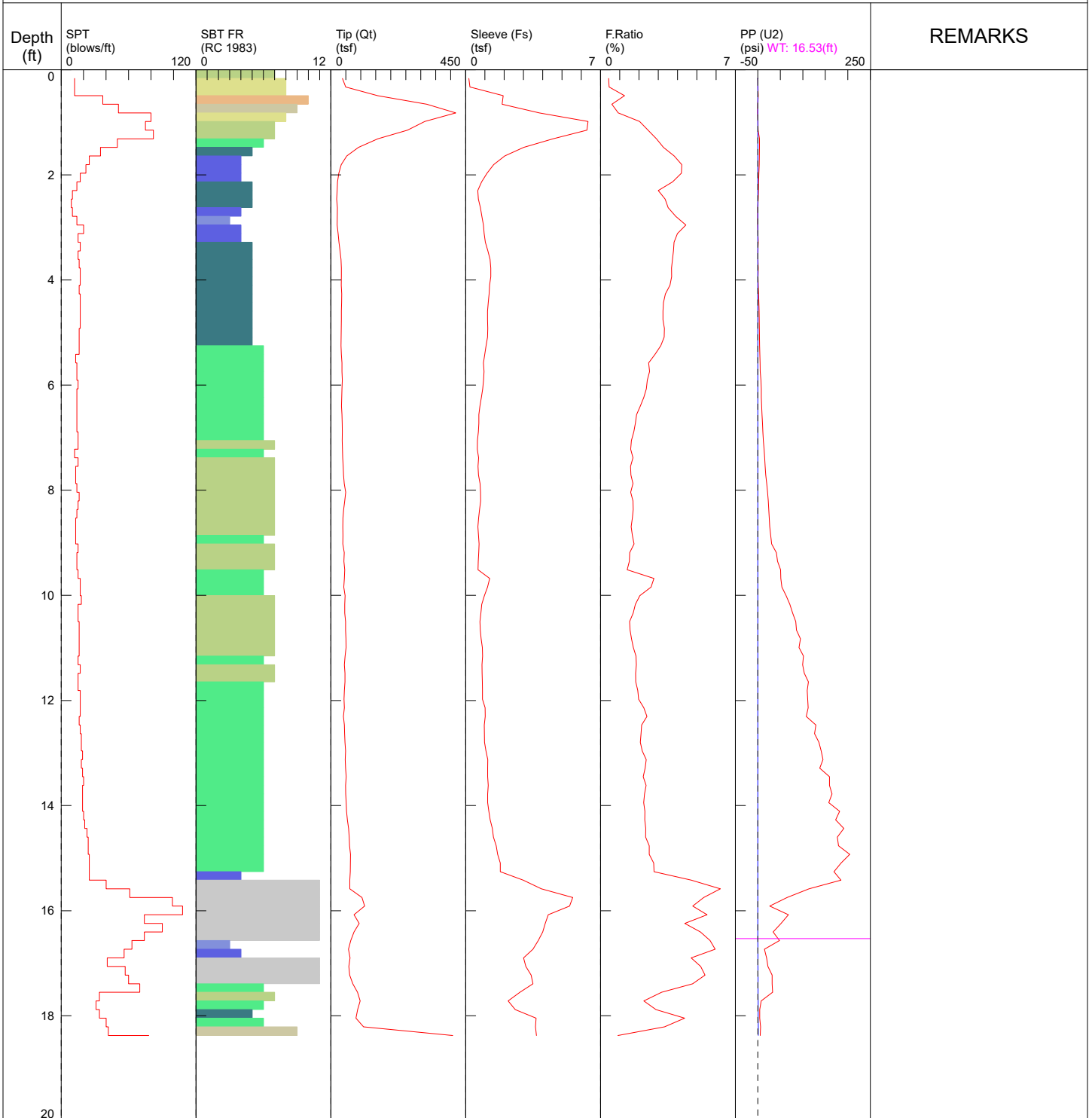

- | | | | |
|---|--|--|--|
| <ul style="list-style-type: none"> ■ 1 sensitive fine grained ■ 2 organic material ■ 3 clay | <ul style="list-style-type: none"> ■ 4 silty clay to clay ■ 5 clayey silt to silty clay ■ 6 sandy silt to clayey silt | <ul style="list-style-type: none"> ■ 7 silty sand to sandy silt ■ 8 sand to silty sand ■ 9 sand | <ul style="list-style-type: none"> ■ 10 gravelly sand to sand ■ 11 very stiff fine grained (*) ■ 12 sand to clayey sand (*) |
|---|--|--|--|

*SBT/SPT CORRELATION: UBC-1983

COMMENT: GeoEngineers / CPT-4 / 1105 Front St NE Salem

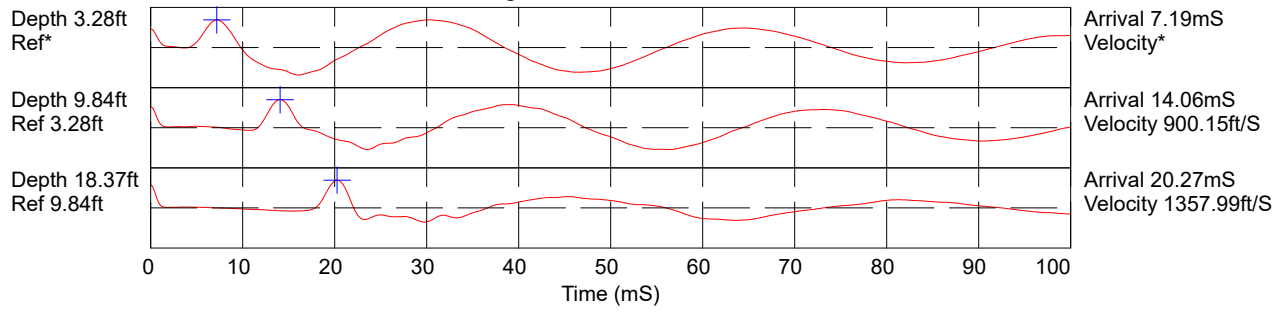

Hammer to Rod String Distance (ft): 2.04
* = Not Determined

GeoEngineers / CPT-4 / 1105 Front St NE Salem

OPERATOR: OGE DMM
 CONE ID: DDG1296
 TEST DATE: 2/25/2023 12:41:11 PM
 TOTAL DEPTH: 18.373 ft

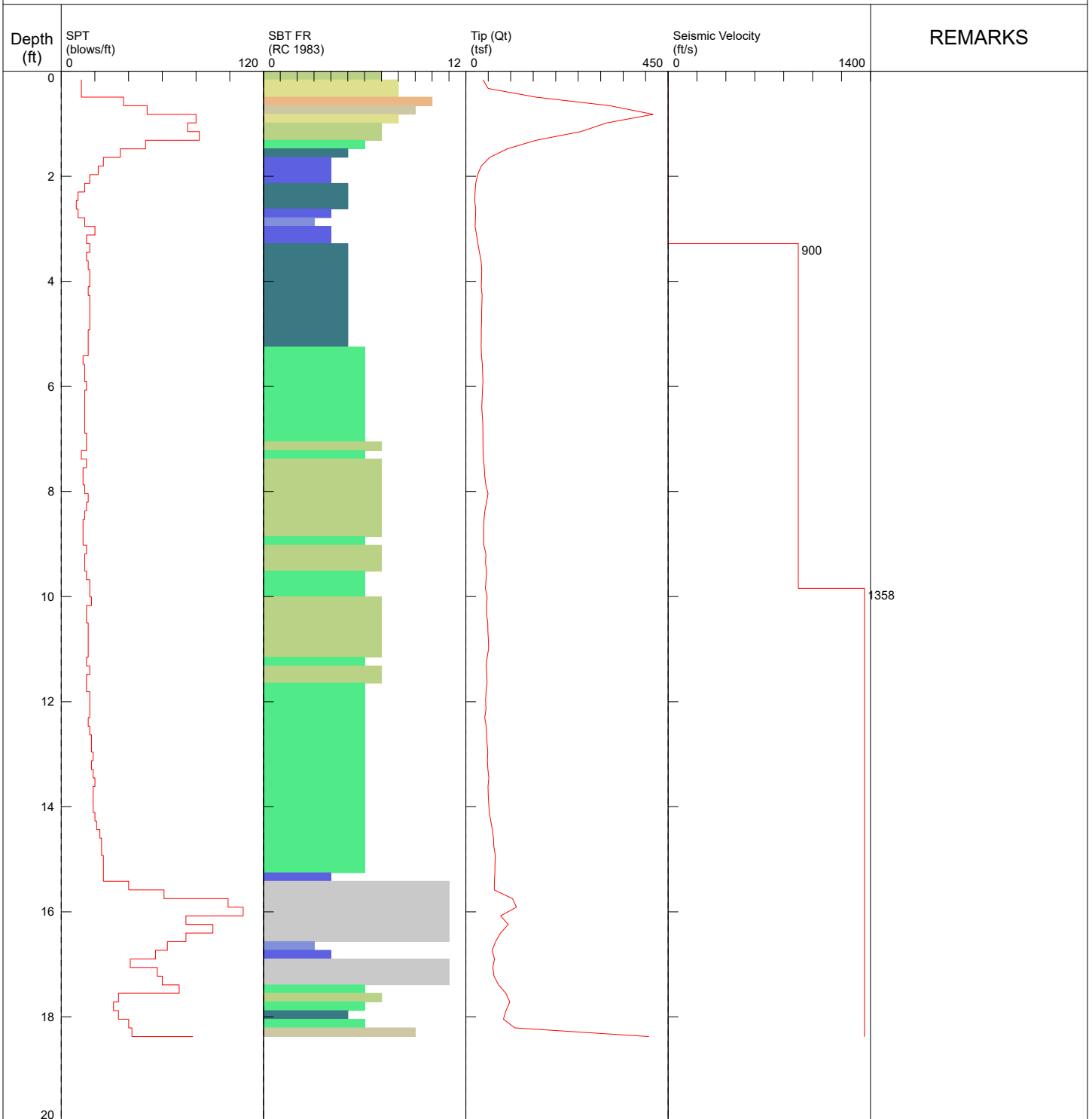

- | | | | |
|---|---|--|--|
| <ul style="list-style-type: none"> ■ 1 sensitive fine grained ■ 2 organic material ■ 3 clay | <ul style="list-style-type: none"> ■ 4 silty clay to clay ■ 5 clayey silt to silty clay ■ 6 sandy silt to clayey silt | <ul style="list-style-type: none"> ■ 7 silty sand to sandy silt ■ 8 sand to silty sand ■ 9 sand | <ul style="list-style-type: none"> ■ 10 gravelly sand to sand ■ 11 very stiff fine grained (*) ■ 12 sand to clayey sand (*) |
|---|---|--|--|

*SBT/SPT CORRELATION: UBC-1983

COMMENT: GeoEngineers / CPT-4 / 1105 Front St NE Salem

CONE ID: DDG1296
TEST DATE: 2/25/2023 12:41:11 PM

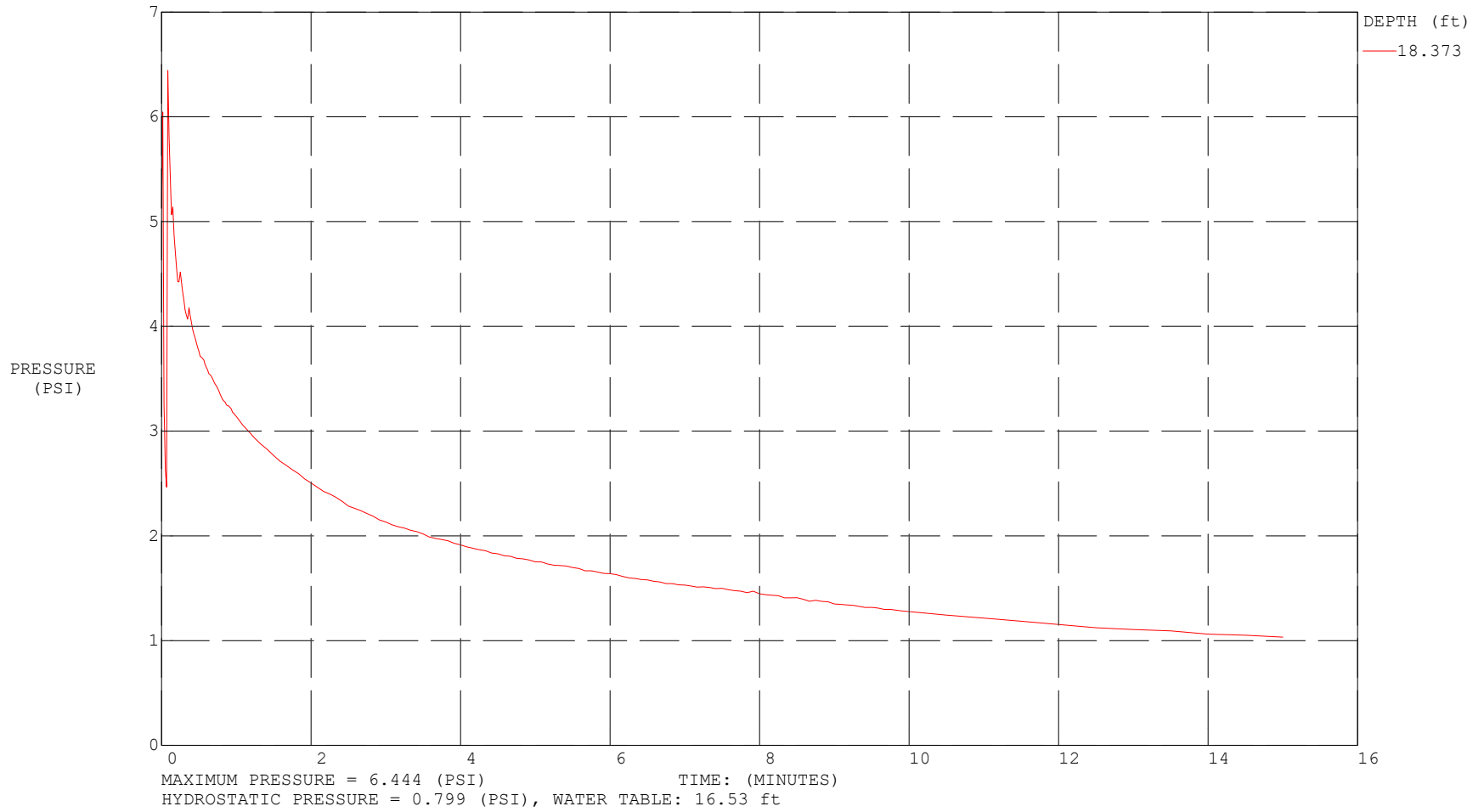

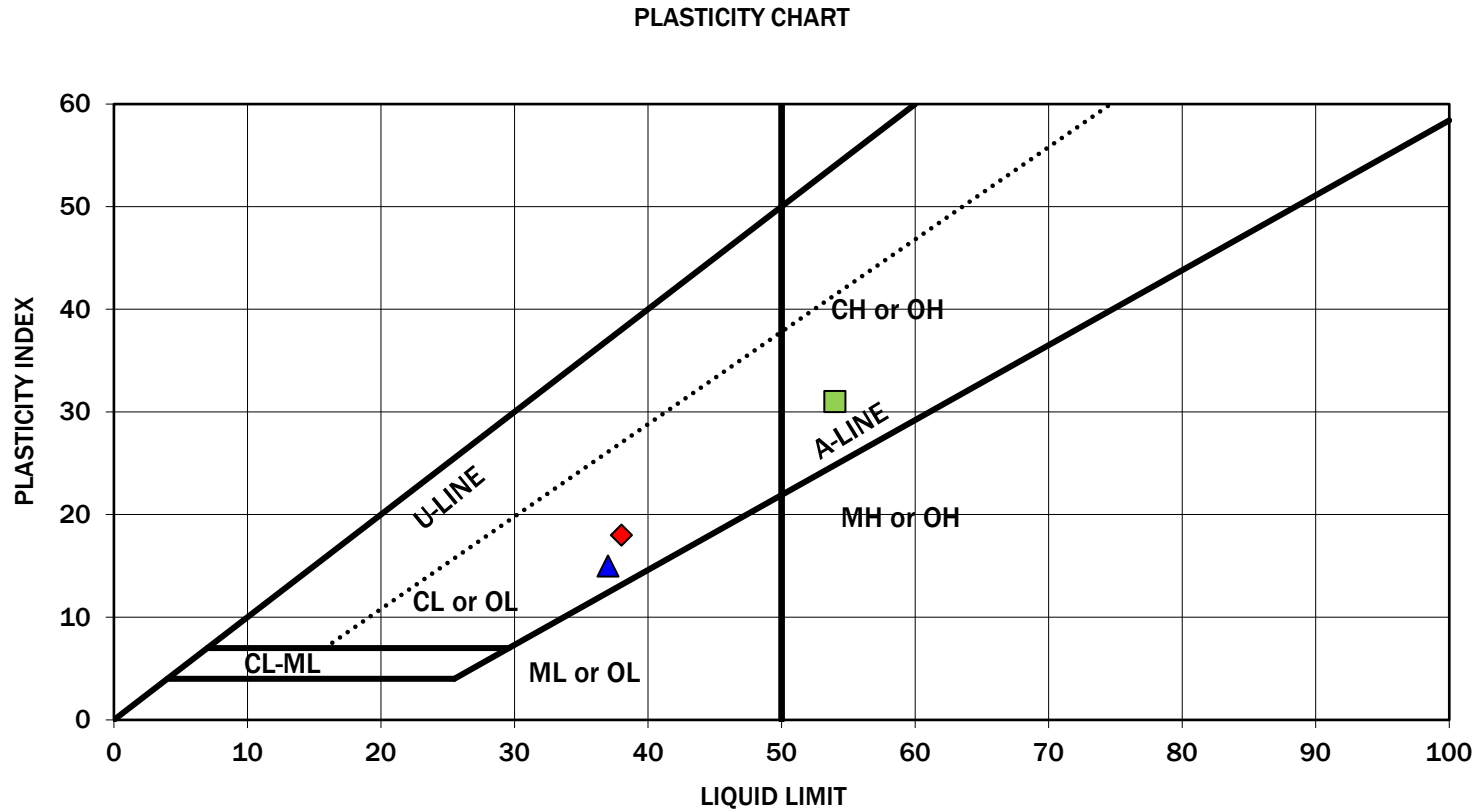

Symbol	Boring Number	Depth (feet)	Moisture Content (%)	Liquid Limit (%)	Plasticity Index (%)	Soil Description
◆	B-3	2.5	31	38	18	Lean clay (CL)
■	B-4	2.5	38	54	31	Fat clay (CH)
▲	B-5/IT-2	5	35	37	15	Lean clay (CL)

Atterberg Limits Test Results

Salem Cannery 6 Story Mixed Use Development
Salem, Oregon



Figure A-19

Note: This report may not be reproduced, except in full, without written approval of GeoEngineers, Inc. Test results are applicable only to the specific sample on which they were performed and should not be interpreted as representative of any other samples obtained at other times, depths or locations, or generated by separate operations or processes. The liquid limit and plasticity index were obtained in general accordance with ASTM D 4318. GeoEngineers 17425 NE Union Hill Road Ste 250, Redmond, WA 98052

APPENDIX B
Geologic Hazard Assessment

APPENDIX B GEOLOGIC HAZARD ASSESSMENT

GeoEngineers, Inc. (GeoEngineers) is pleased to submit this summary of our geological assessment completed in general accordance with City of Salem Revised Code Section 810.030(a) and (b) for the proposed Salem Cannery 6-Story Mixed-use Development located along Front Street NE between Belmont Street NE to Shipping Street NE in Salem, Oregon.

To perform the geological assessment, our scope included: reviewing geologic hazard maps and selected geotechnical and geological information about the site including our subsurface investigation, performing a geologic reconnaissance to observe surface conditions at the site and preparing this appendix providing a summary of our evaluation and conclusions and recommendations.

The site is located just east of the Willamette River and bounded by Shipping Street NE to the north, Mill Creek to the south, a flood plain of the Willamette River to the west and Front Street NE to the east. The site is relatively flat. However, adjacent slopes range from approximately 50 percent on the west side adjacent to the Willamette River and vertical where an existing gabion basket wall is located on the south side of the site adjacent to Mill Creek and a small flood plain of the Willamette River. Site surface conditions are described in further detail in the “Site Reconnaissance” section of this appendix.

Desktop Review

We completed a desktop review of the site prior to our site reconnaissance. Our desktop review included a landslide hazard risk assessment in accordance with the City of Salem revised code 810.025, geologic maps of the site, the Oregon Department of Geology and Mineral Industries (DOGAMI) Statewide Landslide Information Database for Oregon (SLIDO) (DOGAMI 2023) and a Light Detection and Ranging (LiDAR) hillshade model of the site (also viewed on the SLIDO).

Landslide Risk Assessment (SRC 810.025)

Based on our desktop review of the criteria in SRC 810.025 (a) and (b):

1. Table 810-1A (Earthquake-Induced Landslide Susceptibility Ratings [Hofmeister and Wang 2000]) requires review of IMS-17 and IMS-18. Most of the site is mapped as having a “Low” hazard rating. However, slopes within the property boundaries on the west and south sides of the site are mapped as the “Moderate” category. As such we assign **2 points** to the Earthquake Induced Landslide susceptibility rating.
2. Table 810-1B (Water-Induced Landslide Susceptibility Ratings [Harvey and Peterson 1998]) requires review of IMS-5, IMS-6 and IMS-22. The subject site is outside the study area boundary of IMS-5 and IMS-6 and is not mapped as a “potential landslide hazard zone” in IMS-22. However, Table 810-1B specifies that since the site is outside the mapped hazard area of IMS-5 and IMS-6 and is between 15 and 25 percent slopes, it must be assigned **2 points**.
3. Table 810-1C (Activity Susceptibility Ratings) – Since the project is planned for a multi-use development, we assumed it would classify as “installation or construction of any structure greater than 500 square feet in area” and would be considered a “multiple family building permit” in accordance with Table 810-C. Therefore we assigned **2 points** to the Activity Susceptibility Rating.

4. Table 810-1D (Cumulative Score) totals the cumulative score for the subject site. As we interpret the first three tables above, the cumulative score for the site is as follows: Step 1 (2 points) plus Step 2 (2 points) plus Step 3 (2 points) **Total = 6 points**

Per Table 810-1E (Total Landslide Hazard Risk), a cumulative score of 5 to 8 points falls under the moderate landslide hazard risk (Category B), which specifies that “...a geological assessment shall be submitted for all regulated activities. If the geological assessment indicates that mitigation measures are necessary to safely undertake the regulated activity, a geotechnical report prepared by a certified engineering geologist and geotechnical engineer shall be submitted.”

Geologic Mapping

See Section 3.2 Site Geology of the main body of this report. We note that Bela (1981) did not map any landslides at the site.

Landslide Hazard Mapping – SLIDO Review

Landslide mapping and landslide hazards for the site are compiled by the DOGAMI SLIDO (DOGAMI 2023). The SLIDO does not map landslides within the subject property, although it shows the western and southern slopes of the site as having a high regional landslide susceptibility.

LIDAR Hillshade Model Review

We reviewed a Light Detection and Ranging (LiDAR) bare earth hillshade model of the site on the SLIDO (DOGAMI 2023). We did not see obvious indications of landsliding within the site boundaries in the hillshade model.

Site Reconnaissance

We conducted a site reconnaissance on March 16, 2023. Most of the site is currently developed as an industrial cannery property with several buildings, paved parking and landscape areas, as shown on Figure 2. For the most part the development is located on the flat portion of the site between Front Street NE and slopes to the west and south. However, two of the buildings were constructed on the crest of and above the slope on the west side of the site. These buildings are founded on steel piles with the building floors above the slope. The remaining buildings appear to be founded on shallow foundations. We did not observe indications of slope movement within existing hardscape features (patio's, foundations, pavements) located on the flat portion of the site such as arcuate shaped ground cracks, significantly cracked foundations or sunken pavements.

The flat portion of the site is bounded to the west by an approximately 20- to 25-foot-high slope that terminates in a small flat floodplain of the Willamette River. In general, the slope is relatively planar and vegetated with a thick covering of blackberry and ivy and deciduous trees. We observed asphalt and concrete in portions of this slope indicating it is likely a fill slope associated with the existing development. An existing stormwater culvert daylight on this slope just north and west of the northernmost buildings, as shown on Figure 2. Stormwater flow from this culvert has eroded the slope resulting in a very steep to vertical approximately 8-foot-high slope on the south side of the culvert and undercutting of the concrete apron at the face of the culvert. Stormwater from this culvert currently falls about 5 feet between the concrete apron and asphalt/concrete/basalt boulder placed just below the apron.

The banks of the Willamette River (outside the site boundaries) are between approximately 4 and 8 feet high and vertical in many locations. Several deciduous trees are growing on these banks and just above them. We did not observe indications of recent or past landsliding on this slope, although thick blackberry cover precluded direct observation of the slopes' ground surface.

Mill Creek is located just south of the flat developed surface of the site. A gabion basket wall had been constructed on the southwest corner of the site. Ivy and blackberry was growing over the wall; however, we estimate the wall may be up to about 25 feet high. A portion of the wall on the southwest corner of the site failed resulting in an approximately 20-foot-high vertical slope. We observed gravel within the slope where the wall failed. The thalweg of Mill Creek is located on the north bank of the creek by this wall suggesting that creek erosion during flood conditions may have undercut the wall.

Geologic Hazard Conclusions

Based on our geologic hazard evaluation as presented herein, most of the slopes we observed surrounding the existing development appear relatively stable in their current configuration. However, the gabion wall on the south side of the site has failed indicating that the gabion wall, at least on the south side of the site adjacent to Mill Creek, is marginally stable. This wall likely failed because of erosion of the toe of the slope by Mill Creek. In our opinion, it would be beneficial to conduct a scour analysis to determine the likely future scour/migration of Mill Creek and how it would affect the proposed development.

A storm sewer outfall (assumed to be owned by the City of Salem) is actively eroding a portion of the slope bounding the west side of the site (see Figure 2). In our opinion, continued erosion around this outfall presents a moderate hazard of future erosion and/or landsliding adversely affecting the proposed development.

We recommend that development not encroach on any of the slopes surrounding the site. In addition, the planned development should not impart building loads on any of the site slopes and particularly the slopes in the southwest corner and south side of the site where the gabion walls are located. We recommend that new structures be placed sufficiently distant from top of slope or sufficiently deep as to maintain at least a 1.5H:1V (horizontal to vertical) set back from the base of the existing site slopes. We anticipate that the failed gabion wall will have to be mitigated in conjunction with construction of the proposed development. However, we recommend that development not alter the current configuration of the other slopes surrounding the site.

REFERENCES

- Harvey, A.F. and G.I. Peterson. 1998. Water Induced Landslide Hazards, Western Portion of the Salem Hills, Marion County, Oregon: Oregon Department of Geology and Mineral Industries, Interpretive Map Series IMS-6, 13p, 1 plate, 1:24,000 scale
- Hofmeister, J.R and Y. Wang. 2000. Earthquake Induced Slope Instability: Relative Hazard Map Western Portion of the Salem Hills, Marion County, Oregon: Oregon Department of Geology and Mineral Industries Interpretive Map Series IMS-17, 1 plate, 1:24,000 scale

Oregon Department of Geology and Mineral Industries (DOGAMI) 2023. Statewide Landslide Information Database for Oregon, Version 4.4, November 29, 2021. Accessed at <https://www.oregongeology.org/slido/> on March 17, 2023.

APPENDIX C
Report Limitations and Guidelines for Use

APPENDIX C

REPORT LIMITATIONS AND GUIDELINES FOR USE¹

This appendix provides information to help you manage your risks with respect to the use of this report.

Read These Provisions Closely

It is important to recognize that the geoscience practices (geotechnical engineering, geology and environmental science) rely on professional judgment and opinion to a greater extent than other engineering and natural science disciplines, where more precise and/or readily observable data may exist. To help clients better understand how this difference pertains to our services, GeoEngineers includes the following explanatory “limitations” provisions in its reports. Please confer with GeoEngineers if you need to know more about how these “Report Limitations and Guidelines for Use” apply to your project or site.

Geotechnical Services Are Performed for Specific Purposes, Persons and Projects

This report has been prepared for the Future of Neighborhood Development for the Project specifically identified in the report. The information contained herein is not applicable to other sites or projects.

GeoEngineers structures its services to meet the specific needs of its clients. No party other than the party to whom this report is addressed may rely on the product of our services unless we agree to such reliance in advance and in writing. Within the limitations of the agreed scope of services for the Project, and its schedule and budget, our services have been executed in accordance with our Agreement with the Future of Neighborhood Development and DAY CPM dated July 25, 2022 (authorized December 14, 2022) and generally accepted geotechnical practices in this area at the time this report was prepared. We do not authorize, and will not be responsible for, the use of this report for any purposes or projects other than those identified in the report.

A Geotechnical Engineering or Geologic Report is Based on a Unique Set of Project-Specific Factors

This report has been prepared for the Future of Neighborhood Development Salem Cannery 6-Story Mixed-use Development Project located at Front Street NE in Salem, Oregon. GeoEngineers considered a number of unique, project-specific factors when establishing the scope of services for this project and report. Unless GeoEngineers specifically indicates otherwise, it is important not to rely on this report if it was:

- Not prepared for you,
- Not prepared for your project,
- Not prepared for the specific site explored, or
- Completed before important project changes were made.

¹ Developed based on material provided by GBA, GeoProfessional Business Association; www.geoprofessional.org.

For example, changes that can affect the applicability of this report include those that affect:

- The function of the proposed structure;
- Elevation, configuration, location, orientation, or weight of the proposed structure;

If changes occur after the date of this report, GeoEngineers cannot be responsible for any consequences of such changes in relation to this report unless we have been given the opportunity to review our interpretations and recommendations. Based on that review, we can provide written modifications or confirmation, as appropriate.

Environmental Concerns Are Not Covered

Unless environmental services were specifically included in our scope of services, this report does not provide any environmental findings, conclusions, or recommendations, including but not limited to, the likelihood of encountering underground storage tanks or regulated contaminants.

Subsurface Conditions Can Change

This geotechnical or geologic report is based on conditions that existed at the time the study was performed. The findings and conclusions of this report may be affected by the passage of time, by man-made events such as construction on or adjacent to the site, new information or technology that becomes available subsequent to the report date, or by natural events such as floods, earthquakes, slope instability or groundwater fluctuations. If more than a few months have passed since issuance of our report or work product, or if any of the described events may have occurred, please contact GeoEngineers before applying this report for its intended purpose so that we may evaluate whether changed conditions affect the continued reliability or applicability of our conclusions and recommendations.

Geotechnical and Geologic Findings Are Professional Opinions

Our interpretations of subsurface conditions are based on field observations from widely spaced sampling locations at the site. Site exploration identifies the specific subsurface conditions only at those points where subsurface tests are conducted or samples are taken. GeoEngineers reviewed field and laboratory data and then applied its professional judgment to render an informed opinion about subsurface conditions at other locations. Actual subsurface conditions may differ, sometimes significantly, from the opinions presented in this report. Our report, conclusions and interpretations are not a warranty of the actual subsurface conditions.

Geotechnical Engineering Report Recommendations Are Not Final

We have developed the following recommendations based on data gathered from subsurface investigation(s). These investigations sample just a small percentage of a site to create a snapshot of the subsurface conditions elsewhere on the site. Such sampling on its own cannot provide a complete and accurate view of subsurface conditions for the entire site. Therefore, the recommendations included in this report are preliminary and should not be considered final. GeoEngineers' recommendations can be finalized only by observing actual subsurface conditions revealed during construction. GeoEngineers cannot assume responsibility or liability for the recommendations in this report if we do not perform construction observation.

We recommend that you allow sufficient monitoring, testing and consultation during construction by GeoEngineers to confirm that the conditions encountered are consistent with those indicated by the explorations, to provide recommendations for design changes if the conditions revealed during the work differ from those anticipated, and to evaluate whether earthwork activities are completed in accordance with our recommendations. Retaining GeoEngineers for construction observation for this project is the most effective means of managing the risks associated with unanticipated conditions. If another party performs field observation and confirms our expectations, the other party must take full responsibility for both the observations and recommendations. Please note, however, that another party would lack our project-specific knowledge and resources.

A Geotechnical Engineering or Geologic Report Could Be Subject to Misinterpretation

Misinterpretation of this report by members of the design team or by contractors can result in costly problems. GeoEngineers can help reduce the risks of misinterpretation by conferring with appropriate members of the design team after submitting the report, reviewing pertinent elements of the design team's plans and specifications, participating in pre-bid and preconstruction conferences, and providing construction observation.

Do Not Redraw the Exploration Logs

Geotechnical engineers and geologists prepare final boring and testing logs based upon their interpretation of field logs and laboratory data. The logs included in a geotechnical engineering or geologic report should never be redrawn for inclusion in architectural or other design drawings. Photographic or electronic reproduction is acceptable but separating logs from the report can create a risk of misinterpretation.

Give Contractors a Complete Report and Guidance

To help reduce the risk of problems associated with unanticipated subsurface conditions, GeoEngineers recommends giving contractors the complete geotechnical engineering or geologic report, including these "Report Limitations and Guidelines for Use." When providing the report, you should preface it with a clearly written letter of transmittal that:

- Advises contractors that the report was not prepared for purposes of bid development and that its accuracy is limited; and
- Encourages contractors to confer with GeoEngineers and/or to conduct additional study to obtain the specific types of information they need or prefer.

Contractors Are Responsible for Site Safety on Their Own Construction Projects

Our geotechnical recommendations are not intended to direct the contractor's procedures, methods, schedule or management of the work site. The contractor is solely responsible for job site safety and for managing construction operations to minimize risks to on-site personnel and adjacent properties.

Biological Pollutants

GeoEngineers' Scope of Work specifically excludes the investigation, detection, prevention or assessment of the presence of Biological Pollutants. Accordingly, this report does not include any interpretations, recommendations, findings or conclusions regarding the detecting, assessing, preventing or abating of Biological Pollutants, and no conclusions or inferences should be drawn regarding Biological Pollutants as

they may relate to this project. The term “Biological Pollutants” includes, but is not limited to, molds, fungi, spores, bacteria and viruses, and/or any of their byproducts.

A Client that desires these specialized services is advised to obtain them from a consultant who offers services in this specialized field.

Appendix B: NRCS Soil Resource Web Survey Results



United States
Department of
Agriculture

NRCS

Natural
Resources
Conservation
Service

A product of the National
Cooperative Soil Survey,
a joint effort of the United
States Department of
Agriculture and other
Federal agencies, State
agencies including the
Agricultural Experiment
Stations, and local
participants

Custom Soil Resource Report for Marion County Area, Oregon



Preface

Soil surveys contain information that affects land use planning in survey areas. They highlight soil limitations that affect various land uses and provide information about the properties of the soils in the survey areas. Soil surveys are designed for many different users, including farmers, ranchers, foresters, agronomists, urban planners, community officials, engineers, developers, builders, and home buyers. Also, conservationists, teachers, students, and specialists in recreation, waste disposal, and pollution control can use the surveys to help them understand, protect, or enhance the environment.

Various land use regulations of Federal, State, and local governments may impose special restrictions on land use or land treatment. Soil surveys identify soil properties that are used in making various land use or land treatment decisions. The information is intended to help the land users identify and reduce the effects of soil limitations on various land uses. The landowner or user is responsible for identifying and complying with existing laws and regulations.

Although soil survey information can be used for general farm, local, and wider area planning, onsite investigation is needed to supplement this information in some cases. Examples include soil quality assessments (<http://www.nrcs.usda.gov/wps/portal/nrcs/main/soils/health/>) and certain conservation and engineering applications. For more detailed information, contact your local USDA Service Center (<https://offices.sc.egov.usda.gov/locator/app?agency=nrcs>) or your NRCS State Soil Scientist (http://www.nrcs.usda.gov/wps/portal/nrcs/detail/soils/contactus/?cid=nrcs142p2_053951).

Great differences in soil properties can occur within short distances. Some soils are seasonally wet or subject to flooding. Some are too unstable to be used as a foundation for buildings or roads. Clayey or wet soils are poorly suited to use as septic tank absorption fields. A high water table makes a soil poorly suited to basements or underground installations.

The National Cooperative Soil Survey is a joint effort of the United States Department of Agriculture and other Federal agencies, State agencies including the Agricultural Experiment Stations, and local agencies. The Natural Resources Conservation Service (NRCS) has leadership for the Federal part of the National Cooperative Soil Survey.

Information about soils is updated periodically. Updated information is available through the NRCS Web Soil Survey, the site for official soil survey information.

The U.S. Department of Agriculture (USDA) prohibits discrimination in all its programs and activities on the basis of race, color, national origin, age, disability, and where applicable, sex, marital status, familial status, parental status, religion, sexual orientation, genetic information, political beliefs, reprisal, or because all or a part of an individual's income is derived from any public assistance program. (Not all prohibited bases apply to all programs.) Persons with disabilities who require

alternative means for communication of program information (Braille, large print, audiotape, etc.) should contact USDA's TARGET Center at (202) 720-2600 (voice and TDD). To file a complaint of discrimination, write to USDA, Director, Office of Civil Rights, 1400 Independence Avenue, S.W., Washington, D.C. 20250-9410 or call (800) 795-3272 (voice) or (202) 720-6382 (TDD). USDA is an equal opportunity provider and employer.

Contents

Preface	2
Soil Map	5
Soil Map.....	6
Legend.....	7
Map Unit Legend.....	8
Map Unit Descriptions.....	8
Marion County Area, Oregon.....	10
Ch—Chehalis silty clay loam.....	10
Te—Terrace escarpments.....	11
WuA—Woodburn silt loam, 0 to 3 percent slopes.....	11
Soil Information for All Uses	13
Soil Reports.....	13
Soil Physical Properties.....	13
Engineering Properties.....	13
References	17

Soil Map

The soil map section includes the soil map for the defined area of interest, a list of soil map units on the map and extent of each map unit, and cartographic symbols displayed on the map. Also presented are various metadata about data used to produce the map, and a description of each soil map unit.

Custom Soil Resource Report Soil Map

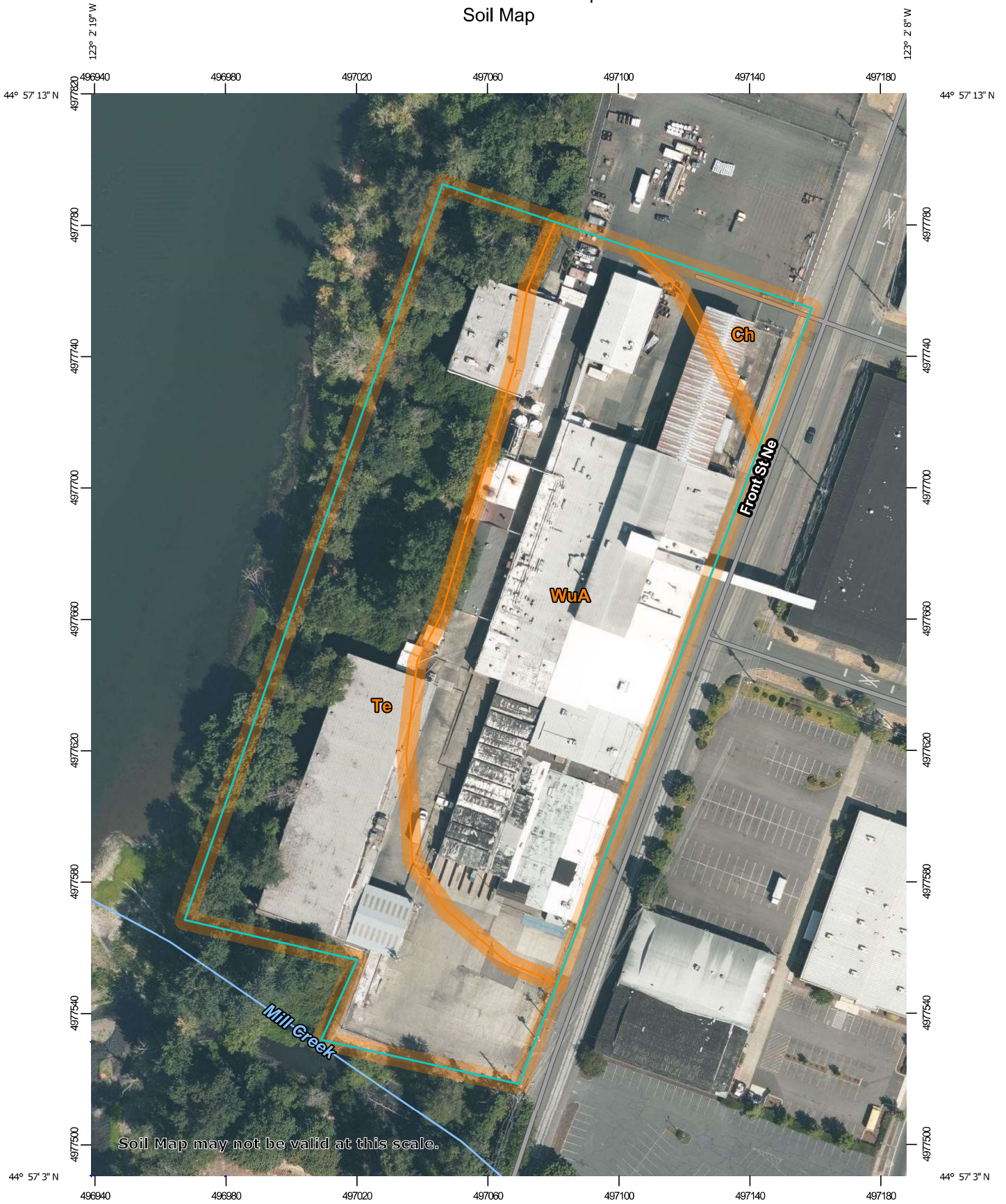

Soil Map may not be valid at this scale.

Map Scale: 1:1,600 if printed on A portrait (8.5" x 11") sheet.

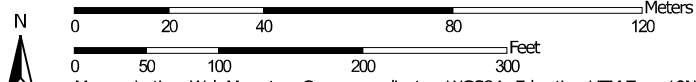

Map projection: Web Mercator Corner coordinates: WGS84 Edge tics: UTM Zone 10N WGS84

Custom Soil Resource Report

MAP LEGEND

Area of Interest (AOI)

 Area of Interest (AOI)

Soils

 Soil Map Unit Polygons

 Soil Map Unit Lines

 Soil Map Unit Points

Special Point Features

 Blowout

 Borrow Pit

 Clay Spot

 Closed Depression

 Gravel Pit

 Gravelly Spot

 Landfill

 Lava Flow

 Marsh or swamp

 Mine or Quarry

 Miscellaneous Water

 Perennial Water

 Rock Outcrop

 Saline Spot

 Sandy Spot

 Severely Eroded Spot

 Sinkhole

 Slide or Slip

 Sodic Spot

 Spoil Area

 Stony Spot

 Very Stony Spot

 Wet Spot

 Other

 Special Line Features

Water Features

 Streams and Canals

Transportation

 Rails

 Interstate Highways

 US Routes

 Major Roads

 Local Roads

Background

 Aerial Photography

MAP INFORMATION

The soil surveys that comprise your AOI were mapped at 1:20,000.

Warning: Soil Map may not be valid at this scale.

Enlargement of maps beyond the scale of mapping can cause misunderstanding of the detail of mapping and accuracy of soil line placement. The maps do not show the small areas of contrasting soils that could have been shown at a more detailed scale.

Please rely on the bar scale on each map sheet for map measurements.

Source of Map: Natural Resources Conservation Service
Web Soil Survey URL:
Coordinate System: Web Mercator (EPSG:3857)

Maps from the Web Soil Survey are based on the Web Mercator projection, which preserves direction and shape but distorts distance and area. A projection that preserves area, such as the Albers equal-area conic projection, should be used if more accurate calculations of distance or area are required.

This product is generated from the USDA-NRCS certified data as of the version date(s) listed below.

Soil Survey Area: Marion County Area, Oregon
Survey Area Data: Version 21, Sep 8, 2023

Soil map units are labeled (as space allows) for map scales 1:50,000 or larger.

Date(s) aerial images were photographed: Aug 1, 2018—Aug 31, 2018

The orthophoto or other base map on which the soil lines were compiled and digitized probably differs from the background imagery displayed on these maps. As a result, some minor shifting of map unit boundaries may be evident.

Map Unit Legend

Map Unit Symbol	Map Unit Name	Acres in AOI	Percent of AOI
Ch	Chehalis silty clay loam	0.3	3.7%
Te	Terrace escarpments	3.2	45.7%
WuA	Woodburn silt loam, 0 to 3 percent slopes	3.6	50.6%
Totals for Area of Interest		7.1	100.0%

Map Unit Descriptions

The map units delineated on the detailed soil maps in a soil survey represent the soils or miscellaneous areas in the survey area. The map unit descriptions, along with the maps, can be used to determine the composition and properties of a unit.

A map unit delineation on a soil map represents an area dominated by one or more major kinds of soil or miscellaneous areas. A map unit is identified and named according to the taxonomic classification of the dominant soils. Within a taxonomic class there are precisely defined limits for the properties of the soils. On the landscape, however, the soils are natural phenomena, and they have the characteristic variability of all natural phenomena. Thus, the range of some observed properties may extend beyond the limits defined for a taxonomic class. Areas of soils of a single taxonomic class rarely, if ever, can be mapped without including areas of other taxonomic classes. Consequently, every map unit is made up of the soils or miscellaneous areas for which it is named and some minor components that belong to taxonomic classes other than those of the major soils.

Most minor soils have properties similar to those of the dominant soil or soils in the map unit, and thus they do not affect use and management. These are called noncontrasting, or similar, components. They may or may not be mentioned in a particular map unit description. Other minor components, however, have properties and behavioral characteristics divergent enough to affect use or to require different management. These are called contrasting, or dissimilar, components. They generally are in small areas and could not be mapped separately because of the scale used. Some small areas of strongly contrasting soils or miscellaneous areas are identified by a special symbol on the maps. If included in the database for a given area, the contrasting minor components are identified in the map unit descriptions along with some characteristics of each. A few areas of minor components may not have been observed, and consequently they are not mentioned in the descriptions, especially where the pattern was so complex that it was impractical to make enough observations to identify all the soils and miscellaneous areas on the landscape.

The presence of minor components in a map unit in no way diminishes the usefulness or accuracy of the data. The objective of mapping is not to delineate pure taxonomic classes but rather to separate the landscape into landforms or landform segments that have similar use and management requirements. The delineation of such segments on the map provides sufficient information for the

Custom Soil Resource Report

development of resource plans. If intensive use of small areas is planned, however, onsite investigation is needed to define and locate the soils and miscellaneous areas.

An identifying symbol precedes the map unit name in the map unit descriptions. Each description includes general facts about the unit and gives important soil properties and qualities.

Soils that have profiles that are almost alike make up a *soil series*. Except for differences in texture of the surface layer, all the soils of a series have major horizons that are similar in composition, thickness, and arrangement.

Soils of one series can differ in texture of the surface layer, slope, stoniness, salinity, degree of erosion, and other characteristics that affect their use. On the basis of such differences, a soil series is divided into *soil phases*. Most of the areas shown on the detailed soil maps are phases of soil series. The name of a soil phase commonly indicates a feature that affects use or management. For example, Alpha silt loam, 0 to 2 percent slopes, is a phase of the Alpha series.

Some map units are made up of two or more major soils or miscellaneous areas. These map units are complexes, associations, or undifferentiated groups.

A *complex* consists of two or more soils or miscellaneous areas in such an intricate pattern or in such small areas that they cannot be shown separately on the maps. The pattern and proportion of the soils or miscellaneous areas are somewhat similar in all areas. Alpha-Beta complex, 0 to 6 percent slopes, is an example.

An *association* is made up of two or more geographically associated soils or miscellaneous areas that are shown as one unit on the maps. Because of present or anticipated uses of the map units in the survey area, it was not considered practical or necessary to map the soils or miscellaneous areas separately. The pattern and relative proportion of the soils or miscellaneous areas are somewhat similar. Alpha-Beta association, 0 to 2 percent slopes, is an example.

An *undifferentiated group* is made up of two or more soils or miscellaneous areas that could be mapped individually but are mapped as one unit because similar interpretations can be made for use and management. The pattern and proportion of the soils or miscellaneous areas in a mapped area are not uniform. An area can be made up of only one of the major soils or miscellaneous areas, or it can be made up of all of them. Alpha and Beta soils, 0 to 2 percent slopes, is an example.

Some surveys include *miscellaneous areas*. Such areas have little or no soil material and support little or no vegetation. Rock outcrop is an example.

Marion County Area, Oregon

Ch—Chehalis silty clay loam

Map Unit Setting

National map unit symbol: 24ny
Elevation: 100 to 650 feet
Mean annual precipitation: 40 to 45 inches
Mean annual air temperature: 52 to 54 degrees F
Frost-free period: 200 to 210 days
Farmland classification: All areas are prime farmland

Map Unit Composition

Chehalis and similar soils: 85 percent
Estimates are based on observations, descriptions, and transects of the mapunit.

Description of Chehalis

Setting

Landform: Flood plains
Landform position (three-dimensional): Tread
Down-slope shape: Linear
Across-slope shape: Linear
Parent material: Alluvium

Typical profile

H1 - 0 to 9 inches: silty clay loam
H2 - 9 to 80 inches: silty clay loam

Properties and qualities

Slope: 0 to 3 percent
Depth to restrictive feature: More than 80 inches
Drainage class: Well drained
Capacity of the most limiting layer to transmit water (Ksat): Moderately high to high
(0.57 to 1.98 in/hr)
Depth to water table: More than 80 inches
Frequency of flooding: Rare
Frequency of ponding: None
Available water supply, 0 to 60 inches: High (about 11.5 inches)

Interpretive groups

Land capability classification (irrigated): 1
Land capability classification (nonirrigated): 1
Hydrologic Soil Group: B
Ecological site: F002XC003OR - Low Flood Plain Group
Forage suitability group: Well drained < 15% Slopes (G002XY002OR)
Other vegetative classification: Well drained < 15% Slopes (G002XY002OR)
Hydric soil rating: No

Te—Terrace escarpments

Map Unit Setting

National map unit symbol: 24rp
Elevation: 50 to 1,000 feet
Mean annual precipitation: 40 to 60 inches
Mean annual air temperature: 50 to 54 degrees F
Frost-free period: 165 to 210 days
Farmland classification: Not prime farmland

Map Unit Composition

Terrace escarpments: 100 percent
Estimates are based on observations, descriptions, and transects of the mapunit.

Description of Terrace Escarpments

Typical profile

H1 - 0 to 8 inches: silt loam
H2 - 8 to 48 inches: gravelly loam
H3 - 48 to 60 inches: very cobbly clay loam

Properties and qualities

Slope: 20 to 40 percent
Drainage class: Well drained
Capacity of the most limiting layer to transmit water (Ksat): Moderately high (0.20 to 0.57 in/hr)
Depth to water table: About 36 to 72 inches
Available water supply, 0 to 60 inches: Moderate (about 8.0 inches)

Interpretive groups

Land capability classification (irrigated): None specified
Land capability classification (nonirrigated): 6e
Hydric soil rating: No

WuA—Woodburn silt loam, 0 to 3 percent slopes

Map Unit Setting

National map unit symbol: 24s3
Elevation: 150 to 350 feet
Mean annual precipitation: 40 to 45 inches
Mean annual air temperature: 52 to 54 degrees F
Frost-free period: 200 to 210 days
Farmland classification: All areas are prime farmland

Map Unit Composition

Woodburn and similar soils: 85 percent
Minor components: 1 percent

Custom Soil Resource Report

Estimates are based on observations, descriptions, and transects of the mapunit.

Description of Woodburn

Setting

Landform: Terraces

Landform position (three-dimensional): Tread

Down-slope shape: Linear

Across-slope shape: Linear

Parent material: Silty alluvium and mixed mineralogy loess

Typical profile

H1 - 0 to 17 inches: silt loam

H2 - 17 to 32 inches: silty clay loam

H3 - 32 to 68 inches: silt loam

Properties and qualities

Slope: 0 to 3 percent

Depth to restrictive feature: More than 80 inches

Drainage class: Moderately well drained

Capacity of the most limiting layer to transmit water (Ksat): Moderately low to moderately high (0.06 to 0.20 in/hr)

Depth to water table: About 25 to 32 inches

Frequency of flooding: None

Frequency of ponding: None

Available water supply, 0 to 60 inches: High (about 12.0 inches)

Interpretive groups

Land capability classification (irrigated): 2w

Land capability classification (nonirrigated): 2w

Hydrologic Soil Group: C

Ecological site: R002XC008OR - Valley Terrace Group

Forage suitability group: Moderately Well Drained < 15% Slopes (G002XY004OR)

Other vegetative classification: Moderately Well Drained < 15% Slopes (G002XY004OR)

Hydric soil rating: No

Minor Components

Aquolls, somewhat poorly drained

Percent of map unit: 1 percent

Landform: Terraces

Hydric soil rating: Yes

Soil Information for All Uses

Soil Reports

The Soil Reports section includes various formatted tabular and narrative reports (tables) containing data for each selected soil map unit and each component of each unit. No aggregation of data has occurred as is done in reports in the Soil Properties and Qualities and Suitabilities and Limitations sections.

The reports contain soil interpretive information as well as basic soil properties and qualities. A description of each report (table) is included.

Soil Physical Properties

This folder contains a collection of tabular reports that present soil physical properties. The reports (tables) include all selected map units and components for each map unit. Soil physical properties are measured or inferred from direct observations in the field or laboratory. Examples of soil physical properties include percent clay, organic matter, saturated hydraulic conductivity, available water capacity, and bulk density.

Engineering Properties

This table gives the engineering classifications and the range of engineering properties for the layers of each soil in the survey area.

Hydrologic soil group is a group of soils having similar runoff potential under similar storm and cover conditions. The criteria for determining Hydrologic soil group is found in the National Engineering Handbook, Chapter 7 issued May 2007(<http://directives.sc.egov.usda.gov/OpenNonWebContent.aspx?content=17757.wba>). Listing HSGs by soil map unit component and not by soil series is a new concept for the engineers. Past engineering references contained lists of HSGs by soil series. Soil series are continually being defined and redefined, and the list of soil series names changes so frequently as to make the task of maintaining a single national list virtually impossible. Therefore, the criteria is now used to calculate the HSG using the component soil properties and no such national series lists will be maintained. All such references are obsolete and their use should be discontinued. Soil properties that influence runoff potential are those that influence the minimum rate of infiltration for a bare soil after prolonged wetting and when not frozen. These properties are depth to a seasonal high water table, saturated hydraulic conductivity after prolonged wetting, and depth to a layer with a very slow water transmission

Custom Soil Resource Report

rate. Changes in soil properties caused by land management or climate changes also cause the hydrologic soil group to change. The influence of ground cover is treated independently. There are four hydrologic soil groups, A, B, C, and D, and three dual groups, A/D, B/D, and C/D. In the dual groups, the first letter is for drained areas and the second letter is for undrained areas.

The four hydrologic soil groups are described in the following paragraphs:

Group A. Soils having a high infiltration rate (low runoff potential) when thoroughly wet. These consist mainly of deep, well drained to excessively drained sands or gravelly sands. These soils have a high rate of water transmission.

Group B. Soils having a moderate infiltration rate when thoroughly wet. These consist chiefly of moderately deep or deep, moderately well drained or well drained soils that have moderately fine texture to moderately coarse texture. These soils have a moderate rate of water transmission.

Group C. Soils having a slow infiltration rate when thoroughly wet. These consist chiefly of soils having a layer that impedes the downward movement of water or soils of moderately fine texture or fine texture. These soils have a slow rate of water transmission.

Group D. Soils having a very slow infiltration rate (high runoff potential) when thoroughly wet. These consist chiefly of clays that have a high shrink-swell potential, soils that have a high water table, soils that have a claypan or clay layer at or near the surface, and soils that are shallow over nearly impervious material. These soils have a very slow rate of water transmission.

Depth to the upper and lower boundaries of each layer is indicated.

Texture is given in the standard terms used by the U.S. Department of Agriculture. These terms are defined according to percentages of sand, silt, and clay in the fraction of the soil that is less than 2 millimeters in diameter. "Loam," for example, is soil that is 7 to 27 percent clay, 28 to 50 percent silt, and less than 52 percent sand. If the content of particles coarser than sand is 15 percent or more, an appropriate modifier is added, for example, "gravelly."

Classification of the soils is determined according to the Unified soil classification system (ASTM, 2005) and the system adopted by the American Association of State Highway and Transportation Officials (AASHTO, 2004).

The Unified system classifies soils according to properties that affect their use as construction material. Soils are classified according to particle-size distribution of the fraction less than 3 inches in diameter and according to plasticity index, liquid limit, and organic matter content. Sandy and gravelly soils are identified as GW, GP, GM, GC, SW, SP, SM, and SC; silty and clayey soils as ML, CL, OL, MH, CH, and OH; and highly organic soils as PT. Soils exhibiting engineering properties of two groups can have a dual classification, for example, CL-ML.

The AASHTO system classifies soils according to those properties that affect roadway construction and maintenance. In this system, the fraction of a mineral soil that is less than 3 inches in diameter is classified in one of seven groups from A-1 through A-7 on the basis of particle-size distribution, liquid limit, and plasticity index. Soils in group A-1 are coarse grained and low in content of fines (silt and clay). At the other extreme, soils in group A-7 are fine grained. Highly organic soils are classified in group A-8 on the basis of visual inspection.

If laboratory data are available, the A-1, A-2, and A-7 groups are further classified as A-1-a, A-1-b, A-2-4, A-2-5, A-2-6, A-2-7, A-7-5, or A-7-6. As an additional refinement, the suitability of a soil as subgrade material can be indicated by a group

Custom Soil Resource Report

index number. Group index numbers range from 0 for the best subgrade material to 20 or higher for the poorest.

Percentage of rock fragments larger than 10 inches in diameter and 3 to 10 inches in diameter are indicated as a percentage of the total soil on a dry-weight basis. The percentages are estimates determined mainly by converting volume percentage in the field to weight percentage. Three values are provided to identify the expected Low (L), Representative Value (R), and High (H).

Percentage (of soil particles) passing designated sieves is the percentage of the soil fraction less than 3 inches in diameter based on an oven-dry weight. The sieves, numbers 4, 10, 40, and 200 (USA Standard Series), have openings of 4.76, 2.00, 0.420, and 0.074 millimeters, respectively. Estimates are based on laboratory tests of soils sampled in the survey area and in nearby areas and on estimates made in the field. Three values are provided to identify the expected Low (L), Representative Value (R), and High (H).

Liquid limit and plasticity index (Atterberg limits) indicate the plasticity characteristics of a soil. The estimates are based on test data from the survey area or from nearby areas and on field examination. Three values are provided to identify the expected Low (L), Representative Value (R), and High (H).

References:

- American Association of State Highway and Transportation Officials (AASHTO). 2004. Standard specifications for transportation materials and methods of sampling and testing. 24th edition.
- American Society for Testing and Materials (ASTM). 2005. Standard classification of soils for engineering purposes. ASTM Standard D2487-00.

Custom Soil Resource Report

Absence of an entry indicates that the data were not estimated. The asterisk "*" denotes the representative texture; other possible textures follow the dash. The criteria for determining the hydrologic soil group for individual soil components is found in the National Engineering Handbook, Chapter 7 issued May 2007(<http://directives.sc.egov.usda.gov/OpenNonWebContent.aspx?content=17757.wba>). Three values are provided to identify the expected Low (L), Representative Value (R), and High (H).

Engineering Properties—Marion County Area, Oregon														
Map unit symbol and soil name	Pct. of map unit	Hydrologic group	Depth	USDA texture	Classification		Pct Fragments		Percentage passing sieve number—				Liquid limit	Plasticity index
					Unified	AASHTO	>10 inches	3-10 inches	4	10	40	200		
			<i>In</i>				<i>L-R-H</i>	<i>L-R-H</i>	<i>L-R-H</i>	<i>L-R-H</i>	<i>L-R-H</i>	<i>L-R-H</i>	<i>L-R-H</i>	<i>L-R-H</i>
Ch—Chehalis silty clay loam														
Chehalis	85	B	0-9	Silty clay loam	CL	A-7	0- 0- 0	0- 0- 0	100-100-100	100-100-100	95-98-100	85-90-95	40-45-50	20-25-30
			9-80	Silt loam, silty clay loam	ML	A-4, A-5, A-6, A-7	0- 0- 0	0- 0- 0	100-100-100	100-100-100	95-98-100	85-90-95	35-40-45	5-10-15
Te—Terrace escarpments														
Terrace escarpments	100		0-8	Silt loam	CL-ML, CL, ML	A-4	0- 0- 0	0- 0- 0	85-93-100	75-88-100	70-83-95	65-75-85	25-30-35	5-8-10
			8-48	Gravelly loam, gravelly clay loam, silty clay loam	CL-ML, SC-SM, CL, ML, SC, SM	A-4	0- 0- 0	0- 3- 5	70-80-90	60-75-90	50-70-90	40-60-80	25-30-35	5-8-10
			48-60	Very cobbly clay loam	GC, GM, SC, SM	A-6	0- 0- 0	25-35-45	55-65-75	45-55-65	40-50-60	35-43-50	35-38-40	10-13-15
WuA—Woodburn silt loam, 0 to 3 percent slopes														
Woodburn	85	C	0-17	Silt loam	ML	A-4	0- 0- 0	0- 0- 0	100-100-100	95-98-100	85-90-95	70-78-85	25-28-30	NP-3-5
			17-32	Silty clay loam, silt loam	CL	A-6	0- 0- 0	0- 0- 0	100-100-100	100-100-100	95-98-100	85-90-95	30-35-40	10-15-20
			32-68	Silt loam, silty clay loam	CL-ML, CL, ML	A-4	0- 0- 0	0- 0- 0	100-100-100	100-100-100	95-98-100	80-85-90	25-30-35	5-8-10

References

- American Association of State Highway and Transportation Officials (AASHTO). 2004. Standard specifications for transportation materials and methods of sampling and testing. 24th edition.
- American Society for Testing and Materials (ASTM). 2005. Standard classification of soils for engineering purposes. ASTM Standard D2487-00.
- Cowardin, L.M., V. Carter, F.C. Golet, and E.T. LaRoe. 1979. Classification of wetlands and deep-water habitats of the United States. U.S. Fish and Wildlife Service FWS/OBS-79/31.
- Federal Register. July 13, 1994. Changes in hydric soils of the United States.
- Federal Register. September 18, 2002. Hydric soils of the United States.
- Hurt, G.W., and L.M. Vasilas, editors. Version 6.0, 2006. Field indicators of hydric soils in the United States.
- National Research Council. 1995. Wetlands: Characteristics and boundaries.
- Soil Survey Division Staff. 1993. Soil survey manual. Soil Conservation Service. U.S. Department of Agriculture Handbook 18. http://www.nrcs.usda.gov/wps/portal/nrcs/detail/national/soils/?cid=nrcs142p2_054262
- Soil Survey Staff. 1999. Soil taxonomy: A basic system of soil classification for making and interpreting soil surveys. 2nd edition. Natural Resources Conservation Service, U.S. Department of Agriculture Handbook 436. http://www.nrcs.usda.gov/wps/portal/nrcs/detail/national/soils/?cid=nrcs142p2_053577
- Soil Survey Staff. 2010. Keys to soil taxonomy. 11th edition. U.S. Department of Agriculture, Natural Resources Conservation Service. http://www.nrcs.usda.gov/wps/portal/nrcs/detail/national/soils/?cid=nrcs142p2_053580
- Tiner, R.W., Jr. 1985. Wetlands of Delaware. U.S. Fish and Wildlife Service and Delaware Department of Natural Resources and Environmental Control, Wetlands Section.
- United States Army Corps of Engineers, Environmental Laboratory. 1987. Corps of Engineers wetlands delineation manual. Waterways Experiment Station Technical Report Y-87-1.
- United States Department of Agriculture, Natural Resources Conservation Service. National forestry manual. http://www.nrcs.usda.gov/wps/portal/nrcs/detail/soils/home/?cid=nrcs142p2_053374
- United States Department of Agriculture, Natural Resources Conservation Service. National range and pasture handbook. <http://www.nrcs.usda.gov/wps/portal/nrcs/detail/national/landuse/rangepasture/?cid=stelprdb1043084>

Custom Soil Resource Report

United States Department of Agriculture, Natural Resources Conservation Service. National soil survey handbook, title 430-VI. http://www.nrcs.usda.gov/wps/portal/nrcs/detail/soils/scientists/?cid=nrcs142p2_054242

United States Department of Agriculture, Natural Resources Conservation Service. 2006. Land resource regions and major land resource areas of the United States, the Caribbean, and the Pacific Basin. U.S. Department of Agriculture Handbook 296. http://www.nrcs.usda.gov/wps/portal/nrcs/detail/national/soils/?cid=nrcs142p2_053624

United States Department of Agriculture, Soil Conservation Service. 1961. Land capability classification. U.S. Department of Agriculture Handbook 210. http://www.nrcs.usda.gov/Internet/FSE_DOCUMENTS/nrcs142p2_052290.pdf

Appendix C: HydroCAD Analysis

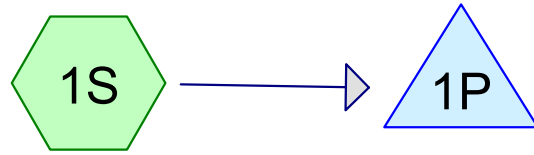

BLDG 1

Planter 1

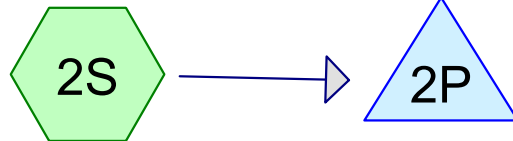

BLDG 2

Planter 2

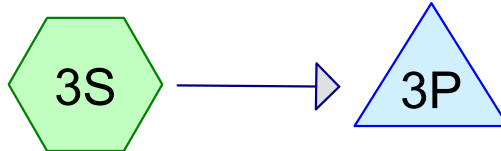

BLDG 3

Planter 3

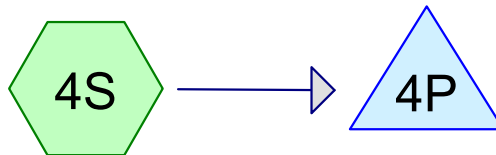

Basin 4

Pond 4

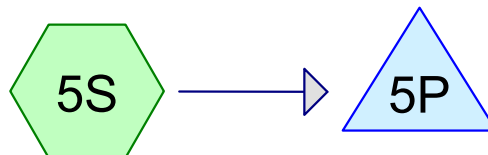

Basin 5

Pond 5

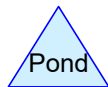
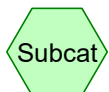

Summary for Subcatchment 1S: BLDG 1

Runoff = 0.31 cfs @ 7.89 hrs, Volume= 0.099 af, Depth= 1.16"

Runoff by SCS TR-20 method, UH=SCS, Weighted-CN, Time Span= 0.00-50.00 hrs, dt= 0.05 hrs
Type IA 24-hr WQ Rainfall=1.38"

Area (sf)	CN	Description
44,539	98	Paved parking, HSG C
44,539		100.00% Impervious Area

Tc (min)	Length (feet)	Slope (ft/ft)	Velocity (ft/sec)	Capacity (cfs)	Description
6.0					Direct Entry,

Summary for Pond 1P: Planter 1

Inflow Area = 1.022 ac, 100.00% Impervious, Inflow Depth = 1.16" for WQ event
 Inflow = 0.31 cfs @ 7.89 hrs, Volume= 0.099 af
 Outflow = 0.05 cfs @ 5.55 hrs, Volume= 0.099 af, Atten= 84%, Lag= 0.0 min
 Primary = 0.05 cfs @ 5.55 hrs, Volume= 0.099 af

Routing by Stor-Ind method, Time Span= 0.00-50.00 hrs, dt= 0.05 hrs
 Peak Elev= 146.48' @ 12.63 hrs Surf.Area= 1,100 sf Storage= 1,077 cf

Plug-Flow detention time= 222.5 min calculated for 0.099 af (100% of inflow)
 Center-of-Mass det. time= 222.5 min (918.8 - 696.3)

Volume	Invert	Avail.Storage	Storage Description
#1	145.50'	1,925 cf	Custom Stage Data (Prismatic) Listed below (Recalc)

Elevation (feet)	Surf.Area (sq-ft)	Inc.Store (cubic-feet)	Cum.Store (cubic-feet)
145.50	1,100	0	0
147.25	1,100	1,925	1,925

Device	Routing	Invert	Outlet Devices
#1	Device 2	145.50'	2.000 in/hr Exfiltration over Surface area
#2	Primary	142.75'	6.0" Vert. Outlet C= 0.600
#3	Device 2	146.55'	24.0" Horiz. 24" Beehive Overflow C= 0.600 Limited to weir flow at low heads

Primary OutFlow Max=0.05 cfs @ 5.55 hrs HW=145.52' (Free Discharge)

- ↑ 2=Outlet (Passes 0.05 cfs of 1.50 cfs potential flow)
- ↑ 1=Exfiltration (Exfiltration Controls 0.05 cfs)
- ↑ 3=24" Beehive Overflow (Controls 0.00 cfs)

Summary for Subcatchment 1S: BLDG 1

Runoff = 1.08 cfs @ 7.87 hrs, Volume= 0.355 af, Depth= 4.16"

Runoff by SCS TR-20 method, UH=SCS, Weighted-CN, Time Span= 0.00-50.00 hrs, dt= 0.05 hrs
Type IA 24-hr 100-yr Rainfall=4.40"

Area (sf)	CN	Description
44,539	98	Paved parking, HSG C
44,539		100.00% Impervious Area

Tc (min)	Length (feet)	Slope (ft/ft)	Velocity (ft/sec)	Capacity (cfs)	Description
6.0					Direct Entry,

Summary for Pond 1P: Planter 1

Inflow Area = 1.022 ac, 100.00% Impervious, Inflow Depth = 4.16" for 100-yr event
 Inflow = 1.08 cfs @ 7.87 hrs, Volume= 0.355 af
 Outflow = 1.07 cfs @ 7.90 hrs, Volume= 0.355 af, Atten= 0%, Lag= 1.7 min
 Primary = 1.07 cfs @ 7.90 hrs, Volume= 0.355 af

Routing by Stor-Ind method, Time Span= 0.00-50.00 hrs, dt= 0.05 hrs
 Peak Elev= 146.69' @ 7.90 hrs Surf.Area= 1,100 sf Storage= 1,304 cf

Plug-Flow detention time= 108.7 min calculated for 0.355 af (100% of inflow)
 Center-of-Mass det. time= 108.6 min (766.2 - 657.6)

Volume	Invert	Avail.Storage	Storage Description
#1	145.50'	1,925 cf	Custom Stage Data (Prismatic) Listed below (Recalc)

Elevation (feet)	Surf.Area (sq-ft)	Inc.Store (cubic-feet)	Cum.Store (cubic-feet)
145.50	1,100	0	0
147.25	1,100	1,925	1,925

Device	Routing	Invert	Outlet Devices
#1	Device 2	145.50'	2.000 in/hr Exfiltration over Surface area
#2	Primary	142.75'	6.0" Vert. Outlet C= 0.600
#3	Device 2	146.55'	24.0" Horiz. 24" Beehive Overflow C= 0.600 Limited to weir flow at low heads

Primary OutFlow Max=1.07 cfs @ 7.90 hrs HW=146.69' (Free Discharge)

- ↑ **2=Outlet** (Passes 1.07 cfs of 1.81 cfs potential flow)
- ↑ **1=Exfiltration** (Exfiltration Controls 0.05 cfs)
- ↑ **3=24" Beehive Overflow** (Weir Controls 1.02 cfs @ 1.20 fps)

Summary for Subcatchment 2S: BLDG 2

Runoff = 0.25 cfs @ 7.89 hrs, Volume= 0.079 af, Depth= 1.16"

Runoff by SCS TR-20 method, UH=SCS, Weighted-CN, Time Span= 0.00-50.00 hrs, dt= 0.05 hrs
Type IA 24-hr WQ Rainfall=1.38"

Area (sf)	CN	Description
35,385	98	Paved parking, HSG C
35,385		100.00% Impervious Area

Tc (min)	Length (feet)	Slope (ft/ft)	Velocity (ft/sec)	Capacity (cfs)	Description
6.0					Direct Entry,

Summary for Pond 2P: Planter 2

Inflow Area = 0.812 ac, 100.00% Impervious, Inflow Depth = 1.16" for WQ event
 Inflow = 0.25 cfs @ 7.89 hrs, Volume= 0.079 af
 Outflow = 0.05 cfs @ 5.95 hrs, Volume= 0.079 af, Atten= 82%, Lag= 0.0 min
 Primary = 0.05 cfs @ 5.95 hrs, Volume= 0.079 af

Routing by Stor-Ind method, Time Span= 0.00-50.00 hrs, dt= 0.05 hrs
 Peak Elev= 145.27' @ 11.40 hrs Surf.Area= 975 sf Storage= 752 cf

Plug-Flow detention time= 161.3 min calculated for 0.079 af (100% of inflow)
 Center-of-Mass det. time= 161.2 min (857.5 - 696.3)

Volume	Invert	Avail.Storage	Storage Description
#1	144.50'	1,463 cf	Custom Stage Data (Prismatic) Listed below (Recalc)

Elevation (feet)	Surf.Area (sq-ft)	Inc.Store (cubic-feet)	Cum.Store (cubic-feet)
144.50	975	0	0
146.00	975	1,463	1,463

Device	Routing	Invert	Outlet Devices
#1	Primary	141.75'	6.0" Vert. 6" Outlet Pipe C= 0.600
#2	Device 1	144.50'	2.000 in/hr Exfiltration over Surface area
#3	Primary	145.35'	24.0" Horiz. Beehive Overflow C= 0.600 Limited to weir flow at low heads

Primary OutFlow Max=0.05 cfs @ 5.95 hrs HW=144.52' (Free Discharge)
 1=6" Outlet Pipe (Passes 0.05 cfs of 1.50 cfs potential flow)
 2=Exfiltration (Exfiltration Controls 0.05 cfs)
 3=Beehive Overflow (Controls 0.00 cfs)

Summary for Subcatchment 2S: BLDG 2

Runoff = 0.85 cfs @ 7.87 hrs, Volume= 0.282 af, Depth= 4.16"

Runoff by SCS TR-20 method, UH=SCS, Weighted-CN, Time Span= 0.00-50.00 hrs, dt= 0.05 hrs
Type IA 24-hr 100-yr Rainfall=4.40"

Area (sf)	CN	Description
35,385	98	Paved parking, HSG C
35,385		100.00% Impervious Area

Tc (min)	Length (feet)	Slope (ft/ft)	Velocity (ft/sec)	Capacity (cfs)	Description
6.0					Direct Entry,

Summary for Pond 2P: Planter 2

Inflow Area = 0.812 ac, 100.00% Impervious, Inflow Depth = 4.16" for 100-yr event
 Inflow = 0.85 cfs @ 7.87 hrs, Volume= 0.282 af
 Outflow = 0.85 cfs @ 7.90 hrs, Volume= 0.282 af, Atten= 0%, Lag= 1.6 min
 Primary = 0.85 cfs @ 7.90 hrs, Volume= 0.282 af

Routing by Stor-Ind method, Time Span= 0.00-50.00 hrs, dt= 0.05 hrs
 Peak Elev= 145.47' @ 7.90 hrs Surf.Area= 975 sf Storage= 941 cf

Plug-Flow detention time= 95.7 min calculated for 0.282 af (100% of inflow)
 Center-of-Mass det. time= 95.7 min (753.3 - 657.6)

Volume	Invert	Avail.Storage	Storage Description
#1	144.50'	1,463 cf	Custom Stage Data (Prismatic) Listed below (Recalc)

Elevation (feet)	Surf.Area (sq-ft)	Inc.Store (cubic-feet)	Cum.Store (cubic-feet)
144.50	975	0	0
146.00	975	1,463	1,463

Device	Routing	Invert	Outlet Devices
#1	Primary	141.75'	6.0" Vert. 6" Outlet Pipe C= 0.600
#2	Device 1	144.50'	2.000 in/hr Exfiltration over Surface area
#3	Primary	145.35'	24.0" Horiz. Beehive Overflow C= 0.600 Limited to weir flow at low heads

Primary OutFlow Max=0.85 cfs @ 7.90 hrs HW=145.47' (Free Discharge)
 1=6" Outlet Pipe (Passes 0.05 cfs of 1.76 cfs potential flow)
 2=Exfiltration (Exfiltration Controls 0.05 cfs)
 3=Beehive Overflow (Weir Controls 0.81 cfs @ 1.11 fps)

Summary for Subcatchment 3S: BLDG 3

Runoff = 0.31 cfs @ 7.89 hrs, Volume= 0.097 af, Depth= 1.16"

Runoff by SCS TR-20 method, UH=SCS, Weighted-CN, Time Span= 0.00-50.00 hrs, dt= 0.05 hrs
Type IA 24-hr WQ Rainfall=1.38"

Area (sf)	CN	Description
43,849	98	Paved parking, HSG C
43,849		100.00% Impervious Area

Tc (min)	Length (feet)	Slope (ft/ft)	Velocity (ft/sec)	Capacity (cfs)	Description
6.0					Direct Entry,

Summary for Pond 3P: Planter 3

Inflow Area = 1.007 ac, 100.00% Impervious, Inflow Depth = 1.16" for WQ event
 Inflow = 0.31 cfs @ 7.89 hrs, Volume= 0.097 af
 Outflow = 0.05 cfs @ 5.30 hrs, Volume= 0.097 af, Atten= 85%, Lag= 0.0 min
 Primary = 0.05 cfs @ 5.30 hrs, Volume= 0.097 af

Routing by Stor-Ind method, Time Span= 0.00-50.00 hrs, dt= 0.05 hrs
 Peak Elev= 145.17' @ 13.77 hrs Surf.Area= 1,000 sf Storage= 1,172 cf

Plug-Flow detention time= 273.2 min calculated for 0.097 af (100% of inflow)
 Center-of-Mass det. time= 273.2 min (969.6 - 696.3)

Volume	Invert	Avail.Storage	Storage Description
#1	144.00'	2,000 cf	Custom Stage Data (Prismatic) Listed below (Recalc)

Elevation (feet)	Surf.Area (sq-ft)	Inc.Store (cubic-feet)	Cum.Store (cubic-feet)
144.00	1,000	0	0
146.00	1,000	2,000	2,000

Device	Routing	Invert	Outlet Devices
#1	Device 2	144.00'	2.000 in/hr Exfiltration over Surface area
#2	Primary	141.25'	6.0" Vert. Outlet C= 0.600
#3	Primary	145.25'	24.0" Horiz. Beehive Overflow C= 0.600 Limited to weir flow at low heads

Primary OutFlow Max=0.05 cfs @ 5.30 hrs HW=144.02' (Free Discharge)

- 2=Outlet (Passes 0.05 cfs of 1.50 cfs potential flow)
- 1=Exfiltration (Exfiltration Controls 0.05 cfs)
- 3=Beehive Overflow (Controls 0.00 cfs)

Summary for Subcatchment 3S: BLDG 3

Runoff = 1.06 cfs @ 7.87 hrs, Volume= 0.349 af, Depth= 4.16"

Runoff by SCS TR-20 method, UH=SCS, Weighted-CN, Time Span= 0.00-50.00 hrs, dt= 0.05 hrs
Type IA 24-hr 100-yr Rainfall=4.40"

Area (sf)	CN	Description
43,849	98	Paved parking, HSG C
43,849		100.00% Impervious Area

Tc (min)	Length (feet)	Slope (ft/ft)	Velocity (ft/sec)	Capacity (cfs)	Description
6.0					Direct Entry,

Summary for Pond 3P: Planter 3

Inflow Area = 1.007 ac, 100.00% Impervious, Inflow Depth = 4.16" for 100-yr event
 Inflow = 1.06 cfs @ 7.87 hrs, Volume= 0.349 af
 Outflow = 1.06 cfs @ 7.90 hrs, Volume= 0.349 af, Atten= 0%, Lag= 1.5 min
 Primary = 1.06 cfs @ 7.90 hrs, Volume= 0.349 af

Routing by Stor-Ind method, Time Span= 0.00-50.00 hrs, dt= 0.05 hrs
 Peak Elev= 145.38' @ 7.90 hrs Surf.Area= 1,000 sf Storage= 1,384 cf

Plug-Flow detention time= 121.7 min calculated for 0.349 af (100% of inflow)
 Center-of-Mass det. time= 121.7 min (779.3 - 657.6)

Volume	Invert	Avail.Storage	Storage Description
#1	144.00'	2,000 cf	Custom Stage Data (Prismatic) Listed below (Recalc)
Elevation (feet)	Surf.Area (sq-ft)	Inc.Store (cubic-feet)	Cum.Store (cubic-feet)
144.00	1,000	0	0
146.00	1,000	2,000	2,000

Device	Routing	Invert	Outlet Devices
#1	Device 2	144.00'	2.000 in/hr Exfiltration over Surface area
#2	Primary	141.25'	6.0" Vert. Outlet C= 0.600
#3	Primary	145.25'	24.0" Horiz. Beehive Overflow C= 0.600 Limited to weir flow at low heads

Primary OutFlow Max=1.06 cfs @ 7.90 hrs HW=145.38' (Free Discharge)
 2=Outlet (Passes 0.05 cfs of 1.86 cfs potential flow)
 1=Exfiltration (Exfiltration Controls 0.05 cfs)
 3=Beehive Overflow (Weir Controls 1.01 cfs @ 1.20 fps)

Summary for Subcatchment 4S: Basin 4

Runoff = 0.22 cfs @ 7.89 hrs, Volume= 0.069 af, Depth= 1.16"

Runoff by SCS TR-20 method, UH=SCS, Weighted-CN, Time Span= 0.00-50.00 hrs, dt= 0.05 hrs
Type IA 24-hr WQ Rainfall=1.38"

Area (sf)	CN	Description
31,106	98	Paved parking, HSG C
31,106		100.00% Impervious Area

Tc (min)	Length (feet)	Slope (ft/ft)	Velocity (ft/sec)	Capacity (cfs)	Description
6.0					Direct Entry, Direct Entry

Summary for Pond 4P: Pond 4

Inflow Area = 0.714 ac, 100.00% Impervious, Inflow Depth = 1.16" for WQ event
 Inflow = 0.22 cfs @ 7.89 hrs, Volume= 0.069 af
 Outflow = 0.03 cfs @ 4.75 hrs, Volume= 0.069 af, Atten= 88%, Lag= 0.0 min
 Primary = 0.03 cfs @ 4.75 hrs, Volume= 0.069 af

Routing by Stor-Ind method, Time Span= 0.00-50.00 hrs, dt= 0.05 hrs
 Peak Elev= 142.63' @ 19.39 hrs Surf.Area= 545 sf Storage= 1,163 cf

Plug-Flow detention time= 483.0 min calculated for 0.069 af (100% of inflow)
 Center-of-Mass det. time= 483.3 min (1,179.6 - 696.3)

Volume	Invert	Avail.Storage	Storage Description
#1	140.50'	2,126 cf	Custom Stage Data (Prismatic) Listed below (Recalc)

Elevation (feet)	Surf.Area (sq-ft)	Inc.Store (cubic-feet)	Cum.Store (cubic-feet)
140.50	545	0	0
144.40	545	2,126	2,126

Device	Routing	Invert	Outlet Devices
#1	Device 2	140.50'	2.000 in/hr Exfiltration over Surface area
#2	Primary	137.75'	8.0" Vert. 8" Outlet C= 0.600
#3	Primary	142.70'	24.0" Horiz. Beehive Overflow C= 0.600 Limited to weir flow at low heads

Primary OutFlow Max=0.03 cfs @ 4.75 hrs HW=140.54' (Free Discharge)
 2=8" Outlet (Passes 0.03 cfs of 2.63 cfs potential flow)
 1=Exfiltration (Exfiltration Controls 0.03 cfs)
 3=Beehive Overflow (Controls 0.00 cfs)

Summary for Subcatchment 4S: Basin 4

Runoff = 0.75 cfs @ 7.87 hrs, Volume= 0.248 af, Depth= 4.16"

Runoff by SCS TR-20 method, UH=SCS, Weighted-CN, Time Span= 0.00-50.00 hrs, dt= 0.05 hrs
Type IA 24-hr 100-yr Rainfall=4.40"

Area (sf)	CN	Description
31,106	98	Paved parking, HSG C
31,106		100.00% Impervious Area

Tc (min)	Length (feet)	Slope (ft/ft)	Velocity (ft/sec)	Capacity (cfs)	Description
6.0					Direct Entry, Direct Entry

Summary for Pond 4P: Pond 4

Inflow Area = 0.714 ac, 100.00% Impervious, Inflow Depth = 4.16" for 100-yr event
 Inflow = 0.75 cfs @ 7.87 hrs, Volume= 0.248 af
 Outflow = 0.75 cfs @ 7.88 hrs, Volume= 0.248 af, Atten= 0%, Lag= 0.8 min
 Primary = 0.75 cfs @ 7.88 hrs, Volume= 0.248 af

Routing by Stor-Ind method, Time Span= 0.00-50.00 hrs, dt= 0.05 hrs
 Peak Elev= 142.81' @ 7.88 hrs Surf.Area= 545 sf Storage= 1,257 cf

Plug-Flow detention time= 179.3 min calculated for 0.248 af (100% of inflow)
 Center-of-Mass det. time= 180.0 min (837.6 - 657.6)

Volume	Invert	Avail.Storage	Storage Description
#1	140.50'	2,126 cf	Custom Stage Data (Prismatic) Listed below (Recalc)

Elevation (feet)	Surf.Area (sq-ft)	Inc.Store (cubic-feet)	Cum.Store (cubic-feet)
140.50	545	0	0
144.40	545	2,126	2,126

Device	Routing	Invert	Outlet Devices
#1	Device 2	140.50'	2.000 in/hr Exfiltration over Surface area
#2	Primary	137.75'	8.0" Vert. 8" Outlet C= 0.600
#3	Primary	142.70'	24.0" Horiz. Beehive Overflow C= 0.600 Limited to weir flow at low heads

Primary OutFlow Max=0.75 cfs @ 7.88 hrs HW=142.81' (Free Discharge)
 2=8" Outlet (Passes 0.03 cfs of 3.65 cfs potential flow)
 1=Exfiltration (Exfiltration Controls 0.03 cfs)
 3=Beehive Overflow (Weir Controls 0.72 cfs @ 1.07 fps)

Summary for Subcatchment 5S: Basin 5

Runoff = 0.31 cfs @ 7.89 hrs, Volume= 0.100 af, Depth= 1.16"

Runoff by SCS TR-20 method, UH=SCS, Weighted-CN, Time Span= 0.00-50.00 hrs, dt= 0.05 hrs
Type IA 24-hr WQ Rainfall=1.38"

Area (sf)	CN	Description
44,865	98	Paved parking, HSG C
44,865		100.00% Impervious Area

Tc (min)	Length (feet)	Slope (ft/ft)	Velocity (ft/sec)	Capacity (cfs)	Description
6.0					Direct Entry, Direct Entry

Summary for Pond 5P: Pond 5

Inflow Area = 1.030 ac, 100.00% Impervious, Inflow Depth = 1.16" for WQ event
 Inflow = 0.31 cfs @ 7.89 hrs, Volume= 0.100 af
 Outflow = 0.05 cfs @ 11.58 hrs, Volume= 0.100 af, Atten= 82%, Lag= 221.3 min
 Primary = 0.05 cfs @ 11.58 hrs, Volume= 0.100 af

Routing by Stor-Ind method, Time Span= 0.00-50.00 hrs, dt= 0.05 hrs
 Peak Elev= 142.14' @ 11.58 hrs Surf.Area= 1,187 sf Storage= 1,434 cf

Plug-Flow detention time= 345.6 min calculated for 0.100 af (100% of inflow)
 Center-of-Mass det. time= 345.8 min (1,042.2 - 696.3)

Volume	Invert	Avail.Storage	Storage Description
#1	140.00'	2,627 cf	Custom Stage Data (Prismatic) Listed below (Recalc)

Elevation (feet)	Surf.Area (sq-ft)	Inc.Store (cubic-feet)	Cum.Store (cubic-feet)
140.00	151	0	0
143.00	1,600	2,627	2,627

Device	Routing	Invert	Outlet Devices
#1	Device 2	140.00'	2.000 in/hr Exfiltration over Surface area
#2	Primary	136.25'	8.0" Vert. 8" Outlet C= 0.600
#3	Primary	142.20'	24.0" Horiz. Beehive Overflow C= 0.600 Limited to weir flow at low heads

Primary OutFlow Max=0.05 cfs @ 11.58 hrs HW=142.14' (Free Discharge)
 2=8" Outlet (Passes 0.05 cfs of 3.96 cfs potential flow)
 1=Exfiltration (Exfiltration Controls 0.05 cfs)
 3=Beehive Overflow (Controls 0.00 cfs)

Summary for Subcatchment 5S: Basin 5

Runoff = 1.08 cfs @ 7.87 hrs, Volume= 0.357 af, Depth= 4.16"

Runoff by SCS TR-20 method, UH=SCS, Weighted-CN, Time Span= 0.00-50.00 hrs, dt= 0.05 hrs
Type IA 24-hr 100-yr Rainfall=4.40"

Area (sf)	CN	Description
44,865	98	Paved parking, HSG C
44,865		100.00% Impervious Area

Tc (min)	Length (feet)	Slope (ft/ft)	Velocity (ft/sec)	Capacity (cfs)	Description
6.0					Direct Entry, Direct Entry

Summary for Pond 5P: Pond 5

Inflow Area = 1.030 ac, 100.00% Impervious, Inflow Depth = 4.16" for 100-yr event
 Inflow = 1.08 cfs @ 7.87 hrs, Volume= 0.357 af
 Outflow = 1.08 cfs @ 7.90 hrs, Volume= 0.357 af, Atten= 0%, Lag= 2.0 min
 Primary = 1.08 cfs @ 7.90 hrs, Volume= 0.357 af

Routing by Stor-Ind method, Time Span= 0.00-50.00 hrs, dt= 0.05 hrs
 Peak Elev= 142.34' @ 7.90 hrs Surf.Area= 1,279 sf Storage= 1,669 cf

Plug-Flow detention time= 150.5 min calculated for 0.357 af (100% of inflow)
 Center-of-Mass det. time= 150.4 min (808.0 - 657.6)

Volume	Invert	Avail.Storage	Storage Description
#1	140.00'	2,627 cf	Custom Stage Data (Prismatic) Listed below (Recalc)

Elevation (feet)	Surf.Area (sq-ft)	Inc.Store (cubic-feet)	Cum.Store (cubic-feet)
140.00	151	0	0
143.00	1,600	2,627	2,627

Device	Routing	Invert	Outlet Devices
#1	Device 2	140.00'	2.000 in/hr Exfiltration over Surface area
#2	Primary	136.25'	8.0" Vert. 8" Outlet C= 0.600
#3	Primary	142.20'	24.0" Horiz. Beehive Overflow C= 0.600 Limited to weir flow at low heads

Primary OutFlow Max=1.08 cfs @ 7.90 hrs HW=142.33' (Free Discharge)
 2=8" Outlet (Passes 0.06 cfs of 4.03 cfs potential flow)
 1=Exfiltration (Exfiltration Controls 0.06 cfs)
 3=Beehive Overflow (Weir Controls 1.02 cfs @ 1.20 fps)

Pond 1P: Planter 1

Hydrograph

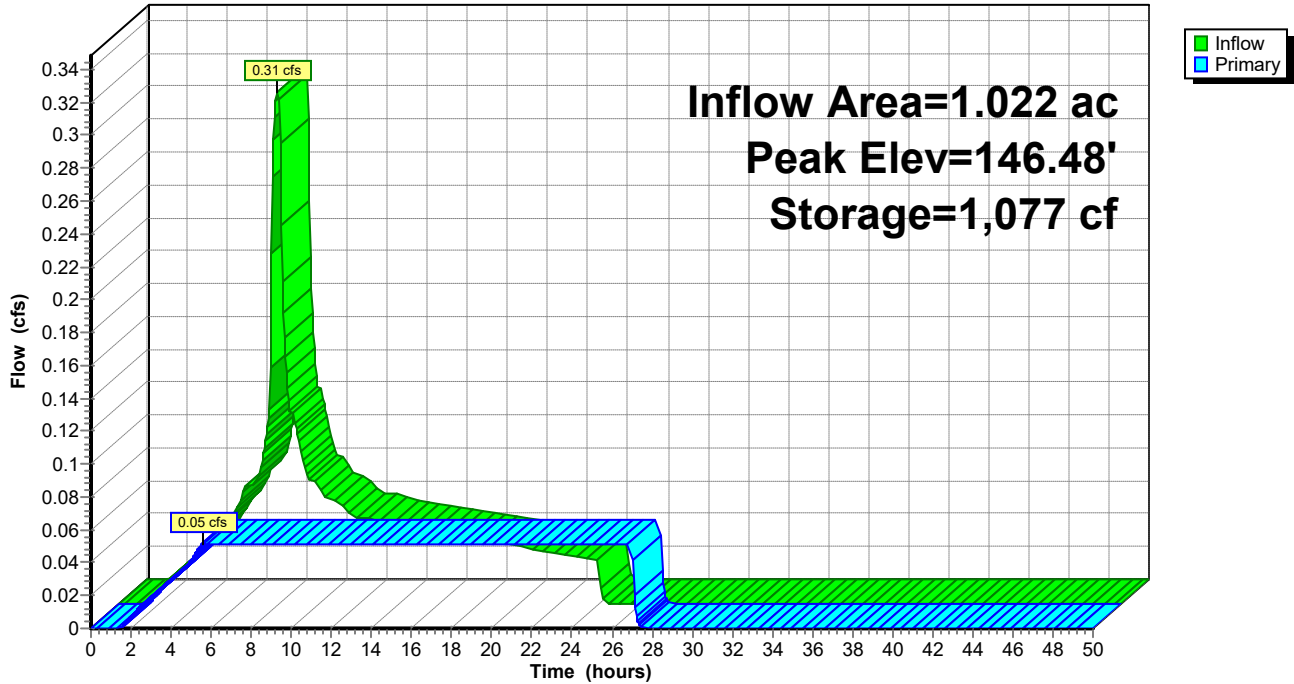

Pond 2P: Planter 2

Hydrograph

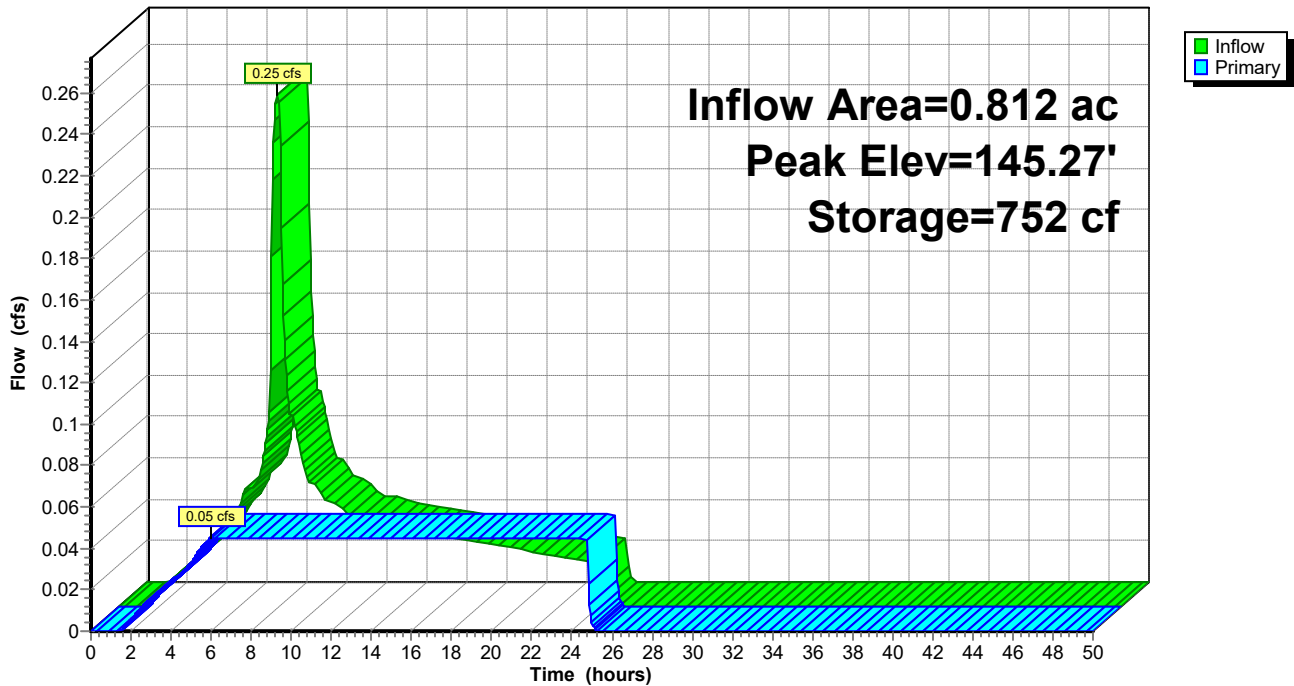

Pond 3P: Planter 3

Hydrograph

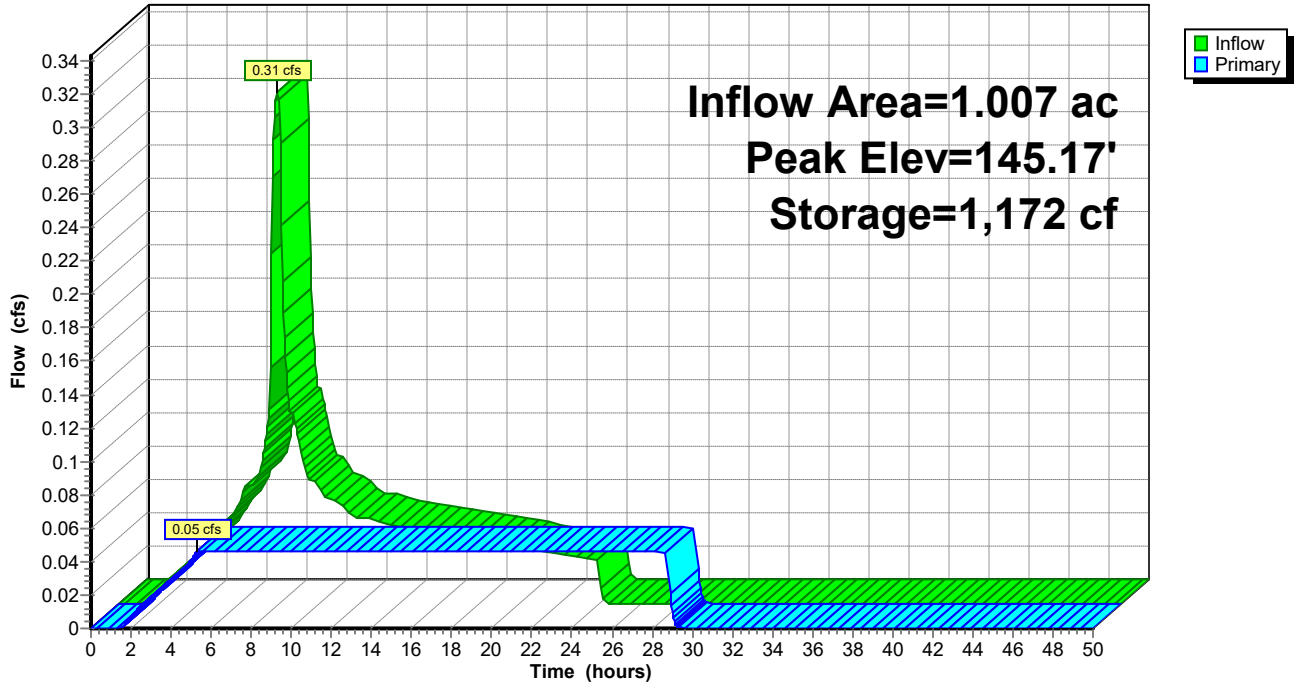

Pond 4P: Pond 4

Hydrograph

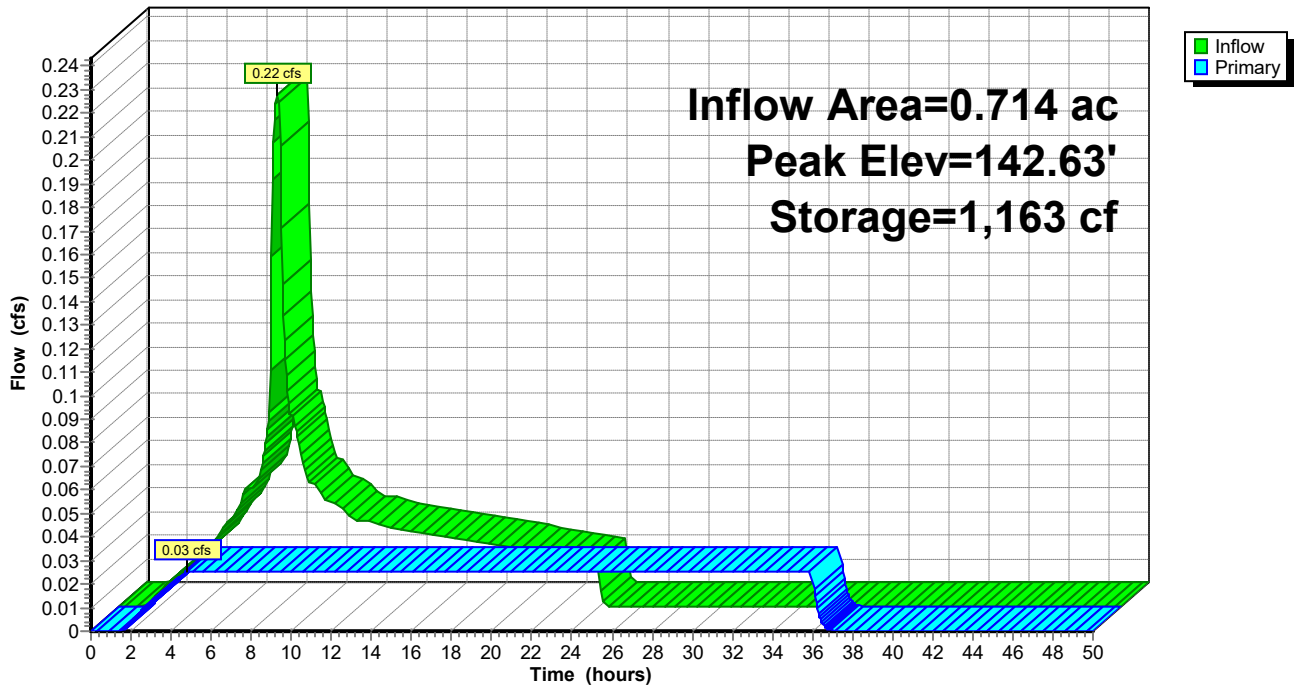

Pond 5P: Pond 5

Hydrograph

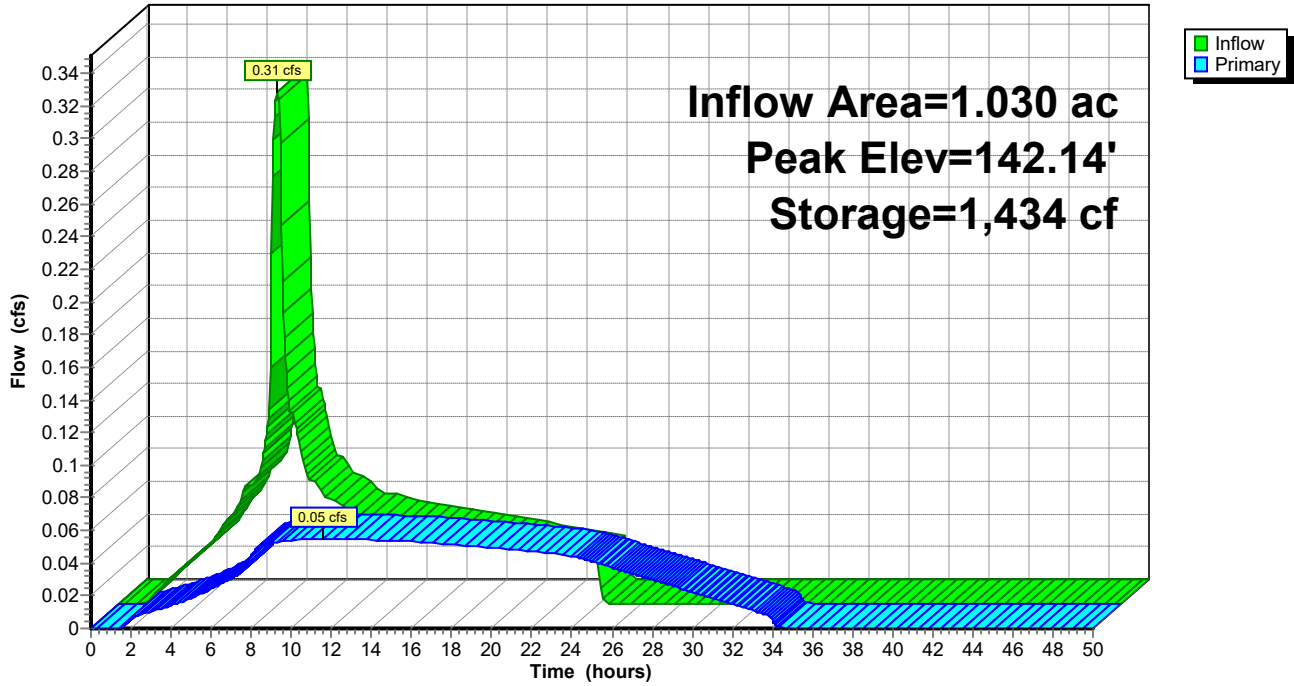

Pond 1P: Planter 1

Hydrograph

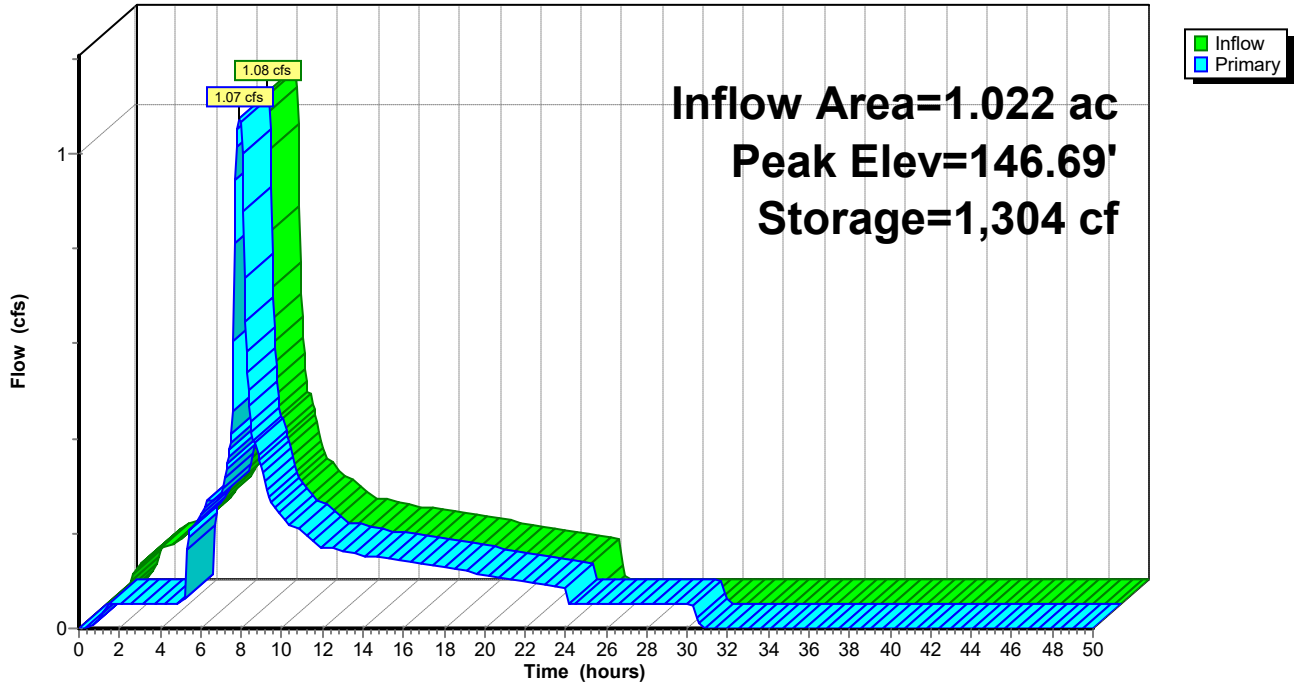

Pond 2P: Planter 2

Hydrograph

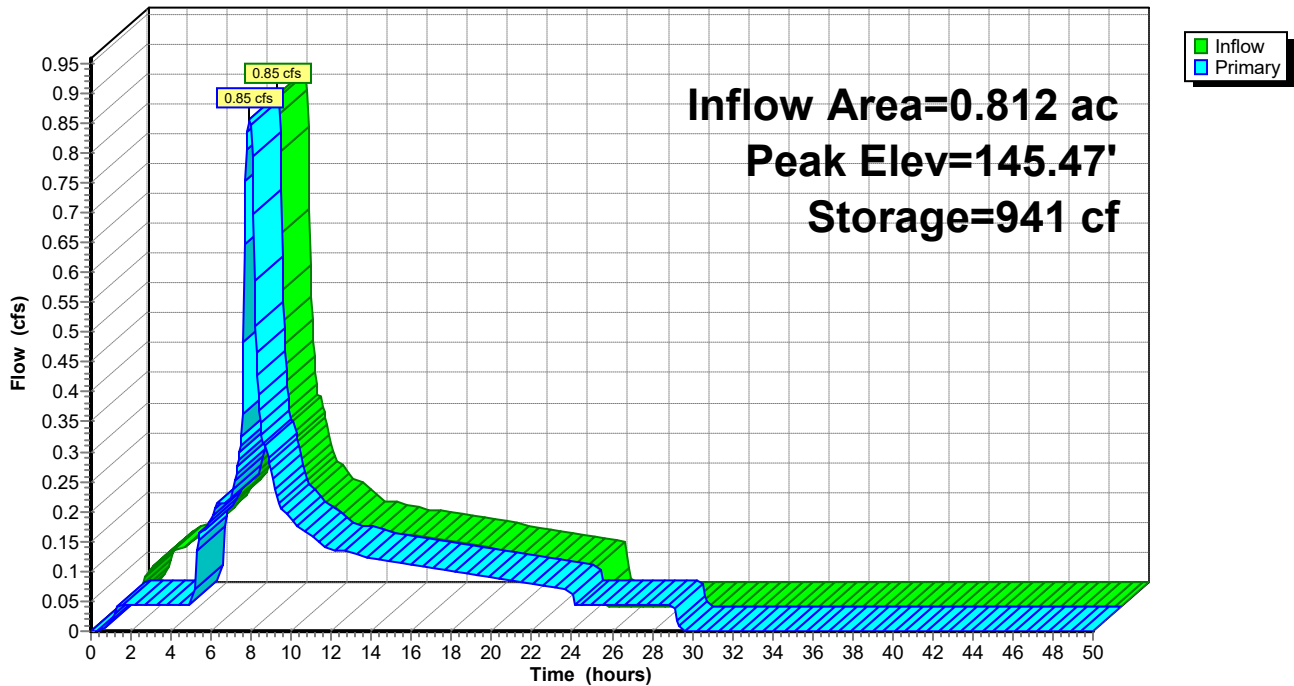

Pond 3P: Planter 3

Hydrograph

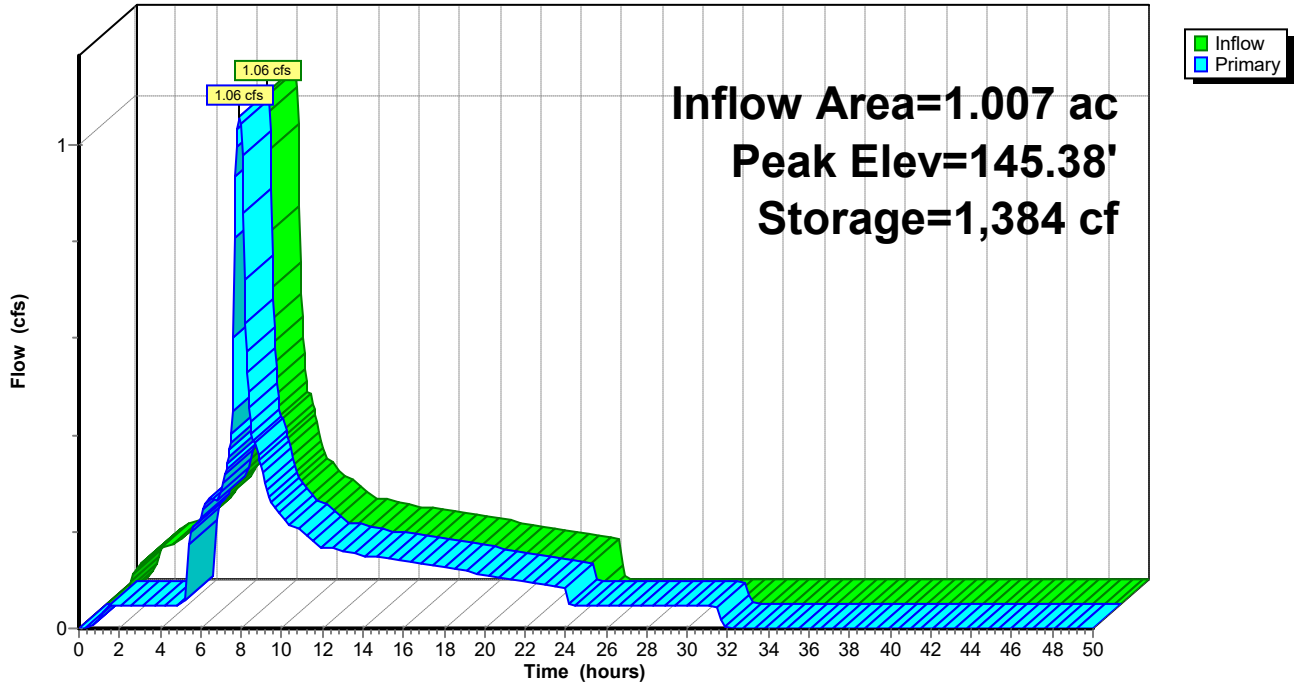

Pond 4P: Pond 4

Hydrograph

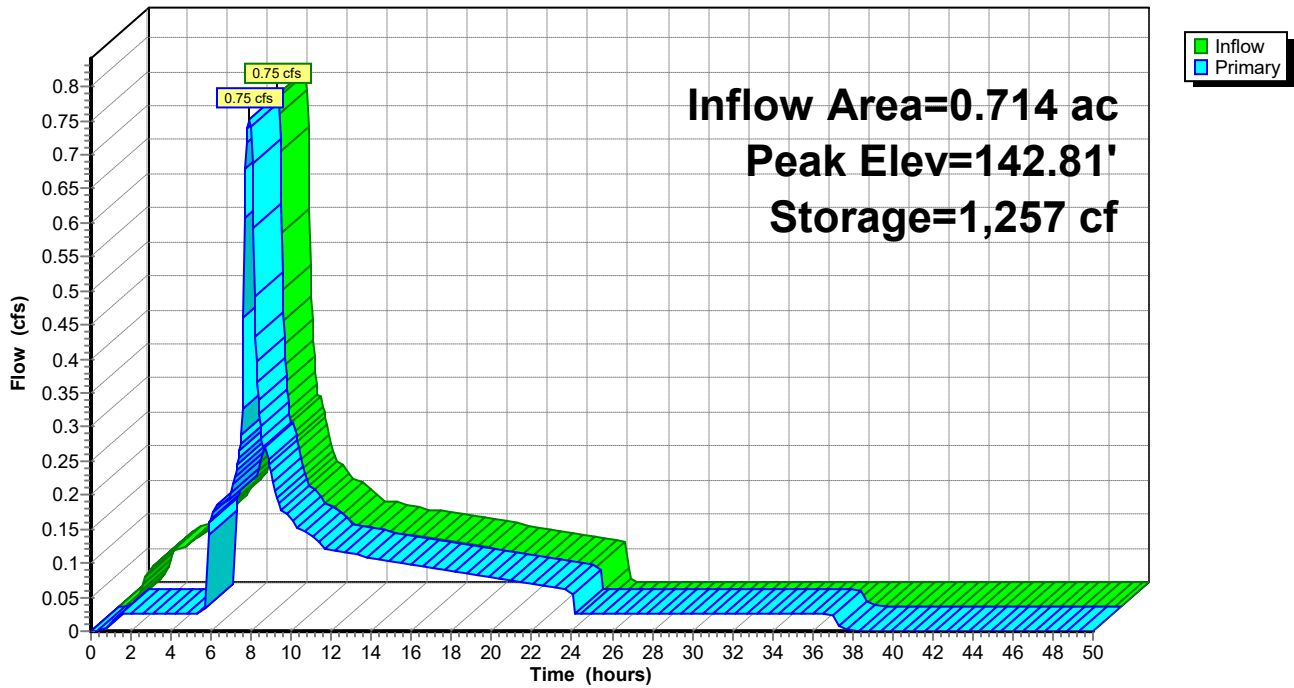

Pond 5P: Pond 5

Hydrograph

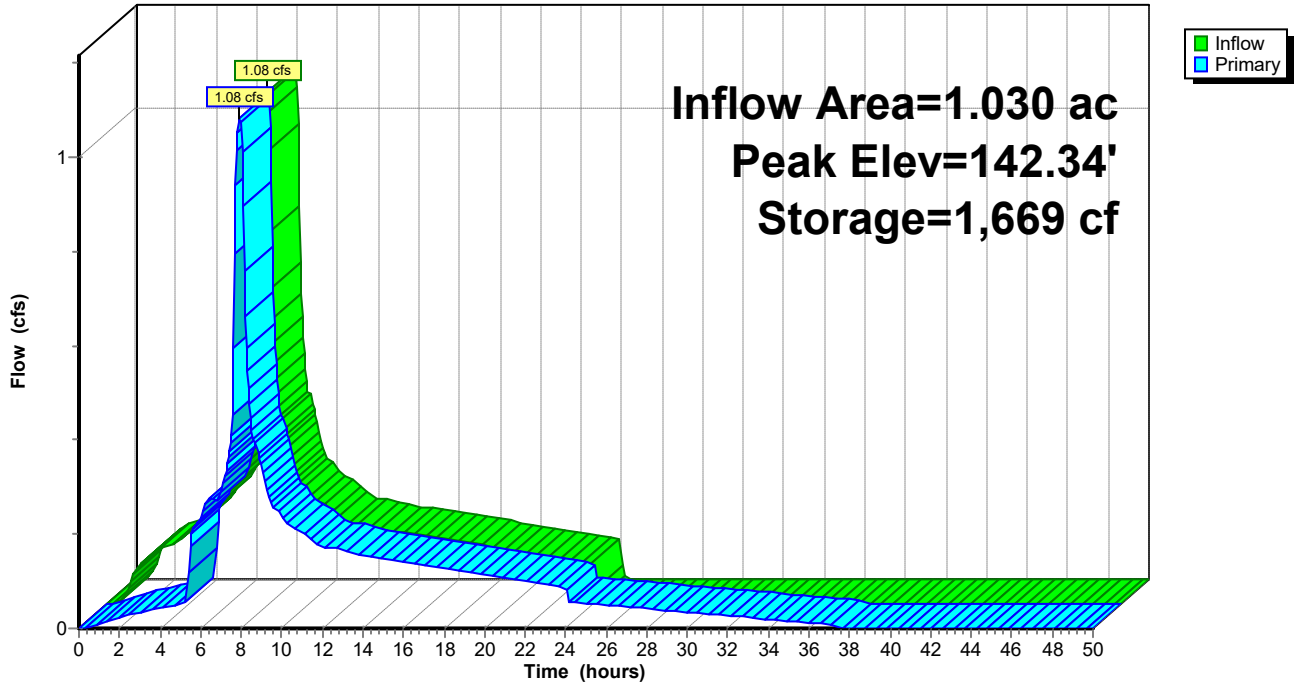

Appendix D: Operations & Maintenance Form

Chapter 109

Division 011 - Operations and Maintenance of Stormwater Facilities

Appendix A to 109-011 – Private Stormwater Facilities Agreement

This Agreement is made and entered into this _____ day of _____, 20____, by and between the City of Salem (City) and _____ (Owner) whose address is _____.

RECITALS

A. Owner has developed or will develop property with the stormwater facilities listed below. (List the type of private stormwater facilities on site and the quantity of each type).

Facility type (list each)	Quantity
_____	_____
_____	_____
_____	_____
_____	_____
_____	_____
_____	_____
_____	_____
_____	_____
_____	_____
_____	_____

B. The Facilities enable development of property while mitigating the adverse impacts of stormwater runoff and pollutants associated with stormwater runoff prior to discharge from the property directly or indirectly to the public stormwater system, another private stormwater system, or to receiving waters.

C. The property benefited by the stormwater facilities and subject to the obligation of this Agreement is described below or in Exhibit A (Property) attached hereto and incorporated by reference, with the location of each stormwater facility as indicated.

D. The stormwater facilities are designed by a registered professional engineer in accordance with the requirements of Salem Revised Code Chapter 71 (Stormwater) and the *Public Works Design Standards*.

E. Failure to properly inspect and maintain the stormwater facilities can result in unacceptable impacts to the public stormwater system, receiving waters, the environment, and downstream properties.

Chapter 109

Division 011 - Operations and Maintenance of Stormwater Facilities

Appendix A to 109-011 – Private Stormwater Facilities Agreement

NOW, THEREFORE, it is agreed by and between the parties as follows:

1. MAINTENANCE

Owner agrees to maintain each stormwater facility in accordance with requirements provided by, or approved by, the City so that it is in proper working condition for effective pollutant removal, infiltration, and/or flow control.

2. INSPECTION

Owner agrees to inspect each stormwater facility in accordance with requirements provided by, or approved by, the City.

3. RECORDKEEPING

Owner agrees to maintain a record of the construction of, and all inspections, maintenance, and repair activities to, each stormwater facility and to make plans, records, procedures, and schedules of maintenance available to the Public Works Director during inspection of each stormwater facility, and at other reasonable times upon request of the Public Works Director.

4. REPAIR

Owner agrees to make any repairs as necessary to keep each stormwater facility in continuous working order. All deficiencies shall be corrected at Owner's expense within 30 days after the deficiency has been identified a deficiency, unless more than 30 days is reasonably needed to correct a deficiency. Owner shall have a reasonable period to correct the deficiency so long as the correction is commenced within the 30-day period and is diligently prosecuted to completion.

5. CITY CORRECTIONS

If correction of all Owner- or City-identified deficiencies is not completed within 30 days after Owner's inspection or City notice, City shall have the right to have any deficiencies corrected. In such instances, City:

- (i) Shall have access to the stormwater facilities for the purpose of correcting such deficiencies; and
- (ii) Shall bill Owner for all costs reasonably incurred by City for work performed to correct the deficiencies following Owner's failure to correct any deficiencies in the Facilities.

Owner shall pay the City within 30 days of the date of the invoice. Owner understands and agrees that upon non-payment, City may place a lien on the property for the amount plus interest and penalties.

6. ACCESS

Owner grants City the right to inspect the stormwater facilities. City will endeavor to give at least 10 days prior notice to Owner, except that no notice shall be required in case of an emergency. City shall determine whether deficiencies need to be corrected. Owner will be notified in writing of the deficiencies.

Chapter 109

Division 011 - Operations and Maintenance of Stormwater Facilities

Appendix A to 109-011 – Private Stormwater Facilities Agreement

7. CHANGE OF OWNERSHIP

If a change of ownership occurs, owner agrees to transfer all records of installation, repair, and maintenance of each stormwater facility to the new property owner. Owner will inform future purchasers and other successors and assignees of the existence of the stormwater facility and of the requirements for continued inspection and maintenance of the stormwater facility.

8. EMERGENCY MEASURES

If, at any time, City reasonably determines that a stormwater facility is creating an imminent threat to public health, safety, or welfare, City may immediately and without prior notice to Owner take measures reasonably designed to remedy the threat. City shall provide notice of the threat and the measures taken to Owner as soon as reasonably practicable. City may charge Owner for the cost of these corrective measures.

9. HOLD HARMLESS

Owner shall indemnify and hold City harmless from any and all claims for damages to persons or property arising from the construction, operation, inspection, maintenance, or use of each stormwater facility.

10. FORCE AND EFFECT

This Agreement has the same force and effect as any deed covenant running with the land and shall benefit and bind all owners of the property present and future, and their heirs, successors and assigns.

11. AMENDMENTS

The terms of this Agreement may be amended only by mutual agreement of the parties. Any amendments shall be in writing, shall refer specifically to this Agreement, and shall be valid only when executed by the owners of the property and the City and recorded in the Official Records of the county where the Property is located.

12. PREVAILING PARTY

In any action brought by either party to enforce the terms of this Agreement, the prevailing party shall be entitled to recover all costs, including reasonable attorney's fees as may be determined by the court having jurisdiction, including any appeal.

13. SEVERABILITY

The invalidity of any section, clause, sentence, or provision of this Agreement shall not affect the validity of any other part of this Agreement, which can be given effect without such invalid part or parts.

After recording, return to:
City of Salem Public Works Department
555 Liberty Street SE, Room 325
Salem OR 97301-3513

Chapter 109

Division 011 - Operations and Maintenance of Stormwater Facilities

Appendix A to 109-011 – Private Stormwater Facilities Agreement

IN WITNESS WHEREOF, the parties hereto have signed this Agreement as of the date below.

By: _____
Owner

Title

STATE OF OREGON)
) ss.
County of _____)

This instrument was acknowledged before me on _____, 20____, by
_____.

Notary Public—State of Oregon
My commission expires: _____

Approved:

By: _____
Public Works Director

City of Salem, Oregon

By: _____
City Manager

STATE OF OREGON)
) ss.
County of _____)

This instrument was acknowledged before me on _____, 20____, by
_____, as City Manager of the City of Salem, Oregon.

Notary Public—State of Oregon
My commission expires: _____

Chapter 109
Division 011 - Operations and Maintenance of Stormwater Facilities

Appendix B to 109-011 – Facility Maintenance Forms

This appendix contains Facility Maintenance Forms that provide minimum requirements for inspection, maintenance, and repair activities for the following types of stormwater facilities:

1. Stormwater Planters
2. Rain Gardens
3. Vegetated Filter Strips
4. Swales (Vegetated, Grassy, and Street)
5. Detention Basins
6. Subsurface Gravel Treatment Wetland
7. Constructed Treatment Wetlands
8. Manufactured Treatment Technology
9. Green Roofs
10. Sand Filters
11. Pervious Pavement
12. Underground Detention Tanks, Vaults, and Pipes
13. Conveyance: Piped
14. Conveyance: Open Channel
15. Soakage Trenches
16. Drywells

Chapter 109
Division 011 - Operations and Maintenance of Stormwater Facilities

Appendix B to 109-011 – Facility Maintenance Forms

1. Stormwater Planter

Stormwater Planters are designed to allow runoff to filter through layers of topsoil (thus capturing pollutants) and then either infiltrate into the native soils (infiltration planter) or be collected in a pipe to be discharged off-site (filtration planter). The planter is sized to accept runoff and temporarily store the water in a reservoir on top of the soil. The filtration planter is designed with an impervious bottom or is placed on an impervious surface. Water should drain through the planter within 24 hours after a storm event.

Inspections

All facility components and vegetation shall be inspected for proper operations and structural stability. *These inspections shall occur, at a minimum, quarterly for the first two years from the date of installation, and two times per year thereafter.* It is recommended that a visual inspection be made within 48 hours after each major storm event to ensure proper function. The facility owner must keep a log, recording all inspection dates, observations, and maintenance activities. The following items shall be inspected and maintained as stated:

Date: ___/___/_____ Inspector's Name: _____

Downspout from rooftop or sheet flow from paving allows unimpeded stormwater flow to the planter.

- Debris shall be removed routinely and upon discovery.
- Damaged pipe shall be repaired upon discovery.

Inspection Comments: _____

Splash blocks prevent splashing against adjacent structures and convey water without disrupting media.

- Any deficiencies in structure such as cracking, rotting, and failure shall be repaired.

Inspection Comments: _____

Planter reservoir receives and detains stormwater prior to infiltration. Water should drain from planter within 24 hours of storm event.

- Sources of clogging shall be identified and corrected.
- Topsoil may need to be amended with sand or compost, or replaced.

Inspection Comments: _____

Amended soils consisting of sand, compost, drain rock, and topsoil shall allow stormwater to percolate uniformly through the planter.

- The planter shall be excavated and cleaned, and gravel or soil shall be replaced to correct low infiltration rates.
- Holes that are not consistent with the design and allow water to flow directly through the planter to the ground shall be plugged.
- Sediment accumulation shall be hand-removed with minimum damage to vegetation using proper erosion control measures. Sediment shall be removed if it is more than 4 inches thick or so thick as to damage or kill vegetation.
- Litter and debris shall be removed.

Inspection Comments: _____

Chapter 109
Division 011 - Operations and Maintenance of Stormwater Facilities

Appendix B to 109-011 – Facility Maintenance Forms

1. Stormwater Planter (continued)

Planter shall contain filter media and vegetation.

- Structural deficiencies in the planter including rot, cracks, and failure shall be repaired.

Inspection Comments: _____

Overflow pipe safely conveys flow exceeding reservoir capacity to an approved stormwater receiving system.

- Overflow pipe shall be kept clear at all times.
- Damaged pipe shall be repaired or replaced upon discovery.

Inspection Comments: _____

Vegetation shall be healthy and dense enough to provide filtering while protecting underlying soils from erosion. Proper horticultural practices shall be employed to ensure plants are vigorous and healthy.

- Mulch shall be replenished as needed, but not inhibiting water flow.
- Vegetation, large shrubs, or trees that limit access or interfere with planter operation shall be pruned or removed.
- Fallen leaves and debris from deciduous plant foliage shall be raked and removed.
- Nuisance or prohibited vegetation from the City of Salem Non-Native Invasive Plant list shall be removed when discovered. Invasive vegetation shall be removed upon discovery.
- Dead vegetation shall be removed upon discovery.
- Vegetation shall be replaced as soon as possible to maintain cover density and control erosion where soils are exposed.

Inspection Comments: _____

Debris and litter shall be removed to ensure stormwater infiltration and to prevent clogging of overflow drains and interference with plant growth.

Inspection Comments: _____

Spill prevention measures shall be exercised when handling substances that contaminate stormwater.

- Releases of pollutants shall be corrected and reported to the City as soon as identified.

Inspection Comments: _____

Training and/or written guidance information for O&M of stormwater planters shall be provided to all property owners and tenants. This Facility Maintenance Form can be used to meet this requirement.

Inspection Comments: _____

Access to the stormwater planter shall be safe and efficient. Egress and ingress routes shall be maintained to design standards. Roadways shall be maintained to accommodate size and weight of vehicles, if applicable.

- Obstacles preventing maintenance personnel and/or equipment access to the stormwater planter shall be removed.
- Gravel or ground cover shall be added if erosion has occurred.

Inspection Comments: _____

Chapter 109
Division 011 - Operations and Maintenance of Stormwater Facilities

Appendix B to 109-011 – Facility Maintenance Forms

1. Stormwater Planter (continued)

Nuisance insects and rodents shall not be harbored in the stormwater planter.

Pest control measures shall be taken when nuisance insects/rodents are found to be present.

- Holes in the ground located in and around the stormwater planter shall be filled and compacted.

Inspection Comments: _____

Chapter 109
Division 011 - Operations and Maintenance of Stormwater Facilities

Appendix B to 109-011 – Facility Maintenance Forms

2. Rain Garden

A rain garden is a **vegetated infiltration basin** or depression created by excavation, berms, or small dams to provide for short-term ponding of surface water until it percolates into the soil. The basin should infiltrate stormwater within 24 hours.

Inspections

All facility components and vegetation shall be inspected for proper operations and structural stability. *These inspections shall occur, at a minimum, quarterly for the first two years from the date of installation, and two times per year thereafter.* It is recommended that a visual inspection be made within 48 hours after each major storm event to ensure proper function. The facility owner must keep a log, recording all inspection dates, observations, and maintenance activities. The following items shall be inspected and maintained as stated:

Date: ____/____/____

Inspector's Name: _____

Basin inlet shall ensure unrestricted stormwater flow to the vegetated basin.

- Sources of erosion shall be identified and controlled when native soil is exposed or erosion channels are present.
- Inlet shall be kept clear at all times.
- Rock splash pads shall be replenished to prevent erosion.

Inspection Comments: _____

Embankment, dikes, berms, and side slopes retain water in the infiltration basin.

- Structural deficiencies shall be corrected upon discovery.
- Slopes shall be stabilized using appropriate erosion control measures when soil is exposed/flow channels are forming.
- Sources of erosion damage shall be identified and controlled.

Inspection Comments: _____

Overflow or emergency spillway conveys flow exceeding reservoir capacity to an approved stormwater receiving system.

- Overflow shall be kept clear at all times.
- Sources of erosion damage shall be identified and controlled when soil is exposed.
- Rocks or other armament shall be replaced when only one layer of rock exists.

Inspection Comments: _____

Amended soils shall allow stormwater to percolate uniformly through the infiltration basin. If water remains 36 hours after a storm, sources of possible clogging shall be identified and corrected.

- Basin shall be raked and, if necessary, soil shall be excavated and cleaned or replaced.

Inspection Comments: _____

Chapter 109
Division 011 - Operations and Maintenance of Stormwater Facilities

Appendix B to 109-011 – Facility Maintenance Forms

2. Rain Garden (continued)

Sediment/Basin debris management shall prevent loss of infiltration basin volume caused by sedimentation.

- Sediment exceeding 3 inches in depth, or so thick as to damage or kill vegetation, shall be removed.
- Sediment accumulation shall be hand-removed with minimum damage to vegetation using proper erosion control measures.

Inspection Comments: _____

Debris and litter shall be removed to ensure stormwater infiltration and to prevent clogging of overflow drains and interference with plant growth.

- Restricted sources of sediment and debris, such as discarded lawn clippings, shall be identified and prevented.

Inspection Comments: _____

Vegetation shall be healthy and dense enough to provide filtering while protecting underlying soils from erosion. Proper horticultural practices shall be employed to ensure that plants are vigorous and healthy.

- Mulch shall be replenished as needed, but not inhibiting water flow.
- Vegetation, large shrubs, or trees that interfere with rain garden operation shall be pruned.
- Fallen leaves and debris from deciduous plant foliage shall be raked and removed.
- Nuisance or prohibited vegetation from the City of Salem Non-Native Invasive Plant list shall be removed when discovered. Invasive vegetation shall be removed immediately upon discovery.
- Dead vegetation shall be removed upon discovery.
- Vegetation shall be replaced as soon as possible to maintain cover density and control erosion where soils are exposed.

Inspection Comments: _____

Spill prevention measures shall be exercised when handling substances that contaminate stormwater.

- Releases of pollutants shall be corrected as soon as identified.

Inspection Comments: _____

Training and/or written guidance information for operating and maintaining vegetated infiltration basins shall be provided to all property owners and tenants. This Facility Maintenance Form can be used to meet this requirement.

Inspection Comments: _____

Access to the infiltration basin shall be safe and efficient. Egress and ingress routes shall be maintained to design standards. Roadways shall be maintained to accommodate size and weight of vehicles, if applicable.

- Obstacles preventing maintenance personnel and/or equipment access to the infiltration basin shall be removed.
- Gravel or ground cover shall be added if erosion has occurred.

Inspection Comments: _____

Chapter 109
Division 011 - Operations and Maintenance of Stormwater Facilities

Appendix B to 109-011 – Facility Maintenance Forms

2. Rain Garden (continued)

Nuisance insects and rodents shall not be harbored in the infiltration basin. Pest control measures shall be taken when nuisance insects/rodents are found to be present.

- Holes in the ground located in and around the infiltration basin shall be filled.

Inspection Comments: _____

If used at this site, the following will be applicable:

Fences shall be maintained to preserve their functionality and appearance.

- Collapsed fences shall be restored to an upright position.
- Jagged edges and damaged fences shall be repaired or replaced.

Inspection Comments: _____

Appendix E: Reduced-Size Grading & Drainage Plan

ABBREVIATIONS:

- EXISTING:**
(RIM): EXISTING RIM ELEVATION
- PROPOSED:**
FFE: FINISHED FLOOR ELEVATION
FG: FINISHED GRADE ELEVATION
RIM: RIM ELEVATION
AC: ASPHALT CONCRETE ELEVATION
TC: TOP OF CURB ELEVATION
BSE: BOTTOM OF STAIR ELEVATION
TSE: TOP OF STAIR ELEVATION
TW: TOP OF WALL ELEVATION
BW: BOTTOM OF WALL ELEVATION
SW: SIDEWALK ELEVATION
TD: TRENCH DRAIN RIM ELEVATION
GUT: GUTTER ELEVATION
- DOWNWARD SLOPE: X.X%

GENERAL NOTES:

- (P) PRIOR TO CONSTRUCTION AND ORDERING PIPE MATERIALS, CONTRACTOR SHALL POTHOLE EXISTING UTILITIES TO VERIFY EXACT LOCATION, ALIGNMENT, DEPTH, AND SIZE. CONTACT ENGINEER IF ADJUSTMENT IS REQUIRED.

STORM DRAIN (SD) KEYED NOTES: #

- CONNECT TO EXISTING 34" CONCRETE PUBLIC STORM MAIN WITH NEW 48" MANHOLE. RIM AND INVERT ELEVATION (IE) PER PLANS.
- 48" SD MANHOLE. RIM AND IE PER PLAN.
- 24" SD MINI MANHOLE. RIM AND IE PER PLAN.
- SD BEEHIVE OVERFLOW.
- SD CLEANOUT (CO). IE PER PLAN.
- SD AREA DRAIN. RIM AND IE PER PLAN.
- ADJUST EXISTING MANHOLE RIM TO FINISHED GRADE ELEVATION.

LEGEND

EXISTING GROUND CONTOUR (1 FT)	---	149
EXISTING GROUND CONTOUR (5 FT)	---	150
FINISHED GRADE CONTOUR (1 FT)	---	149
FINISHED GRADE CONTOUR (5 FT)	---	150
PROPOSED MANHOLE (MH)	●	
PROPOSED CLEANOUT (CO)/DOWNSPOUT (DS)	•	
PROPOSED CATCH BASIN (CB)	■	
BEEHIVE OVERFLOW DRAIN (BH)	○	
MINI MANHOLE (MMH)	○	
STORMWATER FACILITY	+	
ADA RAMP LANDING AREA (2% MAX ANY DIRECTION)	▨	
TRENCH DRAIN	---	

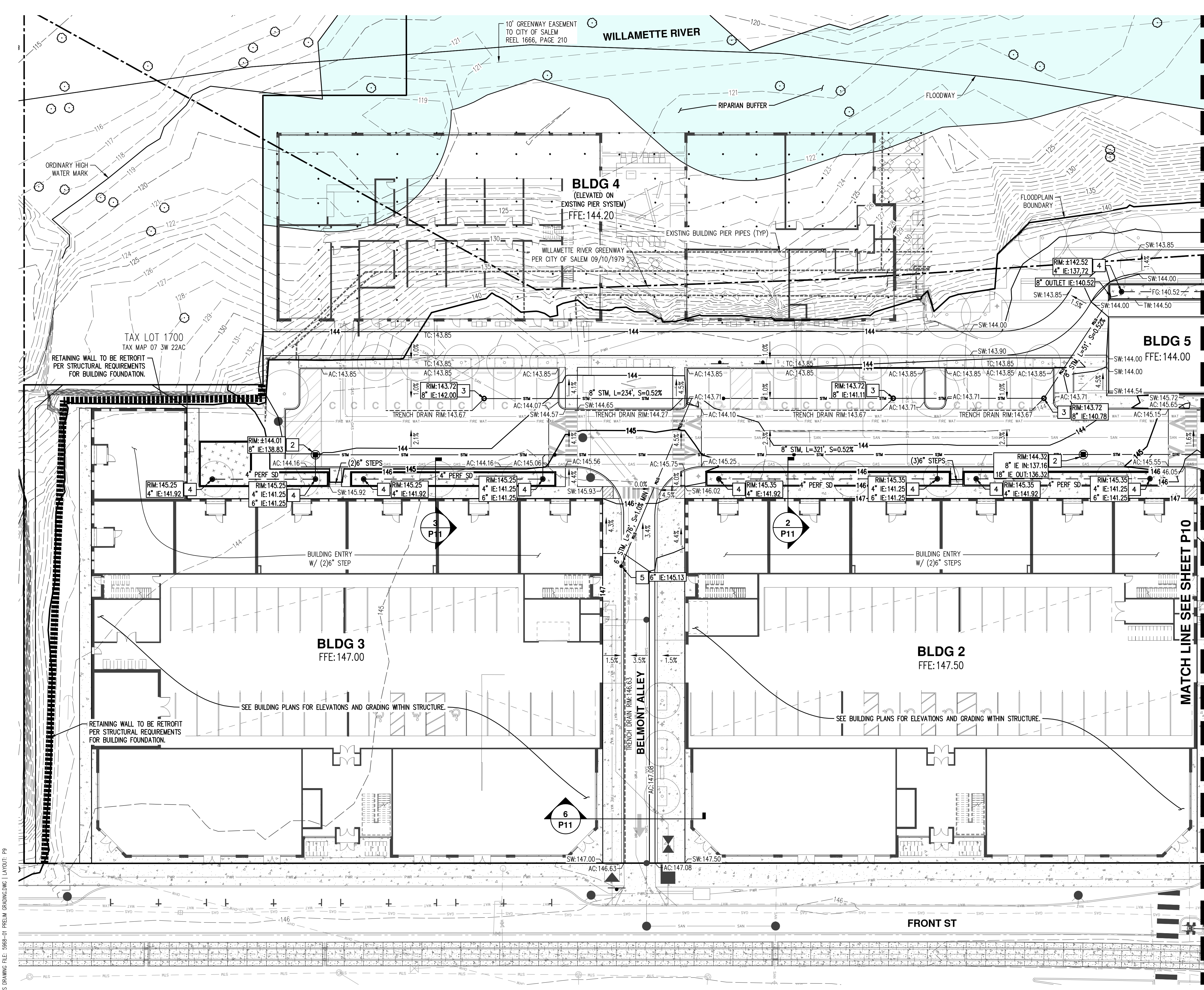

PRELIMINARY ONSITE GRADING AND DRAINAGE PLAN
THE CANNERY
FUND
SALEM, OREGON



RENEWED: DECEMBER 31, 2024
 JOB NUMBER: 5988-01
 DATE: 01/23/2024
 DESIGNED BY: TDR
 DRAWN BY: MJM
 CHECKED BY: TDR

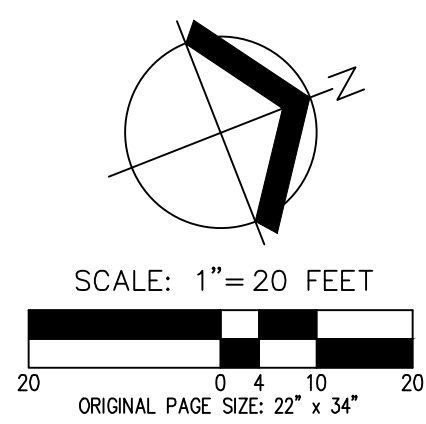

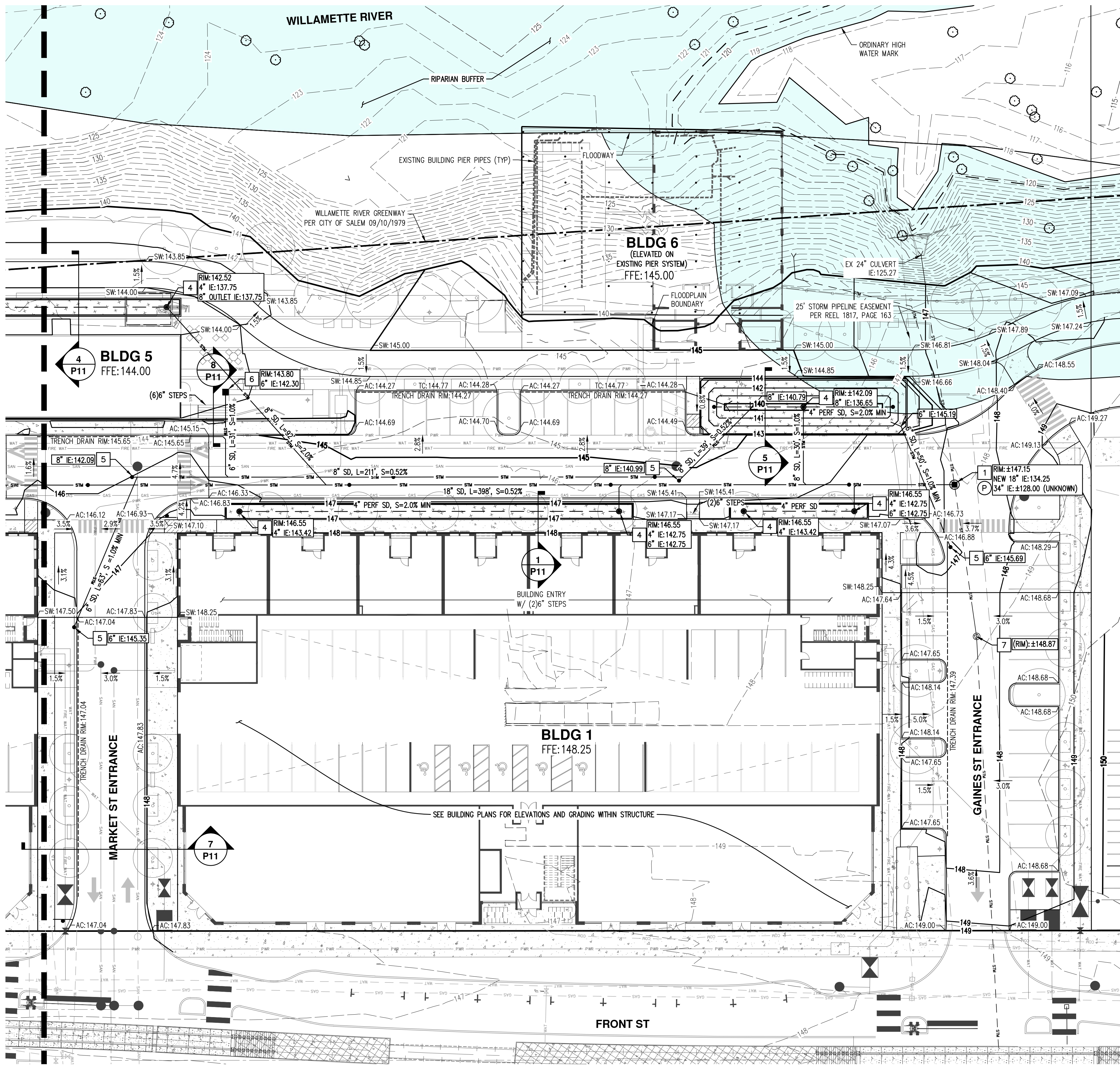

ABBREVIATIONS:

EXISTING:
 (RM): EXISTING RIM ELEVATION

PROPOSED:
 FFE: FINISHED FLOOR ELEVATION
 FG: FINISHED GRADE ELEVATION
 RM: RIM ELEVATION
 AC: ASPHALT CONCRETE ELEVATION
 TC: TOP OF CURB ELEVATION
 BSE: BOTTOM OF STAIR ELEVATION
 TSE: TOP OF STAIR ELEVATION
 TW: TOP OF WALL ELEVATION
 BW: BOTTOM OF WALL ELEVATION
 SW: SIDEWALK ELEVATION
 TD: TRENCH DRAIN RIM ELEVATION
 GUT: GUTTER ELEVATION

DOWNWARD SLOPE: X.X%

GENERAL NOTES:

(P) PRIOR TO CONSTRUCTION AND ORDERING PIPE MATERIALS, CONTRACTOR SHALL POTHOLE EXISTING UTILITIES TO VERIFY EXACT LOCATION, ALIGNMENT, DEPTH, AND SIZE. CONTACT ENGINEER IF ADJUSTMENT IS REQUIRED.

STORM DRAIN (SD) KEYED NOTES: #

- CONNECT TO EXISTING 34" CONCRETE PUBLIC STORM MAIN WITH NEW 48" MANHOLE. RIM AND INVERT ELEVATION (IE) PER PLANS.
- 48" SD MANHOLE. RIM AND IE PER PLAN.
- 24" SD MINI MANHOLE. RIM AND IE PER PLAN.
- SD BEEHIVE OVERFLOW.
- SD CLEANOUT (CO). IE PER PLAN.
- SD AREA DRAIN. RIM AND IE PER PLAN.
- ADJUST EXISTING MANHOLE RIM TO FINISHED GRADE ELEVATION.

LEGEND

EXISTING GROUND CONTOUR (1 FT)	---	149
EXISTING GROUND CONTOUR (5 FT)	---	150
FINISHED GRADE CONTOUR (1 FT)	---	149
FINISHED GRADE CONTOUR (5 FT)	---	150
PROPOSED MANHOLE (MH)	⊙	
PROPOSED CLEANOUT (CO)\DOWNSPOUT (DS)	•	
PROPOSED CATCH BASIN (CB)	■	
BEEHIVE OVERFLOW DRAIN (BH)	⊙	
MINI MANHOLE (MMH)	○	
STORMWATER FACILITY	+	
ADA RAMP LANDING AREA (2% MAX ANY DIRECTION)	▨	
TRENCH DRAIN	---	

**PRELIMINARY ONSITE GRADING AND DRAINAGE PLAN
 THE CANNERY FUND
 SALEM, OREGON**



REVISIONS: DECEMBER 31, 2024
 JOB NUMBER: 5968-01
 DATE: 01/23/2024
 DESIGNED BY: TDR
 DRAWN BY: MJM
 CHECKED BY: TDR

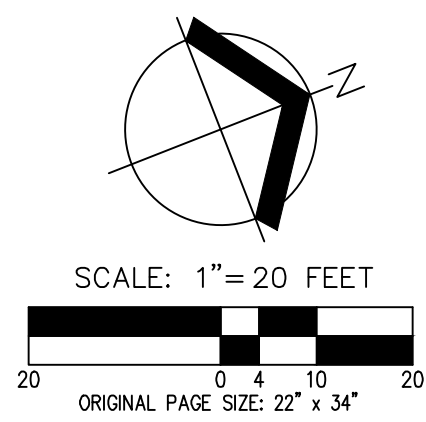

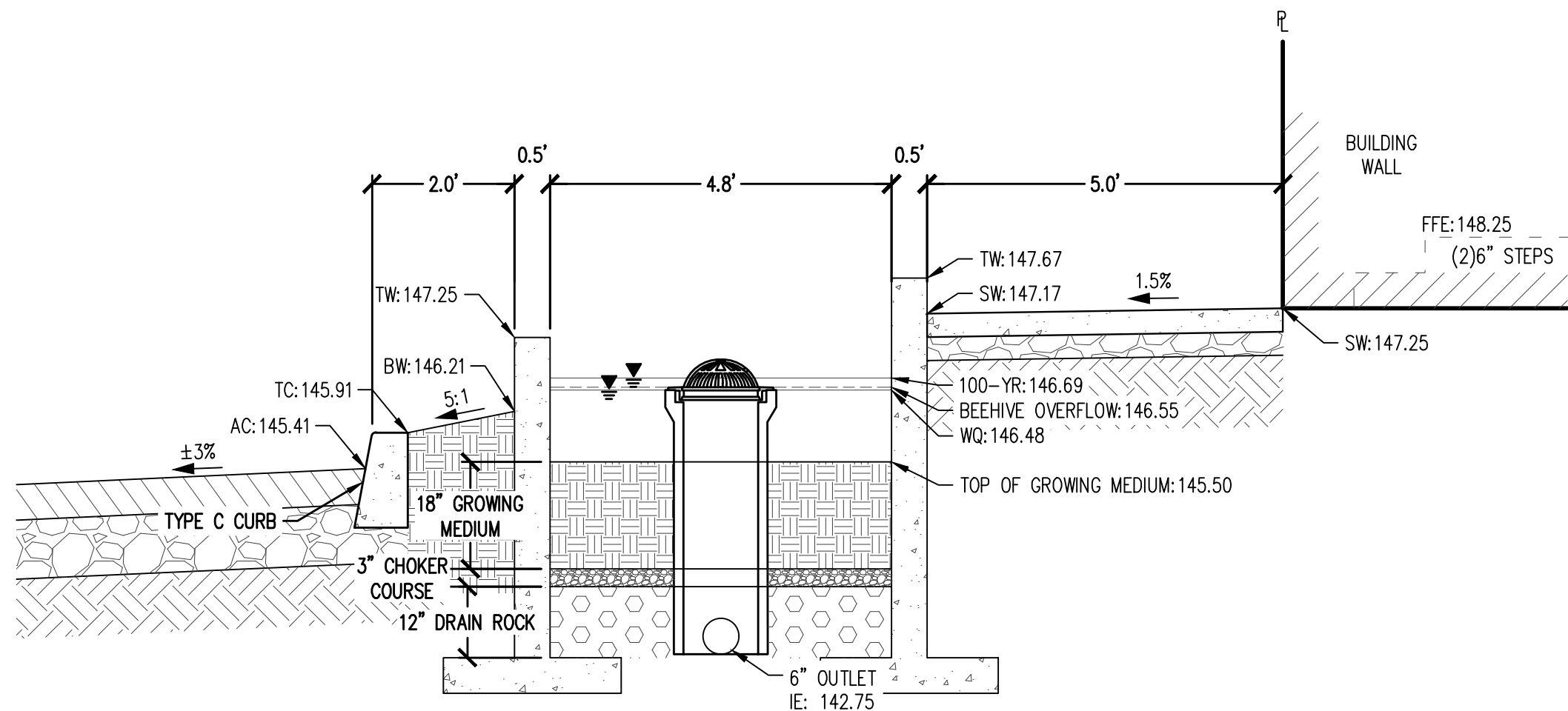

1 BUILDING 1 PLANTER CROSS-SECTION
 1" = 2"

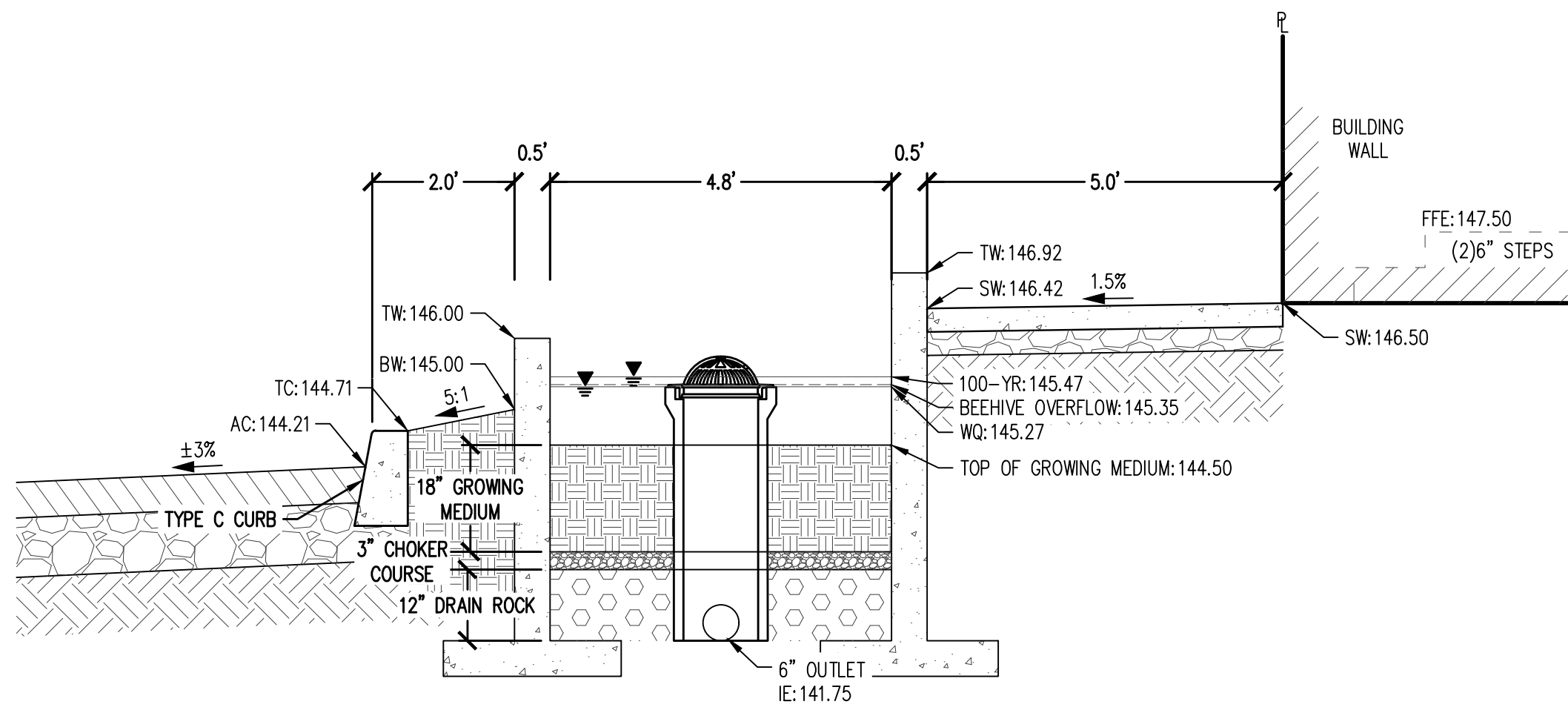

2 BUILDING 2 PLANTER CROSS-SECTION
 1" = 2"

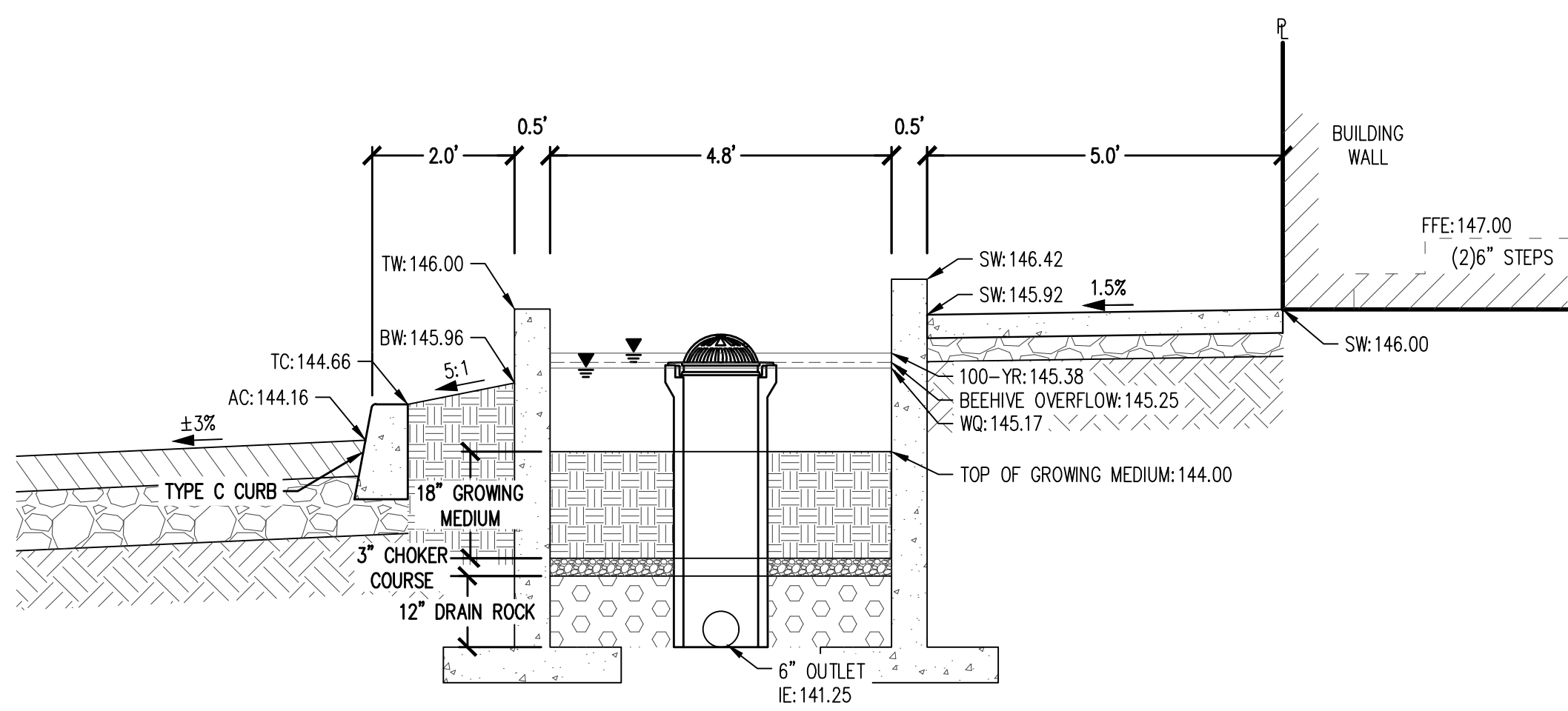

3 BUILDING 3 PLANTER CROSS-SECTION
 1" = 2"

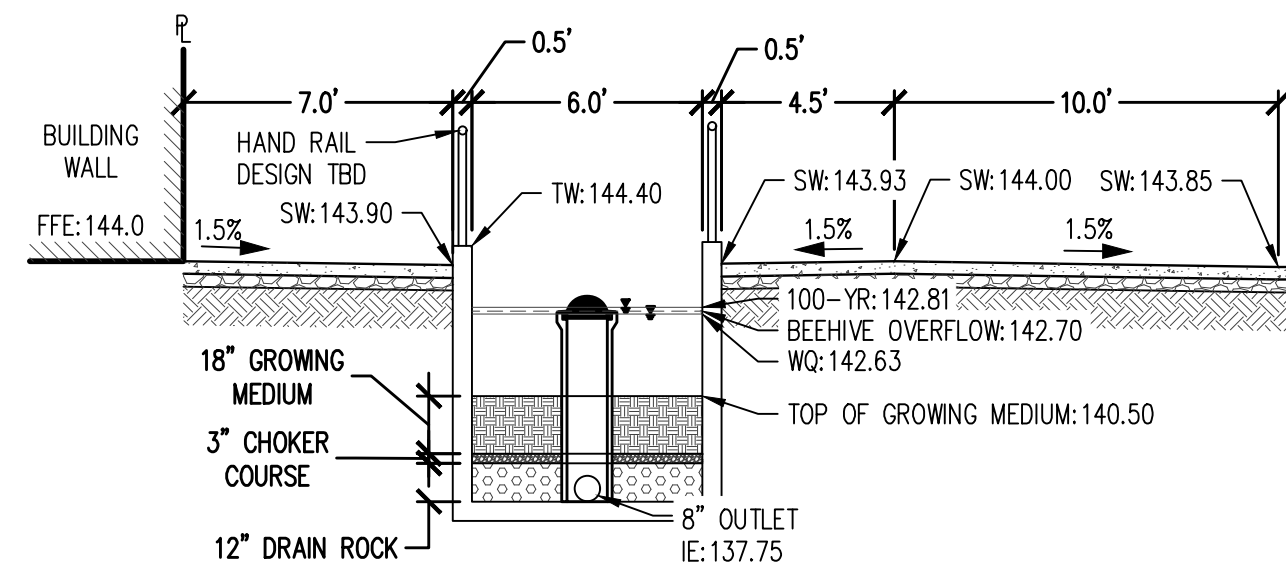

4 WINERY PLANTER CROSS-SECTION
 1" = 5"

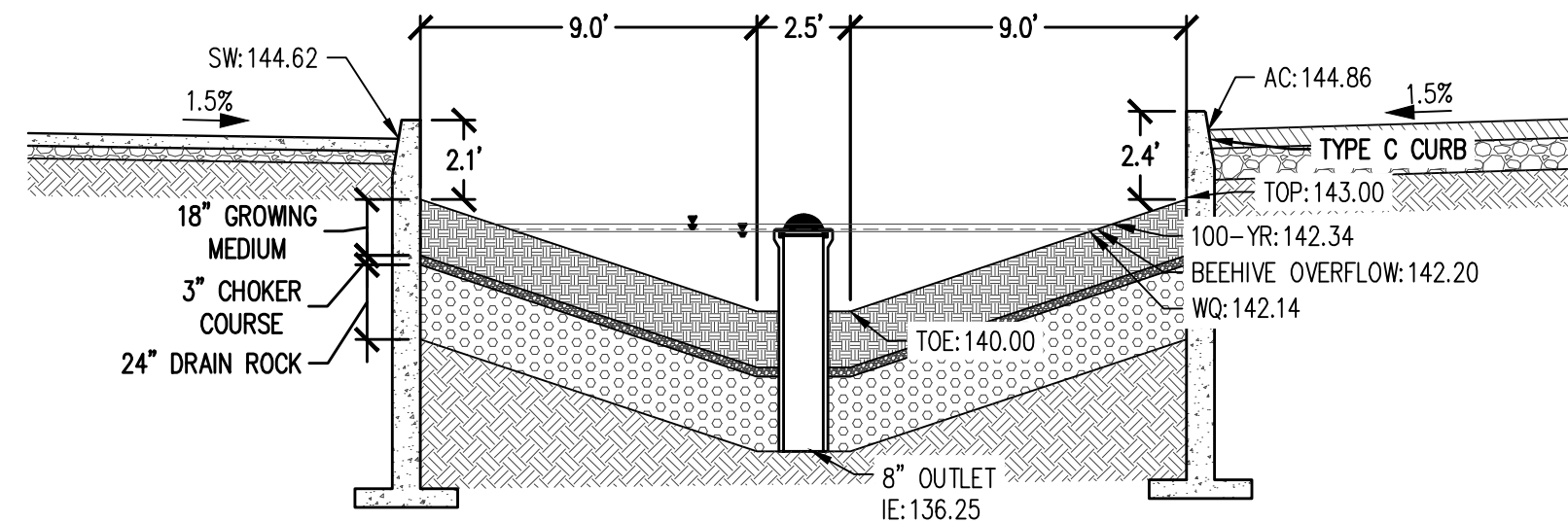

5 RAIN GARDEN CROSS-SECTION
 1" = 5"

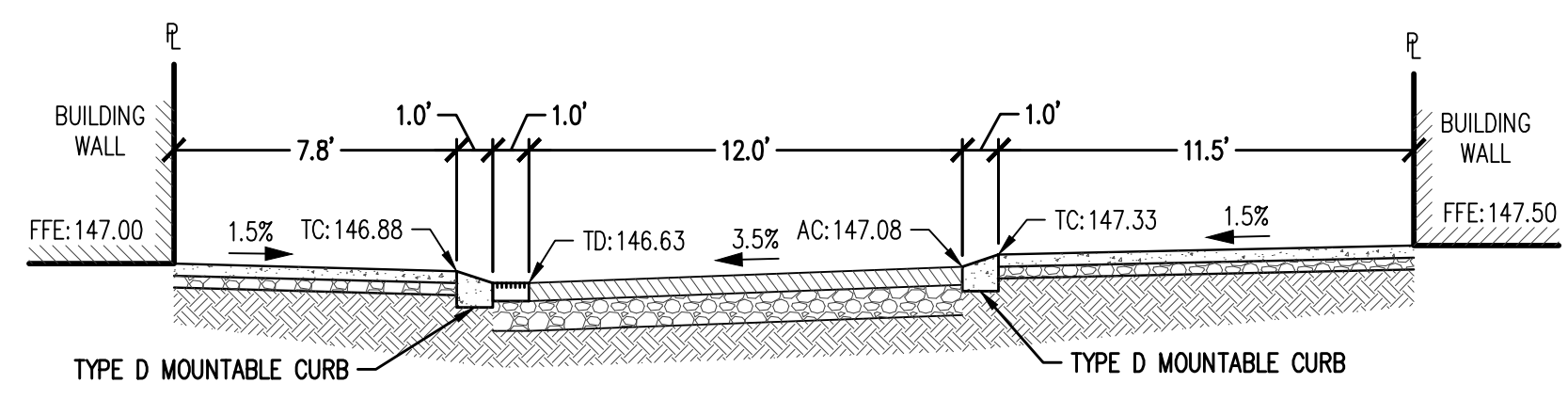

6 BELMONT ALLEY CROSS-SECTION
 1" = 5"

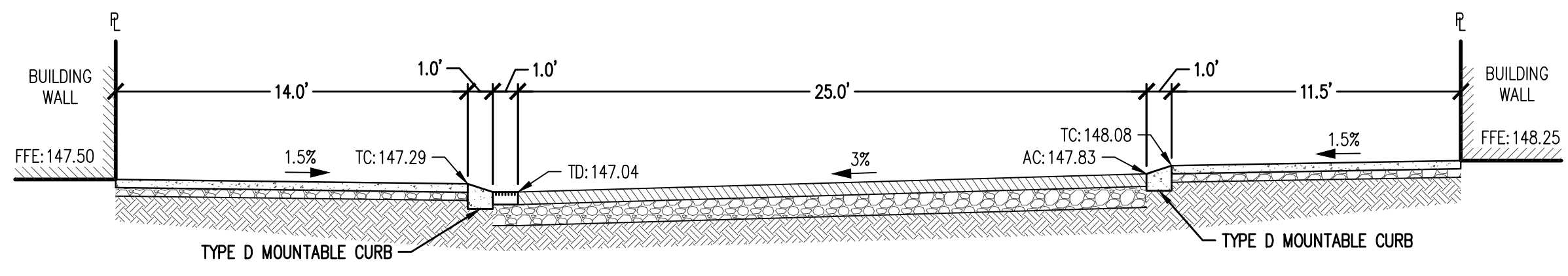

7 MARKET ST ENTRANCE CROSS-SECTION
 1" = 5"

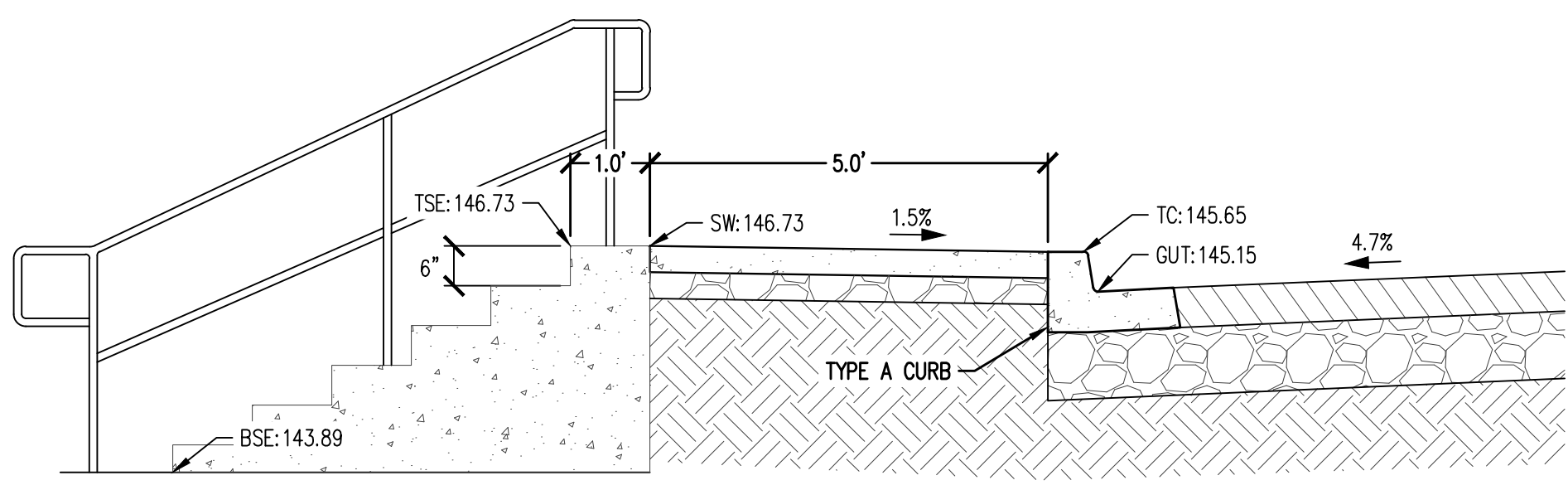

8 WINERY BUILDING STAIR STEP CONCEPT
 1" = 2"

ABBREVIATIONS:

- EXISTING:
 (RIM): EXISTING RIM ELEVATION
- PROPOSED:
 FFE: FINISHED FLOOR ELEVATION
 FG: FINISHED GRADE ELEVATION
 RIM: RIM ELEVATION
 AC: ASPHALT CONCRETE ELEVATION
 TC: TOP OF CURB ELEVATION
 BSE: BOTTOM OF STAIR ELEVATION
 TSE: TOP OF STAIR ELEVATION
 TW: TOP OF WALL ELEVATION
 BW: BOTTOM OF WALL ELEVATION
 SW: SIDEWALK ELEVATION
 TD: TRENCH DRAIN RIM ELEVATION
 GUT: GUTTER ELEVATION

DOWNWARD SLOPE: X.X%